



**PERFORM
WITH
PRECISION**

PRECAST HANDBOOK

**CONCRETE
CONSTRUCTION
PRODUCTS**

 **DAYTON[®]
SUPERIOR**



INNOVATION CENTER

REAL-WORLD SOLUTIONS INSPIRED BY YOUR VISION

Your vision is to take concrete construction to new heights. We turn that vision into real-world solutions through precision research and development, testing and technology.

Together we are redefining what is possible in the concrete construction industry. Our Innovation Center is comprised of:

- **A state of the art chemical lab**
- **A full-featured mechanical test facility**
- **Product demonstration areas**
- **Contemporary training and meeting areas**

Bring us your ideas and we will deliver your solution.

Call today: **888-977-9600**



Perform with Precision™

General and Technical Information

Safety Notes and Product Application..... 1

Safety Factors..... 1

Factors Affecting the Load-Carrying Capacity of an Insert.....2

The Mechanical Strength of the Insert.....2

The Strength of the Concrete.....3

Safe Working Load Reduction Factors for Inserts Used in Lightweight Concrete.....4

Location of Insert.....5

Insert Placement.....5

Edge and Shear Loading.....6

Torque-Tension Relationship.....7

NC Threaded Bolt Capacities.....7

Condition of Loadings.....7

Corrosion Protection.....8

ASTM Standards for Corrosion Resisting Coatings.....8

Condition of Loading.....9

Transverse and Shear Loading.....10

Calculating Sling/Anchor Loads.....11

Rigging For Traveling Over Rough Ground.....11

Rigging.....12

Selecting the Proper Insert.....13

Coil Insert Safe Working Load Reduction Factors For Free Edge Conditions – Tension Loadings Only 15

How to Use Reduction Factors:..... 15

Coil Insert Safe Working Load Reduction Factors For Thin Wall Conditions – Tension Loadings Only .. 16

How to Use Reduction Factors:..... 16

Swift Lift® System

Swift Lift® System..... 17

P50 Swift Lift® Universal Lifting Eye..... 17

P50 Inspection and Maintenance..... 17

Dos and Don'ts of the P50 Swift Lift Universal Lifting Eye..... 18

Inspection and Maintenance..... 19

How to use the P51 Swift Lift® Lifting Eye..... 21

P52 Swift Lift® Anchor..... 22

P52 Swift Lift Anchor and Recess Plug Dimensions..... 22

How to Install P56 and P56PL Recess Plugs on P52 Anchors..... 23

“Wet Setting” P52 Swift Lift Face Lift Anchors..... 23

Recess Plug Removal..... 23

Selecting the Proper Swift Lift Anchor..... 23

P52 Swift Lift® Anchor Tensile and Shear Capacity..... 24

P52W Swift Lift® Anchor..... 25

P52 Swift Lift Anchors for Edge Lifting..... 25

P59 Swift Lift® Shear Bar..... 26

P59 Swift Lift® Smooth Wire Shear Bar..... 26

P52 Swift Lift® Anchor in Thin Walls..... 27

Swift Lift® Anchor Effective Tensile Capacity in Thin Walls..... 27

Swift Lift® Anchor Effective Tensile Capacity in Thin Walls..... 28

Swift Lift® Anchor Effective Tensile Capacity in Thin Walls..... 29

Swift Lift® Anchor Effective Tensile Capacity..... 30

Swift Lift® Anchor Effective Tensile Capacity..... 31

P53 Swift Lift® Eye Anchor..... 32

P53 Swift Lift Eye Anchor for Lifting and Handling... 32

P53 Swift Lift Eye Anchor Selection Table..... 32

P60 Swift Lift® Tension Bar..... 33

P60 Swift Lift® Tension Bar Installation..... 33

P54 Swift Lift® Throw-Away Recess Plug..... 34

P56 Swift Lift® Narrow Recess Plug..... 35

P56R Swift Lift® Round Recess Plug..... 35

P56PL Swift Lift® Plus Recess Plug..... 36

P57 Swift Lift® Steel Recess Plug..... 36

P58 Swift Lift® Rubber Ring..... 36

P61 Swift Lift® Setting Plate, P62 Countersunk Screw..... 37

P63 Swift Lift® Stud, P64 Swift Lift Wing Nut..... 37

P63PL Swift Lift® Plus Holding Stud, P64PL Swift Lift Plus Wing Nut..... 37

P66 Swift Lift® Tapped Plate..... 38

P66PL Swift Lift® Plus Threaded Plate..... 38

P67PL Swift Lift® Plus Stud Plate..... 38

P68PL Swift Lift® Plus Holding Plate..... 38

P69 Swift Lift® Magnetic Setting Plate..... 38

P104 Magnetic One Piece Swift Lift® Recess..... 38

Fleet-Lift™ System

Fleet-Lift™ System Overview..... 39

P91S Fleet-Lift Ring Clutch..... 40

Installation of P91S Ring Clutch..... 40

P91NC Fleet-Lift Cable Bail Ring Clutch..... 41

Inspection and Maintenance of Ring Clutches..... 41

Additional Inspection of Cable Bails..... 41

P92 Fleet-Lift Erection Anchor..... 42

P92 Fleet-Lift Erection Anchor Tension and Shear Capacities..... 43

P92P Fleet-Lift Erection Anchor with Shear Plate..... 44

P92P Fleet-Lift Erection Anchor with Shear Plate Capacities..... 45

P92DP Fleet-Lift Erection Anchor with Shear Plate and Shear Pin..... 46

P92DP Fleet-Lift Erection Anchor with Shear Plate and Shear Pin Capacities..... 47

P92FE Fleet Lift Forged Erection Anchor..... 48

P92FEW Fleet Lift Forged Erection Anchor with Sheer Plate..... 49

P92FEWDP Forged Erection Anchor with Shear Plate and Secondary Shear Pin..... 50

P92H Fleet-Lift Two-Hole Erection Anchor..... 51

P92HP Fleet-Lift Two-Hole Erection Anchor with Shear Plate..... 51

Shear Reinforcement..... 51

Tension Reinforcement..... 51

P92H Fleet-Lift Two-Hole Erection Anchor and P92HP Fleet-Lift Two-Hole Erection Anchor with Shear Plate Capacities..... 52

P92FEH Fleet-Lift Forged Erection Anchor..... 53

P92S Fleet-Lift Sandwich Panel Erection Anchor 54

P92SP Fleet-Lift Sandwich Panel Erection Anchor with Shear Plate..... 54

P92SF Fleet-Lift Sandwich Panel Erection Anchor..... 55

P92T Fleet-Lift Sandwich Panel Reinforcing Bars 56

P92AH Fleet-Lift Erection Anchor with 45° Head with Shear Plate.....57

P93 Fleet-Lift L-Anchor..... 58

P94 Fleet-Lift T-Anchor..... 58

P94H Fleet-Lift H-Anchor 2-Ton..... 59

P94S Fleet-Lift S-Anchor..... 60

P95F Fleet-Lift Flat Foot Anchor..... 60

P95P Fleet-Lift Plate Anchor..... 61

P96 Fleet-Lift Two-Hole Anchor..... 61

T110 Superior Lift System..... 62

P98S Fleet-Lift Shear Bar..... 63

P98T Fleet-Lift Tension Bar..... 63

P99 Fleet-Lift Reusable Recess Plug..... 64

P100 Fleet-Lift Holding Plate and P101 Fleet-Lift Holding Rod..... 64

Installation and Removal of Anchors and Reusable Recess Plugs..... 65

P99C Fleet-Lift Cast Steel Recess Plug..... 66

Installation and Removal of the Fleet-Lift Cast Steel Recess Plug..... 67

P99D Fleet-Lift Disposable Recess Plug (PVC)..... 68

Installation of P99D Disposable Recess Plug and Erection Anchors..... 69

Installation of P99D Disposable Recess Plug and Standard Anchors..... 70

P99D Temporary Cover/Patch Installation..... 71

P99P Fleet Patch..... 72

P100M Fleet-Lift Magnetic Plate..... 73

P100MS Setting Screw..... 73

P100M Fleet-Lift Magnetic Plate Installation..... 73

P104 Fleet Lift One Piece Magnetic Recess..... 73

Utility Anchor®

Utility Anchor System..... 75

Anchor Placement..... 75

P72 Block Wall Lifting Anchor..... 76

P73SL Thin Slab Utility Anchor..... 77

P75 and P75H Utility Anchor®..... 78

P75C Utility Anchor® with Clip..... 78

P76 Utility Anchor® Setting Plugs..... 79

P76D Disposable Setting Plugs..... 79

P76C Utility Anchor Cover/Patch..... 79

P76M Utility Anchor® Magnetic Setting Plate..... 80

P100 Utility Anchor® Holding Plate..... 80

P101 Utility Anchor® Holding Rod..... 80

P104 One Piece Magnetic Utility Anchor® Recess Anchor Placement..... 81

P76 Utility Anchor® and Double Tee Anchor Setting Plug..... 81

P110 Wire Rope Lifting System™..... 82

General and Technical Information

Swift Lift System

Fleet-Lift System

Utility Anchor Lifting System

Lifting/Handling Inserts and Accessories

Structural Connectors

Miscellaneous Connection Inserts

Sandwich Panel Connectors

Miscellaneous Products

- General and Technical Information
- Swift Lift System
- Fleet-Lift System
- Utility Anchor Lifting System
- Lifting/Handling Inserts and Accessories
- Structural Connectors
- Miscellaneous Connection Inserts
- Sandwich Panel Connectors
- Miscellaneous Products

Lifting and Handling Inserts

B1 or B2 Coil Ties Used as Inserts	83
Mounting Washers.....	83
B11 Flat Washer.....	84
B12 Coil Rod.....	84
B13 Coil Nut and B25 Heavy Coil Nut.....	84
B14 Coil Bolt.....	85
B16 Straight Coil Loop Insert.....	86
B17 Double Flared Coil Loop Insert	86
B18 Single Flared Coil Loop Insert.....	87
B33 Double Flared Coil Loop Insert.....	88
F47 Double Flared Loop Insert.....	88
F48 Eye Nut, F49 Eye Bolt and F49A Eye Bolt.....	89
P21 Wire Rope Loop.....	90
F53 Thin Slab Coil Insert.....	90
F56, F58 and F60 Expanded Coil Inserts.....	91
F63 Flared Thin Slab Coil Insert.....	92
F65 Type L Coil Insert.....	92
T1 Single Pickup Insert	93
P1 Single Pickup Insert	93
T3 and T3A End Pickup Inserts	94
T7S and T7ST Slotted Setting Studs.....	95
P25 Plastic Setting Bolt.....	95
T8 Lifting Angle.....	95
T10 and T11 End Pickup Inserts	96
Proper Installation of T3 and T11 End Pickup Inserts.....	97
How To Determine Bolt Length.....	97
T12 Swivel Lifting Plate	98
T21 Insert Locator Plugs	98
T26 Double Swivel Lifting Plate.....	98
T27 Edge Lifting Plate.....	99
Dos and Don'ts.....	99
Total System and Safe Working Loads.....	99

NC Threaded Inserts

F5 Threaded Insert.....	101
F42 Loop Ferrule Insert	101
F43 Plain Ferrule.....	102
Special Ferrule Application	102
F44 Thin Slab Ferrule Insert	103
F45 Cap Plug	103
F50 Rocket/Kohler® Ferrule Insert.....	104
F52 Thin Slab Ferrule Insert	104
F54 Ductile Embed Insert	105
F57 Expanded Coil Ferrule Insert	106
F59 Expanded Coil Ferrule Insert	106
F61 Expanded Coil Ferrule Insert.....	106
F62 Flared Thin Slab Ferrule Insert	107
F64 Ferrule Loop Insert	108
F72 Threaded Setting Plug	109
F74 Threaded Plastic Plug.....	109
P90 Connecting Systems Nylon Threaded Inserts.....	110
D108A Headed Dowel Bar Insert.....	111

Sleeve-Lock® Grout Sleeve

D410 Sleeve-Lock® Grout Sleeve.....	113
D490 Sleeve-Lock® Grout	113
D487 Sleeve-Lock® Seal Plug.....	114
D491 Sleeve-Lock® Form Plug.....	114
D492 Sleeve-Lock® 3/4" SCH40 PVC.....	114
D493 Sleeve-Lock® Port Plug.....	114

Threaded Splicing Systems

Dowel Bar Splicer System*	115
---------------------------------	-----

Bar Lock® Rebar Coupler System

Dayton Superior Bar Lock® Coupler System*	116
F Other Connection Inserts	
11 Hanger Insert and F12 Hanger Hook	117
P30 Corewall® Nut Type Slotted Insert.....	117
P31 Corewall® Strap Type Slotted Insert	117
P30 Corewall® Nut Type Slotted Insert.....	118
P31 Corewall® Strap Type Slotted Insert	119
P32 Corewall® Strap Anchor.....	119
P33 Corewall® Slotted Strap Anchor	119
P34 Corewall® Threaded Strap Anchor	119
P38 Corewall® Slotted Insert II.....	120
P12D Dur-O-Web® Shear Reinforcement.....	124
P12D Dur-O-Web® Shear Reinforcement.....	125

Sandwich Panel Connectors

P24 Delta Tie	127
P24 Delta Tie	128
P24 Delta Tie Design Table.....	129
P24 Delta Tie Insulated Panel Installation Sequence. 130	
P24XL Delta Tie.....	131
P12G Welded Wire Girders.....	132
P9 Precast Sandwich Panel Tie.....	133
P37 "M" Anchor Shear Connector.....	133

Strand Restraining Devices

Prestress Strand Restraining Devices.....	135
---	-----

Precast Bracing

T14 Precast Wall Braces.....	136
T15 Pipe Brace Extensions	136
Brace Length and Safe Working Loads.....	137
Brace Length and Ultimate Loads	137
Brace Loading.....	138
Bracing to Cylindrical Deadman.....	139
Brace Maintenance.....	139
Accubrace® Total Bracing System.....	140
Accubrace Components	141
Accubrace Components	142

Formliners

Formliners	143
Vinyltite™ Trapezoidal Interlocking Formliners	143
Thermoform™ Vacuum-Formed Formliners.....	143

Chemicals

Dayton Superior Chemicals Dedicated Support ...	146
---	-----

Other Products

Rustications, Chamfers and Covers.....	147
PLW – EZ Lok Wheel™	148
PSW – Space Wheel™	148
Tower Bar Chair.....	149
Tower High Chair.....	149
E-Z Chair®	149
Castle Chair™	149
X-Chair	150
E-Z Lok™ Slab Bolster	150
PSBU Strongback SBU™	150
Panel Pads.....	150
Slab Bolster	151
Beam Bolster.....	151
Continuous High Chair.....	151
Individual High Chair	151
Bar Chair.....	151
Joist Chair.....	151
K50 Void Retention Insert.....	152
H13 Round Void Hold Down.....	152
P80 Shim Strips.....	153
P81 Shimpak.....	153
P82 Bearing Strips.....	154
P83 Horseshoe Spacers	154
P84 Korolath Core Plugs.....	154
F67, F68, and F69 Ceiling Hangers	155
F75 Marble Facing Anchor.....	155
Cushion-Lock® Reglet Type B4	156
Connector Plugs	156
Insulation Fixings.....	157
T68 ACA 1000® Construction Spray Adhesive	157

Magnets

P153 Magnetic Steel Chamfer and Reveal.....	158
P154 On/Off Magnets, Cam Magnets, Button, Loaf Magnets and Accessories	158

Index.....161

Safety Notes and Product Application

In the continuous development of hardware for the precast industry, Dayton Superior places great emphasis on ensuring that material supplied from its manufacturing plants meets or exceeds safety requirements for lifting, handling and connecting precast concrete elements. Dayton Superior and/or independent testing laboratories have conducted tests on products shown in this handbook. The safe working loads listed were determined from these tests and were established with the following factors in mind:

1. All safe working loads shown are based on the item being new or in "as new" condition.
2. No loads greater than the product's safe working load.
3. All inserts properly embedded and firmly fixed in place in sound, normal weight concrete so that the vertical axis of the insert is perpendicular to the lifting surface.
4. All bolted hardware has full bearing on the concrete surface and all attachment bolts bear fully on the hardware. Do not subject hardware to side loading that will cause additional and unintended loading.
5. Erection and attachment bolts are of proper length and are well tightened to prevent hardware slippage and bolt bending.
6. Coil bolts have at least the specified minimum penetration through the insert coil, but do not bear on concrete at the bottom of the void.
7. Concrete compressive strength (f'c) at time of initial use is at least the strength listed in the appropriate insert selection chart.
8. Inserts are properly located in relation to edges, corners and openings and at a proper distance to permit the development of a full concrete shear cone. Refer to the minimum edge distances shown in the appropriate insert selection chart.
9. Tensile load on the insert has been calculated, including the effect of both axial and transverse loads, as transmitted by the crane lines to the hardware.
10. No impact wrenches will be used to tighten bolts used for lifting, handling, transporting, connecting or bracing.
11. All zinc plated medium-high carbon, or high carbon steel items have been properly baked to relieve embrittlement. Not doing so may result in premature failure.
12. There has been no welding on any portion of an insert or to lifting hardware units after they have left a Dayton Superior manufacturing plant. Welding may cause embrittlement, which can result in a premature failure. Welding requires a good working knowledge of materials, heat treatment and welding procedures. Since Dayton Superior cannot control field conditions or workmanship, Dayton Superior DOES NOT GUARANTEE any product altered in any way after leaving the factory.

Safety Factors

A safety factor applied to a particular product is a variable, depending on the degree of hazard or risk involved in the application of that product. In precast concrete construction various conditions can often increase loading, as well as the degree of risk involved. Adhesion of the concrete element to the form, jerking of the crane during lifting, use of a crane not adequate for the job, bouncing the precast element after it has been lifted, handling the element more than anticipated, transporting over rough surfaces, etc., all have high risk factors. In cases such as these, the user should increase the safety factor accordingly.

Dayton Superior recommends that the following minimum safety factors be used when determining a product's safe working load and that the provisions of OSHA (Occupational Safety and Health Administration Act, Part 1910) be strictly followed when considering safety factors:

If a different safety factor from one shown in this handbook is required for any reason, the following equation is used to increase or reduce a safe working load:

Safety Factor	Intended Use of Product
2 to 1	Brace Anchors
3 to 1	Permanent Connections
4 to 1	Inserts used for lifting and handling
5 to 1	Hardware used for lifting and handling

$$\text{New Safe Working Load} = \frac{\text{Old Safe Working Load} \times \text{Old Safety Factor}}{\text{New Safety Factor}}$$

Warning: New safe working load must not exceed the product's mechanical capacity divided by the new safety factor.

USERS OF DAYTON SUPERIOR PRODUCTS MUST EVALUATE THE PRODUCT APPLICATION, CALCULATE INDUCED LOADS, DETERMINE NECESSARY SAFETY FACTORS, CALCULATE SAFE WORKING LOADS AND CONTROL ALL FIELD CONDITIONS TO PREVENT APPLICATION OF LOADS IN EXCESS OF THE SAFE WORKING LOAD.

Factors Affecting the Load-Carrying Capacity of an Insert

Attachment Bolt and Hardware Considerations:

The selection of an attachment bolt diameter will depend upon the job the bolt is required to do. If, for instance, bolts are to be used repeatedly and are subject to tension and shear, choose a bolt at least one size larger in diameter than static loading conditions would require. Since coil bolts are not intended for bending loads, care must be taken to be sure that the bolts are properly tightened.

Bolt failures are generally caused by excessive thread wear, field modification, or bending and/or straightening of bolts. It is the responsibility of the user to continually inspect bolts and working hardware for wear and discard the parts when wear is noted. Do not straighten bent bolts, discard and replace them. Also, any bolts known to have been used at loads of 70%, or more, of ultimate strength should be removed from service and discarded. Such bolts may have been stretched sufficiently to become brittle-hard and could lead to premature failure of the bolts. Every user must establish a control program to replace attachment bolts after a predetermined number of uses, regardless of their appearance.

Lifting hardware shown in this handbook is subject to wear, misuse, overloading, corrosion, deformation, intentional alteration and other factors that could affect the hardware's safe working load. Therefore, the user must inspect the condition of the hardware units regularly to determine if they can be used at their rated safe working load. If not, they must be removed from service. The frequency of inspection is best determined by the user and is dependent upon factors such as frequency of use, period of use and environmental conditions.

The Mechanical Strength of the Insert

Lifting inserts/anchors displayed in this handbook are fabricated from carbon steel that has sufficient strength to safely carry the specified safe working loads. Many of the inserts/anchors herein can be special ordered, fabricated from stainless steel material. When an insert is fabricated from stainless steel, it may have a lower safe working load than the safe working load published for the corresponding carbon steel insert. Contact a Dayton Superior Technical Services Department for safe working loads of inserts fabricated from stainless steel.

Wire and Rod Sizes and Strengths

Unless otherwise noted, inserts and anchors shown on the following pages will have anchor legs made of material having characteristics listed below.

Wire and Rod (Nominal) Size	Wire Classification	AISI or ASTM Grade (Reference)	Approximate Minimum Ultimate Strength	Approximate Minimum Yield Strength	Approximate Minimum Shear Strength
.218" 5.5 mm	Low Carbon	1006 or 1008	2,800 lbs. 12.5 kN	2,400 lbs. 10.7 kN	1,850 lbs. 8.2 kN
.223" 5.7 mm	Medium High Carbon	1030	4,500 lbs. 20.0 kN	3,800 lbs. 16.9 kN	3,000 lbs. 13.3 kN
.240" 6.1 mm	Low Carbon	1006 or 1008	3,100 lbs. 13.8 kN	2,500 lbs. 11.1 kN	2,050 lbs. 9.1 kN
.243" 6.2 mm	Medium High Carbon	1038	7,000 lbs. 31.1 kN	6,000 lbs. 26.7 kN	4,650 lbs. 20.7 kN
.262" 6.7 mm	Low Carbon	1006 or 1008	4,100 lbs. 18.2 kN	3,200 lbs. 14.3 kN	2,750 lbs. 12.2 kN
.306" 7.8 mm	Low Carbon	1006 or 1008	4,200 lbs. 18.7 kN	3,300 lbs. 14.7 kN	2,800 lbs. 12.5 kN
.306" 7.8 mm	Medium High Carbon	1038	7,400 lbs. 32.9 kN	6,500 lbs. 28.9 kN	4,950 lbs. 22.0 kN
.375" 9.5 mm	Medium Low Carbon	1018	9,500 lbs. 42.3 kN	7,300 lbs. 32.5 kN	6,350 lbs. 28.2 kN
.440" 11.2 mm	Medium High Carbon	1035 or 1038	16,000 lbs. 71.2 kN	13,500 lbs. 60.0 kN	10,650 lbs. 47.4 kN
.375" 9.5 mm	Swift Lift Anchor	1018	8,300 lbs. 36.9 kN	7,050 lbs. 31.4 kN	5,550 lbs. 24.7 kN
.562" 14.3 mm	Swift Lift Anchor	1018	18,600 lbs. 82.7 kN	15,800 lbs. 70.3 kN	12,400 lbs. 55.2 kN
.750" 19.1 mm	Swift Lift Anchor	1018	33,100 lbs. 147.2 kN	28,100 lbs. 125.0 kN	22,050 lbs. 98.1 kN
1.094" 27.8 mm	Swift Lift Anchor	1018	65,800 lbs. 292.7 kN	55,900 lbs. 248.6 kN	43,850 lbs. 195.0 kN
1.500" 38.1 mm	Swift Lift Anchor	1018 Equivalent	132,300 lbs. 588.5 kN	112,400 lbs. 500.0 kN	88,200 lbs. 392.3 kN

NOTE. Wire sizes listed above conform to ASTM Standard A-510 Specification for General Requirements for Wire Rods and Coarse Round Wire, Carbon Steel. The rod sizes listed conform to ASTM A-108 Specification for Steel Bars, Cold Finished, Standard Quality.

The Strength of the Concrete

When a load is applied to an insert embedded in concrete, it induces a corresponding resistive force in the concrete. Insert failures can be predicted with a reasonable degree of accuracy by using the following equation for concrete breakout from ACI 318 Appendix D.

f'_c = Compressive strength of the concrete at time of lift

$$\text{Tension Safe Working Load} = \frac{\phi_{c,N} \times \lambda \times 24 \times \sqrt{f'_c} \times h_{ef}^{1.5}}{\text{Appropriate Safety Factor}}$$

λ = Reduction factor for use with lightweight concrete, see "Safe Working Load Reduction Factors for Inserts Used in Lightweight Concrete" next page;

$\phi_{c,N}$ = Factor for cracked concrete: 1.0 if cracked and 1.25 if uncracked.

When the value of $P_{concrete}$ exceeds the ultimate mechanical tensile capacity of the insert, the insert will fail. It is apparent that the shear

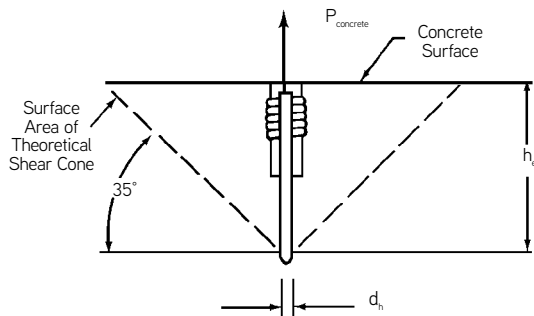

Illustration A1

For inserts located near an edge preventing development of a full shear cone please contact a Dayton Superior Technical Services Department for insert capabilities.

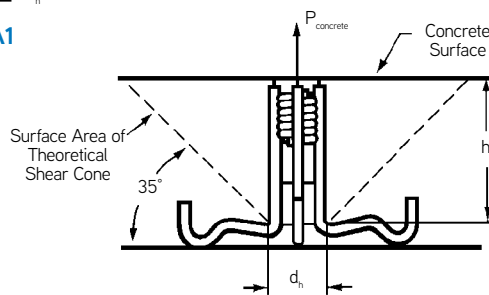

Illustration A2

Warning! Adding rebar to the horizontal portion of an insert will reduce the depth of the shear cone (l_e), resulting in a reduced insert capacity. When rebar are added for insert stability, they should be placed against the vertical portion of the insert and at least 1" away from the horizontal portion.

cone becomes larger as the insert is embedded deeper in the concrete. Sufficient depth of embedment would theoretically permit the development of the full ultimate strength of the insert.

Deep embedment is generally considered impractical for precast concrete, but some types of anchors depend upon this principle for their effectiveness. The Dayton Superior F1 Screw Anchor and P52 Swift Lift Anchor are two examples.

All other factors being equal, depth of embedment has more effect on the strength of a concrete insert than any other single factor. A concrete insert under tensile loading to failure will fail in one of four ways:

1. The entire insert may pull out of the concrete with little apparent damage to the concrete (see Illustration B). Such failures are rare and, when they do occur, are the result of bond failure between the concrete and insert. These failures usually occur in "green" and/or low strength concrete.
2. The entire insert may pull out of the concrete bringing with it a cone of concrete having its apex slightly above the most deeply embedded part of the insert (see Illustration C). Such failures usually occur in relatively low strength concrete in which the tensile strength of the "shear cone" surrounding the insert is not as great as the strength of the insert itself.
3. A failure may also occur through breakage of the insert. Coil type inserts will usually fail at a point just below the helically wound wire coil. A small cone of concrete will usually be pulled out of the concrete surface (see Illustration D). This cone will have its apex at a point just below the coil. The base diameter will be approximately twice the cone height. Swift Lift Inserts will fail by fracturing of the shaft diameter of the insert (see Illustration E).

NOTE: The above formulas have been applied to all coil and ferrule insert charts in this handbook. All manufactured lifting systems (Swift Lift, Fleet Lift, Utility Anchor) utilize test results. These failures occur in high strength concrete when an insert is loaded beyond the ultimate strength of the insert. Failures of this type are due to a definite overload being applied to the inserts. Such failures can be prevented by choosing inserts of capacity suitable to job conditions.

4. When bolting coil type inserts, the bolt should always extend the proper amount beyond the bottom of the insert coil. Failure to do this causes the entire bolt load to be transferred to fewer turns of the coil, causing an increased load per weld contact point. The coil will then unwind, much like a corkscrew, resulting in a failure (see Illustration F).

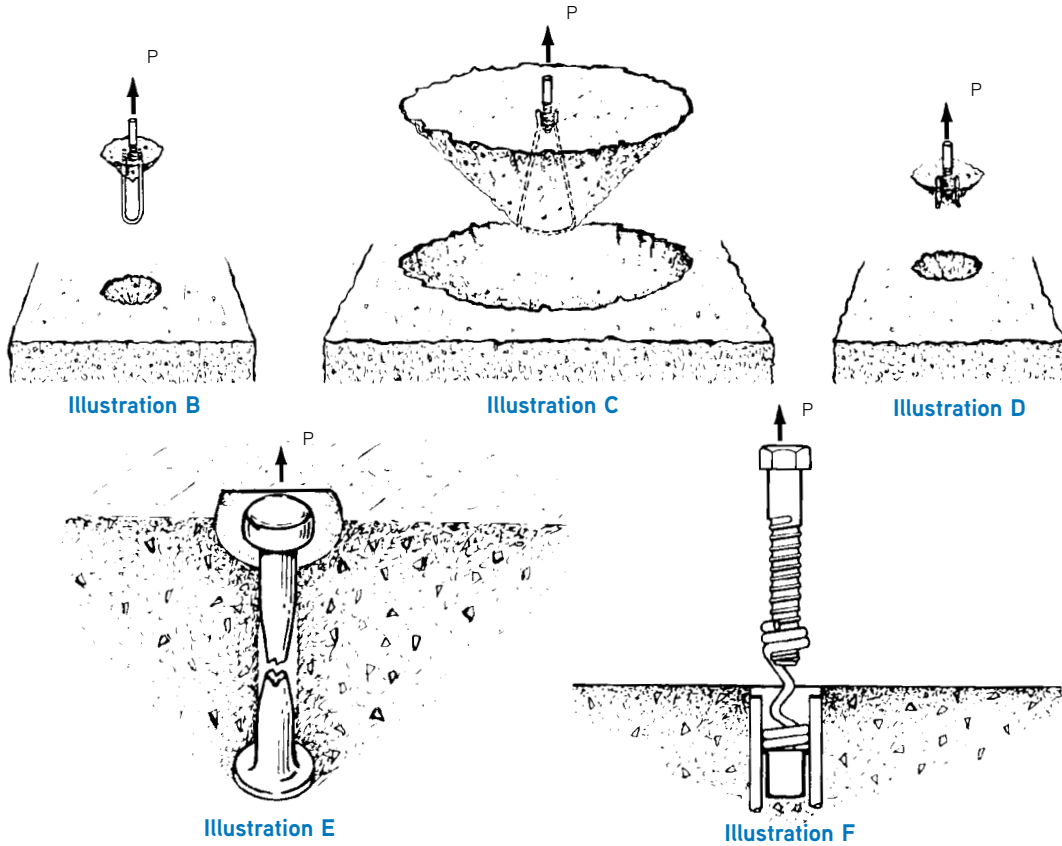

Safe Working Load Reduction Factors for Inserts Used in Lightweight Concrete

Insert safe working loads, shown in this handbook, were derived from analysis and testing of Dayton Superior inserts used in normal weight (150 pcf) concrete. The safe working load of the insert is dependent upon the compressive strength of the concrete in which it is embedded. Therefore, when Dayton Superior inserts are used in lightweight concrete precast elements, the safe working load of the inserts must be recalculated to compensate for the reduction in concrete density. Multiply the published safe working loads by a reduction factor, shown in the table, to obtain the corrected safe working load. The table displays the various reduction factors recommended by Dayton Superior for lightweight concrete.

Concrete Type	Safe Working Load Reduction Factor
Normal Weight	1.0
Sand and Lightweight Aggregates	0.85
All Lightweight Materials with a Weight of 110 PCF or more	0.75
All Lightweight Materials with a Weight of 110 PCF or less	Verify by Testing

Interested readers are referred to Section 11.2 of the American Concrete Institute's "Building Code Requirements for Reinforced Concrete" (ACI 318) for additional information.

Location of Insert

Embedment of inserts closer to an edge than the minimum edge distances, shown in this handbook, will greatly reduce the effective area of the resisting concrete shear cone and will reduce the insert's tension safe working load. The shaded area of the shear cone, shown in the illustrations below, indicates the extent the shear cone area is reduced. Tension safe working loads of inserts used in thin wall conditions or near a free edge or corner must, therefore, be reduced in proportion to the reduction in effective shear cone area (see Illustrations G & H).

Another condition frequently encountered is that of an insert embedded near a free edge or corner and loaded in a transverse direction to the axis of the bolt, toward the free edge of the concrete. Contact Dayton Superior Technical Assistance for safe working loads of inserts used in this type of condition.

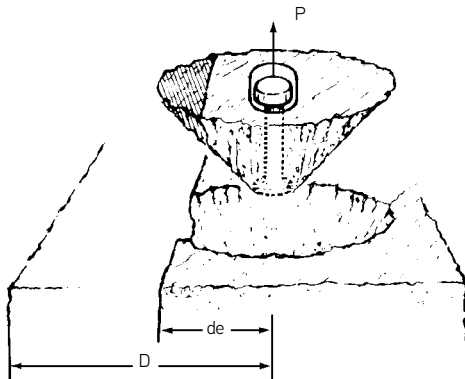

Illustration G

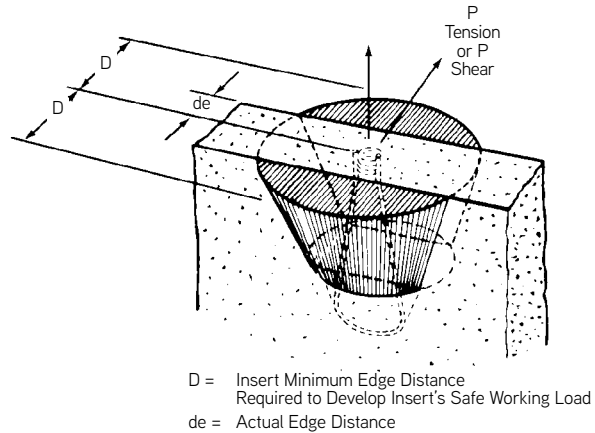

Illustration H

Insert Placement

Inserts must be placed accurately. An insert's safe working load decreases sharply if it is not perpendicular to the bearing surface, or if it is not in line with the applied force.

Inserts lend themselves to being located and held correctly (by bolts and brackets or by tying to the reinforcing steel) before the casting operation begins. Failure to achieve proper insert placement is careless field installation. It is also important to place inserts so that the depth of thread is constant for the same size insert throughout a job. This eliminates potential bolt engagement mistakes by the erection crew. Inserts should always be kept clean of dirt, ice or other objects that will interfere with attachment of the lifting hardware.

Note: For ferrule inserts, establish this dimension and maintain for all similar sized inserts on a project. For coil inserts, the coil bolt must penetrate through the insert coil by the proper amount.

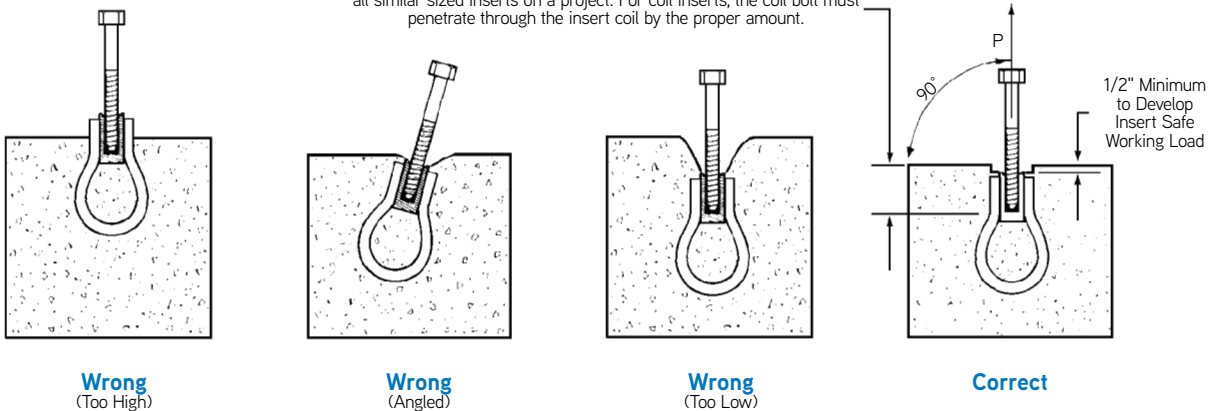

Illustration I

Edge and Shear Loading

Another condition frequently encountered is an insert embedded near a free edge or corner and loaded in a direction transverse to the axis of the bolt, toward the free edge. Edge lift panels are examples of this condition.

Many tests have shown that edge inserts loaded transversely to destruction (see Illustration L) finally fail because of an initial failure of the concrete over the coil. This initial failure transfers the entire load to the insert struts. If the load is large enough, the struts will fail in bending or shear or both.

An analysis of tests indicates that the ultimate load on edge inserts loaded in the direction of the free edge is a function of the distance from the insert to the free edge. The effect of bolt diameter and insert configuration appears to be of secondary and negligible importance. For conditions where shear loading must be considered, it is appropriate to use the following equation from ACI 318 Appendix D:

$$\text{Shear Safe Working Load (lbs.)} = \frac{\psi_c \cdot \lambda \cdot 7 \left(\frac{l_e}{n \cdot d_o} \right)^{0.2} \cdot \sqrt{n \cdot d_o} \cdot \sqrt{f'_c} \cdot (c_{al})^{1.5}}{\text{Appropriate Safety Factor}}$$

With the maximum shear safe working load equal to, or less than, the insert's tension Safe Working Load.

Where:

- ϕ_c = Cracked concrete factor: 1.0 for cracked concrete and 1.4 if uncracked.
- λ = Reduction factor for lightweight concrete, Safe Working Load Reduction Factors for Inserts Used in Lightweight Concrete" section.
- l_e = Minimum of embedment length or $8 \times (n \times d_o)$.
- n = Number of struts on the insert.
- d_o = Diameter of the insert struts.
- f'_c = Specified concrete compressive strength.
- c_{a1} = Distance from centerline of the insert to the edge.

For conditions where a corner or thickness in direction of embedment is less than $1.5 \times c_{a1}$ or an adjacent insert is closer than $3 \times c_{a1}$ contact Dayton Superior Technical Services Department for insert capacities.

For cases where increased shear capacity is required, the addition of pre-formed shear bars over the top of the insert will greatly increase the distribution of the load. Shear bars, when used, must be in solid contact with the insert to be effective.

If accurate capacities of inserts are desired, several inserts with shear bars should be tested in job size panels.

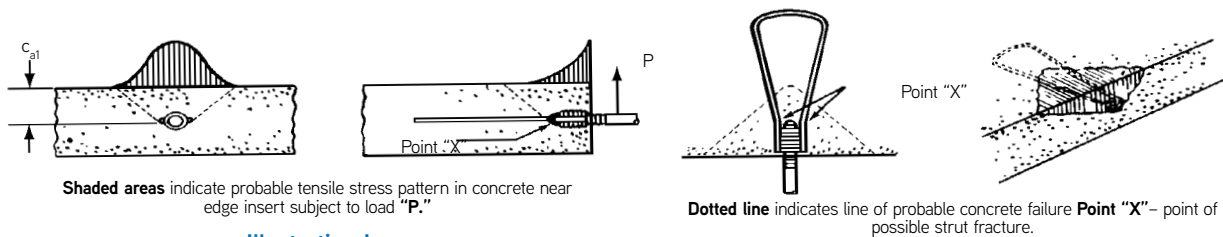

Illustration L

Combined Shear and Tension

Inserts and bolts that are subjected to combined shear and tension loadings should satisfy the following equation:

$$\left(\frac{f_v}{F_v} \right)^{5/3} + \left(\frac{f_t}{F_t} \right)^{5/3} \leq 1.0$$

Where:

- f_v = Applied shear load;
- F_v = Shear safe working load;
- f_t = Applied tension load;
- F_t = Tension safe working load.

Torque-Tension Relationship

For some types of bolted connections, it may be desirable to have a minimum clamping force (tension load). Due to the many variables associated with tightening bolted connections, it is possible to experience as much as a $\pm 25\%$ variation in the amount of clamping force applied to similar connections receiving identical torque.

The following equation is taken from "Fasteners Standards – Sixth Edition," published by Industrial Fasteners Institute, East Ohio Building, 1717 East 9th Street, Suite 1105, Cleveland, Ohio 44114-2879. It is used to provide an "estimate" of the torque required to apply a given preload to a bolted connection.

$$T = \frac{KDP}{12}$$

Where: T = Torque (ft. lbs.);
 K = Torque coefficient;
 D = Nominal bolt diameter;
 P = Tension in bolt (lbs.)

The torque coefficient is the critical factor in the above formula. It is best to experimentally determine K for critical applications using actual connection materials and assembly tools.

Arbitrary values for K are often assigned in non-critical applications, as follows:

- K = .20 for NC threaded bolts per "Fasteners Standards – Sixth Edition"
- K = .30 for Coil threaded bolts per test results.

The torque coefficient will vary from the values, shown above, when bolts have been plated, greased or coated with other types of lubricant.

NC Threaded Bolt Capacities

Permanent connections in precast construction are normally made with either ferrule inserts or slotted inserts using National Course (NC) threaded bolts. NC threaded bolts are normally not supplied by Dayton Superior. However, as a convenience to the precast designer, the following chart is listed.

NC Threaded Bolt Selection Table

Nominal Bolt Diameter and Threads per Inch	ASTM A-307 Bolts		ASTM A-325 or A-449 Bolts	
	Tension	Shear	Tension	Shear
1/4"– 20	625 lbs.	350 lbs.	1,250 lbs.	725 lbs.
3/8"– 16	1,500 lbs.	900 lbs.	3,100 lbs.	1,800 lbs.
1/2"– 13	2,800 lbs.	1,700 lbs.	5,600 lbs.	3,400 lbs.
5/8"– 11	4,500 lbs.	2,700 lbs.	9,000 lbs.	5,400 lbs.
3/4"– 10	6,600 lbs.	4,000 lbs.	13,300 lbs.	8,100 lbs.
7/8"– 9	9,200 lbs.	5,600 lbs.	18,400 lbs.	11,300 lbs.
1"– 8	12,100 lbs.	7,400 lbs.	24,200 lbs.	14,900 lbs.
1-1/8"– 7	15,200 lbs.	9,400 lbs.	26,700 lbs.	16,400 lbs.
1-1/4"– 7	19,300 lbs.	12,000 lbs.	33,900 lbs.	21,000 lbs.
1-1/2"– 6	28,100 lbs.	17,500 lbs.	49,100 lbs.	30,600 lbs.

Safe working loads shown provide a factor of safety of approximately 3 to 1 (ultimate to Safe Working Load). Shear Safe Working Load assumes that the threads are included in the shear plane. 1/4"–20, 3/8"–16 and 1/2"–13 bolts are not recommended for use as structural fasteners. For combined shear/tension interaction, refer to page 12.

Condition of Loadings

All safe working loads shown in this handbook are for static load conditions only. If dynamic forces or impact loading conditions are anticipated, the safe working load must be reduced accordingly.

Care must be exercised to see that all inserts and hardware units are properly aligned, all lifting plates and bolts properly secured, all rigging is equalized, and properly sized crane cables utilized.

Warning: When in doubt about the proper use or installation of a Dayton Superior precast product, contact Dayton Superior for clarification. Failure to do so may result in safety hazards, exposing workers in the vicinity of the precast yard or job site to the possibility of injury or death.

Corrosion Protection

The Dayton Superior precast products shown in this handbook are available in several different finishes or coatings. These finishes vary in the degree of corrosion protection provided. Standard finish is PLAIN and will normally be furnished if no finish is specified. Finishes available are as follows:

PLAIN or unfinished steel is sometimes referred to as BLACK or RAW. PLAIN finished material will rust when exposed to the environment.

ELECTRO-GALVANIZED finish is a zinc plated finish that provides a varying degree of corrosion protection depending on the thickness of the zinc plating and type of after-plating coating specified. This finish is recommended for threaded products. Dayton Superior electro-galvanizing conforms to ASTM Standard B-633, Service Condition 1 as plated. Other options available under this ASTM Standard are listed below.

HOT DIPPED GALVANIZED or HDG products are zinc coated by the hot-dipped process and will provide better corrosion protection than electro-galvanized finished products due to the thicker HDG zinc coating. This finish is not recommended for threaded products due to potential assembly problems. Dayton Superior hot dipped galvanizing conforms to ASTM A-123 or A-153.

EPOXY-POLYESTER or EPOXY finish is a dielectric material that is used to provide corrosion protection for steel products that are to be embedded in precast concrete. This material is usually applied to a coating thickness between 5 and 12 mils. Epoxy-Polyester finish is normally specified when an affordable solution to salt spray corrosion is required. Not recommended for use where threads are to be coated. STAINLESS STEEL is recommended for its excellent corrosion protection that will resist ordinary rusting. Type 304 Stainless Steel is recommended for use in precast products. It is the most economical type of stainless steel available for its level of corrosion resistance. Note that Type 304 Stainless Steel will rust when exposed to certain chemicals used to acid wash the surface of architectural precast concrete.

ASTM Standards For Corrosion Resisting Coatings

ASTM A-123 Zinc (Hot Dipped Galvanized) Coating on Iron or Steel

Product Type	Material	Approximate Thickness
Wire	.142" to .186" diameter	.002"
Wire	.187" to .249" diameter	.003"
Wire	.250" diameter or larger	.004"
Steel or Plate	.030" to .062" thick	.002"
Steel or Plate	.063" to .124" thick	.003"
Steel or Plate	.125" or thicker	.004"

ASTM A-153 Zinc Coatings (Hot Dip) on Iron or Steel Hardware

Product Type	Class	Approximate Thickness
Castings	A	.004"
Steel, 3/16" and thicker	B1	.004"
Steel, 3/16" and thinner	B2	.003"

ASTM B-633 Electro Deposited Coatings of Zinc on Iron and Steel

Service Condition	Exposure	Approximate Thickness
SC-4	.001"	Very Severe
SC-3	.0005"	Severe
SC-2	.0003"	Moderate
SC-1	.0002"	Mild

ASTM B-633 Continued

Type	After Plating Coating
1	As Plated
2	Colored Chromate
3	Colorless Chromate
4	Phosphate

Note: Electro-galvanized or hot dipped galvanized items fabricated from medium high carbon or high carbon steel must be properly treated to minimize hydrogen embrittlement. Failure to properly bake these items may result in a drastic reduction in their safe working load and premature failure resulting in property damage, injuries or death.

Condition of Loading

The preceding paragraphs have been devoted to the behavior of concrete inserts under straight tensile loading. Obviously, there are many conditions of loading other than direct tension. Most situations will require consideration of shearing and/or bending forces applied to the insert through the anchor bolt or other connecting hardware. A common condition occurs when a precast concrete element is lifted by means of inserts in each end without a spreader bar (see Illustration J). When a load **P** is carried by only two inserts, the vertical reaction **R** that must be carried by each insert is $1/2 P$. There is also an additional vertical force **V**, that must be added to **R**, that is caused by the horizontal component **H** of force **T**.

The horizontal force **H** that is exerted on the insert and on the concrete surrounding it is proportional to the total load and to the angle **a** included between the sling and the surface of the concrete. This force may be expressed by the equation:

$$H = \frac{P}{2} (\cot a).$$

The magnitude of the tensile force on the sling is proportional to the total load and to the angle **a**. This force may be expressed by the equation:

$$T = \frac{P}{2 \sin a}.$$

As angle **a** decreases, the values of **H** and **T** increase. As angle **a** approaches 0° , the magnitude of both **H** and **T** approaches infinity. Conversely, as angle **a** increases, the values of **H** and **T** decrease, so that as angle **a** approaches 90° , force **T** approaches the value of $1/2 P$ and force **H** approaches **0**.

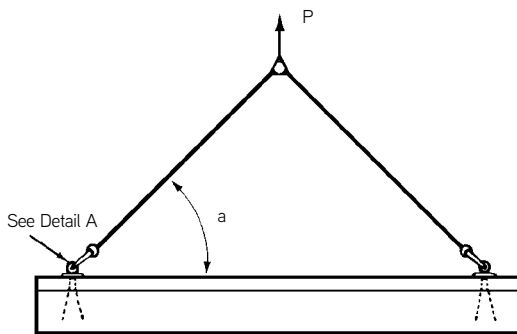
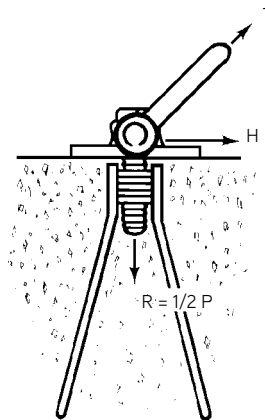

Illustration J



Detail A

It is readily apparent that the use of long slings will greatly reduce destructive forces on the slings, the lifting hardware and on the precast element itself.

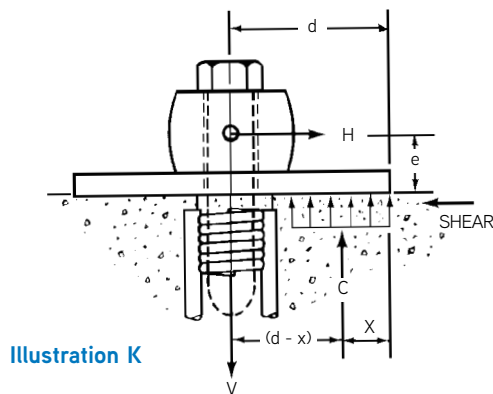

Illustration K

- H** = Horizontal component of sling load which is equal to the induced shear load.
- V** = Vertical force on insert caused by force **H** applied at distance **e** from face of concrete.
- C** = Resultant of compressive forces on concrete.
- d** = Distance from center line of anchor bolt to toe of bearing plate.
- e** = Distance from face of concrete to point of application of force **H**.
- x** = Distance from toe of bearing plate to **C**.
- b** = Width of bearing plate—(not shown)
- f_c** = Ultimate compression strength of the concrete.

Transverse and Shear Loading

A transverse force acting on an insert will cause a force pattern on the insert and in the surrounding concrete that is most easily visualized through a study of Illustration K.

Force H, when first applied, tends to cause a lateral translation and bending of the bolt. If the bolt has been properly tightened, a lateral movement will be prevented by frictional forces and, more importantly, by the couple of compressive force C exerted by the toe of the lifting plate on the concrete and the tensile force V.

Only under very rare circumstances will force H be applied at the face of the concrete. Usually, conditions are such that force H is applied at some distance "e" above the surface.

As long as the forces acting on the insert are in equilibrium, i.e., up to the point where some resisting element in the force system fails, the following equations express mathematically the balance of forces in and around the insert.

1. $(H) (e) = (C) (d-x)$
2. $V = C$
3. $(H) (e) = (V) (d-x)$
4. and $V = \frac{(H) (e)}{(d-x)}$

The only value on the right hand side of this equation that cannot be definitely determined is dimension x. This distance is determined by the compressive stress pattern under the lifting plate.

If the pattern is triangular:

$$5. C_{max} = \left(\frac{1}{2} f'_c\right) (db) \text{ and } x = \frac{d}{3}$$

If the pattern is rectangular:

$$6. C_{max} = (f'_c) (db) \text{ and } x = \frac{d}{2}$$

More probably, the pattern is a trapezoidal compromise and:

$$7. C_{max} = (.85 f'_c) (db) \text{ and } x = 5/12 d.$$

For any given lifting plate, the value of C_{max} will be limited by f'_c or by V_{max} which is the pull out strength of the insert, since, by equation (2) $V = C$.

Test results indicate that the assumption of a rectangular stress pattern is valid and conservative for most conditions.

$$8. \text{Equation (4) then becomes } V = \frac{2(e)(H)}{d}$$

Values $\frac{2e}{d}$ for Dayton Superior Lifting Hardware are shown in the Table below.

Warning: Lifting plates or other attachment hardware must be bolted tightly to the concrete, and bolt holes in the plate must not be excessively larger than the anchor bolt. Disregard for these precautions can cause bolt bending, excessive unbalanced loading on the insert and possibly a premature failure.

Applying equation (8) to a specific situation: Assume that a B18 3/4" x 9" Single Flared Coil Loop Insert is being used (safe working load is 4,750 lbs.) together with a T12 Swivel Lifting Plate in such a manner that the vertical component of the load on the insert is 4,500 lbs. and the horizontal component of load on the insert is 1,000 lbs.

Using equation (8), $V = 2 \frac{(e)(H)}{d}$, and values of $\frac{2e}{d}$

from the table, $V = .65 \times 1000 \text{ lbs.}$ or 650 lbs. of additional pull on the insert caused by the horizontal component. Adding: 4,500 lbs. + 650 lbs. = 5,150 lbs. This exceeds the rated load of the insert and requires that a stronger insert be chosen.

Lifting Hardware Values

Lifting Plate	Bolt Diameter	$\frac{2e}{d}$
T8	1", 1-1/4" or 1-1/2"	2.00
T12	3/4"	0.65
T12	1"	0.67
T12H	1-1/4"	0.83
T12H	1-1/2"	0.83
T26H	3/4"	1.46
T26	1"	1.00
T26H	1"	1.46
T26	1-1/2"	0.71
T27	3/4" or 1"	3.00

Calculating Sling/Anchor Loads

Applies to Swift Lift; Fleet-Lift and Utility Anchors

The table shows multiplication factors that are used in a simplified method to determine the increased load transferred from the sling to the anchor when using multi-leg slings. As the fleet angle (θ) increases, the sling load increases and transfers an even larger to the anchor.

Fleet Angle " θ "	Multiplication Factor " F "
0°	1.00
16°	1.01
30°	1.04
45°	1.08
60°	1.16
75°	1.26
90°	1.41
105°	1.64
120°	2.00

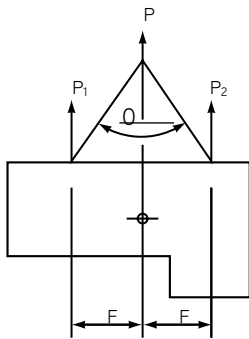

Warning: Avoid the use of Fleet Angles greater than 120° as their use can overload and damage anchors causing a premature failure resulting in property damage, serious personal injury or death.

P = Actual weight of precast element including adhesion

θ = Fleet angle

F = Multiplication factor

$P \times F$ = Effective weight of precast element

$P_1 = P_2$ = Anchor load using 2-leg sling

$P_1 = P_2 = P \times F / 2$ anchors

Calculating Sling/Anchor Loads

Applies to Swift Lift; Fleet-Lift and Utility Anchors

When anchors are not located equally about the center of gravity of the precast element, calculate the applied anchor loads statically.

The load will always balance under the crane hook. Calculate anchor loads as follows:

$$P_1 = P \times b / a + b$$

$$P_2 = P \times a / a + b$$

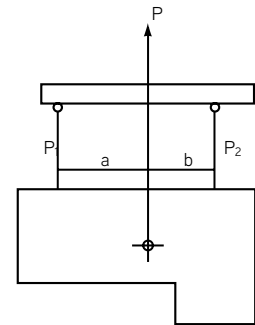

Rigging For Traveling Over Rough Ground

When a precast element is to be transported over rough ground, use a 60° "V" type rigging. This will help reduce dynamic loads.

When using a forklift to transport precast elements over rough ground, Dayton Superior recommends that the user reduce the anchor safe working load by 50%. This safe working load reduction will help offset the effects of any dynamic loads that might occur.

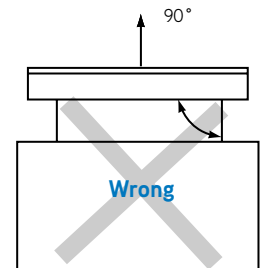
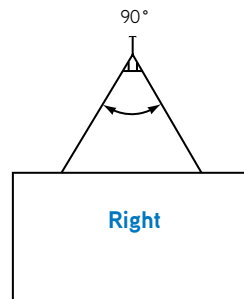
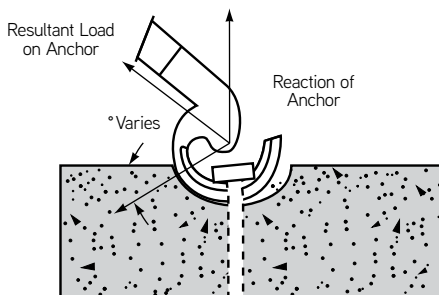

Load Diagram Compressive Force in Concrete

Rigging

As with all lifting systems, the selection of the proper lifting anchor is based on several factors. One of the most important is the accurate determination of the load that will be applied to each anchor. When using certain rigging arrangements it is impossible to accurately determine the load that is applied to each anchor. This is due to the tolerances in sling lengths and the location of the lifting anchors in the precast concrete element. In order to eliminate this problem, and make certain that the applied loads are equalized to each of the lifting anchors, an equalizer (spreader) beam and rollers blocks are used.

The use of equalizer beams and roller blocks permits a qualified person to determine the exact load distribution. When an equalizer beam and roller blocks are used in the plant, they must also be used in the field. If the user is in doubt about the field use of an equalizer beam and roller blocks, then only two anchors should be assumed to be load carrying.

Several typical rigging arrangements are shown below along with a determination as to the number of anchors that will be load carrying.

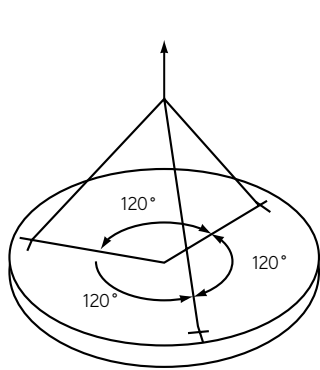

Illustration R1

3 anchors will carry load when used on round precast concrete elements with the anchors spaced 120° apart. 2 anchors will carry load when used on square or rectangular precast elements.

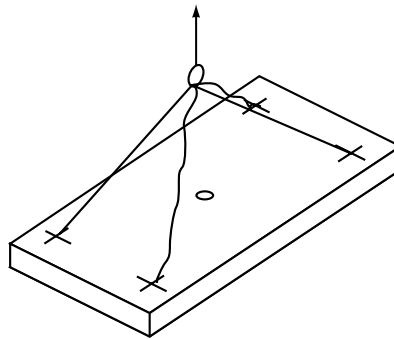

Illustration R2

2 anchors will carry load when using 4 individual slings. The other 2 anchors will act to balance the precast concrete element.

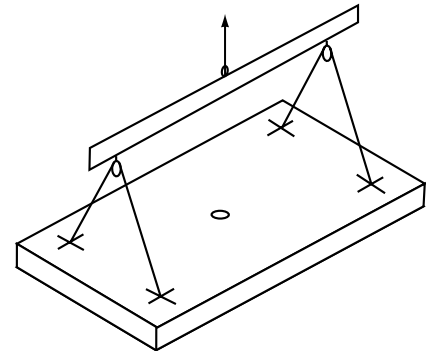

Illustration R3

4 anchors will carry load when using 2 individual slings running over 2 roller blocks supported by an equalizer beam.

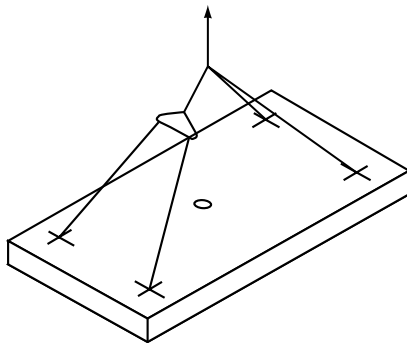

Illustration R4

4 anchors will carry load when using 4 individual slings in conjunction with the Dayton Superior T46 Spreader Beam with Twin 7-1/2-ton Shackles.

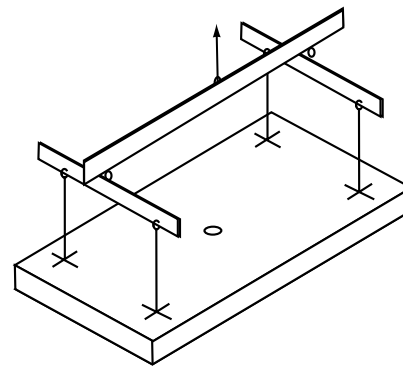

Illustration R5

2 anchors will carry load when using 4 individual slings attached to a 3 beam equalizer beam. This rigging arrangement should be used when angle pulls need to be avoided.

The above assumes that the anchors are spaced equally about the center of gravity of the precast concrete element and that the center of lift is directly above the center of gravity. Failure to locate the center of lift directly over the center of gravity will cause the precast element to tilt.

Selecting the Proper Insert

The following factors should be considered when determining the load per insert:

- 1) Weight of the concrete shape,
- 2) Adhesion to the form surface,
- 3) Type of concrete (normal, lightweight or all lightweight materials),
- 4) Dynamic loads (impact due to handling, transporting or erecting conditions),
- 5) Concrete compressive strength at time of initial lift,
- 6) Number of lifting points and type of rigging to be used,
- 7) Direction of pull (cable or sling angle),
- 8) Flexural stresses of thin concrete shapes,
- 9) Panel thickness,
- 10) Edge distance (thin wall, free edge or shear loading conditions).

Determining the dead load weight of a precast concrete section is straight forward, although serious errors are easy to make, such as: 1. Miscalculations involving symmetrical panels; 2. Forgetting that a panel is normal weight concrete and using the unit weights of lightweight concrete and 3. Neglecting adhesion to the form.

In addition, transporting the panel in the storage yard over bumpy conditions introduces dynamic loads that must also be anticipated. Removing the precast element from the form can induce forces that, in effect, increase the dead load weight at a critical time, when the concrete compressive strength is at its lowest value. Depending on the quality of release agent used, the following adhesion loads should be considered when determining the "additional" weight of the concrete element:

Concrete Forms	up to 20 lbs./sq. ft.
Steel Forms	up to 25 lbs./sq. ft.
Plywood Forms (Flat Surface)	up to 50 lbs./sq. ft.
Plywood Forms (Ribbed Surface)	up to 75 lbs./sq. ft.

The type of concrete used determines the unit weight characteristics and the resultant ability of the concrete to resist the pullout forces introduced by the insert. See page 8 for the proper load reduction factors that must be applied to insert safe working loads when an insert is embedded in lightweight concrete.

Consideration must also be given to dynamic loads that can occur in the plant, in the storage yard, as well as during transportation to the job site and during erection. It is suggested that a detailed study be made of the various handling, storage, transporting and erection forces. The user is cautioned to be aware of these additional forces and to give due consideration to their effect on the insert's safe working load.

Example One

Select the proper length and capacity of insert based on the use of a spreader frame, as shown below, that will allow equal loading on all four inserts. Assume normal weight concrete having a compressive strength of 2,700 psi at initial lift.

$$\begin{aligned} \text{Dead Load Weight} &= 15' \times 8' \times 12.5 \text{ lbs./sq. ft.} \times 6" = && 9,000 \text{ lbs.} \\ \text{Adhesion to Form} &= 15' \times 8' \times 75 \text{ lbs./sq. ft.} = && \underline{9,000 \text{ lbs.}} \\ &\text{(Ribbed Surface)} \\ \text{Effective Weight of Panel} &= && 18,000 \text{ lbs.} \\ \text{Required Insert Capacity} &= \frac{18,000 \text{ lbs.}}{4 \text{ inserts}} = && 4,500 \text{ lbs./insert} \end{aligned}$$

$$\text{Maximum Insert Height} = 5-1/2"$$

Select the following insert: P52 4 ton x 4¾" long Swift Lift Anchor in 3,000 psi normal weight concrete.

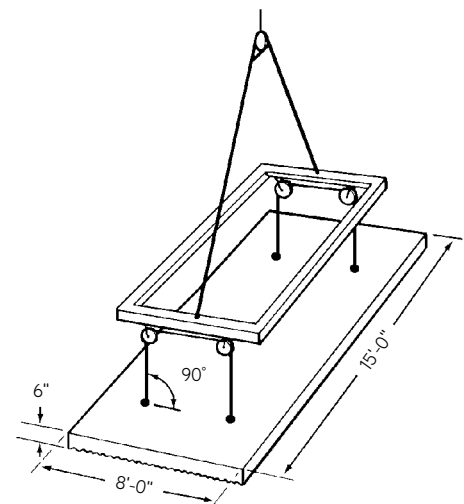

Illustration M

Example Two

Select the proper length and capacity of insert, based on the use of a spreader beam and slings at a 60° angle with the top surface of the precast section. Assume normal weight concrete having a compressive strength of 4,000 psi at initial lift and the use of 1" diameter T12 Swivel Lifting Plates.

$$\begin{aligned} \text{Dead Load Weight} &= 20' \times 7' \times 12.5 \text{ lbs./sq. ft.} \times 6" = 10,500 \text{ lbs.} \\ \text{Adhesion to Form} &= 20' \times 7' \times 25 \text{ lbs./sq. ft.} = \underline{3,500 \text{ lbs.}} \\ \text{Effective Weight of Panel} &= \underline{14,000 \text{ lbs.-}} \end{aligned}$$

Therefore, the vertical reaction that must be carried by each

$$\text{insert} = \frac{14,000 \text{ lbs.}}{4 \text{ inserts}} = 3,500 \text{ lbs.}$$

$$H = 3,500 \text{ lbs.} \times \cot. 60^\circ = 3,500 \text{ lbs.} \times .578 \text{ or}$$

$$H = 2,023 \text{ lbs./insert}$$

$$V = \frac{2e}{d} \times 2,023 \text{ lbs.} = .65 \times 2,023 \text{ or}$$

$$V = 1,315 \text{ lbs./insert}$$

$$\begin{aligned} \text{Required Insert Capacity} &= 3,500 \text{ lbs.} + 1,315 \text{ lbs.} \\ &= 4,815 \text{ lbs./insert} \end{aligned}$$

Maximum Insert Height = 5½"

Select the following insert: F56 Expanded Coil Insert,
1" diameter x 5-1/2" long,
6,250 lbs. Safe Working Load.

Check combined tension and shear as follows:

$$\left(\frac{4,815 \text{ lbs.}}{6,250 \text{ lbs.}} \right)^{5/3} + \left(\frac{2,023 \text{ lbs.}}{4,800 \text{ lbs.}} \right)^{5/3} = .80. \text{ Since this is less than 1.0, the insert which was selected is suitable for use.}$$

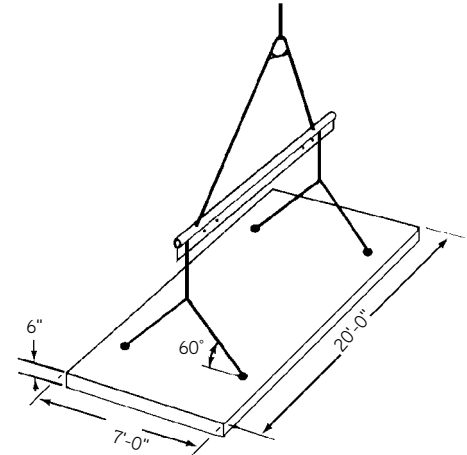

Illustration N

Example Three

Select the proper length and capacity of an insert based on the use of a four sling lift (see warning note below) with cables at a 60° angle to the top surface of the precast section. Assume lightweight concrete having a unit weight of 115 lbs./cu. ft., a compressive strength at initial lift of 4,000 psi and the use of 1-1/2" diameter T12 Swivel Lift Plates.

$$\begin{aligned} \text{Dead Load Weight} &= 9' \times 10' \times 9.58 \text{ lbs./sq. ft.} \times 14" = 12,071 \text{ lbs.} \\ \text{Adhesion to Form} &= 9' \times 10' \times 20 \text{ lbs./sq. ft.} = \underline{1,800 \text{ lbs.}} \\ \text{Effective Weight of Precast Section} &= \underline{13,871 \text{ lbs.}} \end{aligned}$$

Therefore, the vertical reaction that must be carried by each

$$\text{insert} = \frac{13,871 \text{ lbs.}}{2 \text{ inserts}} = 6,936 \text{ lbs.}$$

$$H = 6,936 \text{ lbs.} \times \cot. 60^\circ = 6,936 \text{ lbs.} \times .578 \text{ or}$$

$$H = 4,009 \text{ lbs./insert}$$

$$V = \frac{2e}{d} \times 4,009 \text{ lbs.} = .833 \times 4,009 \text{ lbs. or}$$

$$V = 3,339 \text{ lbs./insert}$$

$$\text{Required Insert Capacity} = 6,936 \text{ lbs.} + 3,339 \text{ lbs.} = 10,275 \text{ lbs./insert}$$

Maximum Insert Height = 13-1/2"

Select the F60 Expanded Coil Insert, 1-1/2" diameter x 12" long, 16,250 lbs. Safe Working Load.

Multiply Safe Working Load by reduction factor of .7 for lightweight concrete,

$$16,250 \text{ lbs.} \times .7 = 11,375 \text{ lbs. Safe Working Load in lightweight concrete.}$$

As the reduced Safe Working Load is greater than the 10,275 lbs. load required, it appears this insert is suitable for use. However, combined shear and tension must be checked as follows:

$$\left(\frac{10,275 \text{ lbs.}}{11,375 \text{ lbs.}} \right)^{5/3} + \left(\frac{4,009 \text{ lbs.}}{11,750 \text{ lbs.}} \right)^{5/3} = 1.01, \text{ which means this insert must be replaced with a stronger insert.}$$

Warning: When individual slings are used, any two inserts must be capable of lifting/handling the precast section. This is due to unequal sling lengths and the resulting loads that are transferred to the shorter slings. In this application, only two slings carry the total load while the other two slings are simply used to balance the load.

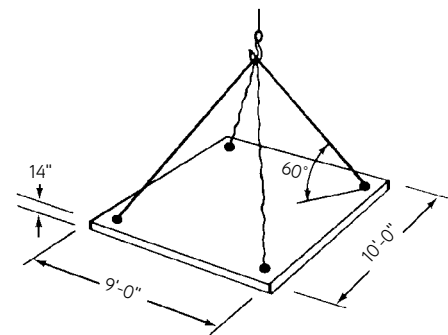
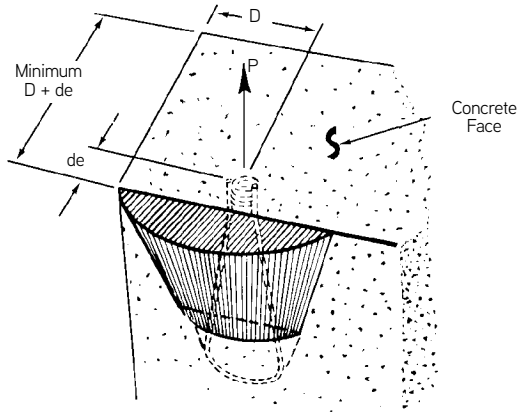

Illustration P

Coil Insert Safe Working Load Reduction Factors For Free Edge Conditions – Tension Loadings Only



de = Free edge distance

D = Minimum edge distance required to develop a full shear cone is 1.5 x the insert length

2D = Minimum insert spacing when using two or more inserts

Note: For insert capacities under shear loading conditions, please refer to "Transverse and Shear Loading".

Insert Type and Length

de	B1 or B2			B16		B17	B18		B33	F53		F56 to F61				F63		
	6"	8"	12"	4"	6"	12"	9"	12"	12"	3"	4"	4-1/2"	5-1/2"	7-1/2"	9-1/2"	2-2/8"	3-1/2"	4-1/2"
2"	-	-	-	0.67	0.61	-	0.57	0.58	-	0.72	0.67	-	-	-	-	0.79	0.69	0.65
2-1/4"	0.63	0.59	0.59	0.69	0.63	-	0.58	0.59	-	0.75	0.69	0.67	-	-	-	0.82	0.71	0.67
2-1/2"	0.64	0.60	0.60	0.71	0.64	-	0.59	0.60	-	0.78	0.71	0.69	0.65	0.61	-	0.86	0.74	0.69
2-3/4"	0.65	0.61	0.61	0.73	0.65	-	0.60	0.61	-	0.81	0.73	0.70	0.67	0.62	0.60	0.90	0.76	0.70
3"	0.67	0.63	0.63	0.75	0.67	-	0.61	0.63	-	0.83	0.75	0.72	0.68	0.63	0.61	0.93	0.79	0.72
3-1/2"	0.69	0.65	0.65	0.79	0.69	-	0.63	0.65	-	0.89	0.79	0.76	0.71	0.66	0.62	1.00	0.83	0.76
4"	0.72	0.67	0.67	0.83	0.72	0.67	0.65	0.67	0.67	0.94	0.83	0.80	0.74	0.68	0.64	1.00	0.88	0.80
4-1/2"	0.75	0.69	0.69	0.88	0.75	0.69	0.67	0.69	0.69	1.00	0.88	0.83	0.77	0.70	0.66	1.00	0.93	0.83
5"	0.78	0.71	0.71	0.92	0.78	0.71	0.69	0.71	0.71	1.00	0.92	0.87	0.80	0.72	0.68	1.00	0.98	0.87
5-1/2"	0.81	0.73	0.73	0.96	0.81	0.73	0.70	0.73	0.73	1.00	0.96	0.91	0.83	0.74	0.69	1.00	1.00	0.91
6"	0.83	0.75	0.75	1.00	0.83	0.75	0.72	0.75	0.75	1.00	1.00	0.94	0.86	0.77	0.71	1.00	1.00	0.94
7"	0.89	0.79	0.79	1.00	0.89	0.79	0.76	0.79	0.79	1.00	1.00	1.00	0.92	0.81	0.75	1.00	1.00	1.00
8"	0.94	0.83	0.83	1.00	0.94	0.83	0.80	0.83	0.83	1.00	1.00	1.00	0.98	0.86	0.78	1.00	1.00	1.00
9"	1.00	0.88	0.88	1.00	1.00	0.88	0.83	0.88	0.88	1.00	1.00	1.00	1.00	0.90	0.82	1.00	1.00	1.00
10"	1.00	0.92	0.92	1.00	1.00	0.92	0.87	0.92	0.92	1.00	1.00	1.00	1.00	0.94	0.85	1.00	1.00	1.00
11"	1.00	0.96	0.96	1.00	1.00	0.96	0.91	0.96	0.96	1.00	1.00	1.00	1.00	0.99	0.89	1.00	1.00	1.00

Reduced Safe Working Load is based on 1/2" setback from face of concrete.

For Safe Working Load on other insert loading conditions, contact a Dayton Superior Technical Service Department.

Above chart modified from ACI 318 Appendix D method by using previous results from product testing.

How to Use Reduction Factors:

To obtain an insert's reduced safe working load for free edge conditions, multiply the safe working load listed in the insert selection chart by the appropriate reduction factor from the above chart. Do not apply these reduction factors to other types or sizes of inserts.

Example:

Using a B2 Coil Tie Insert 1" x 8" long in a 2-1/2" free edge condition, multiply concrete safe working load of 9,514 lbs. by a reduction factor of 0.6 to arrive at the reduced concrete safe working load of 5,708 lbs. which is less than insert mechanical capacity of 9,000 lbs. so use 5,708 lbs.

Coil Insert Safe Working Load Reduction Factors For Thin Wall Conditions – Tension Loadings Only

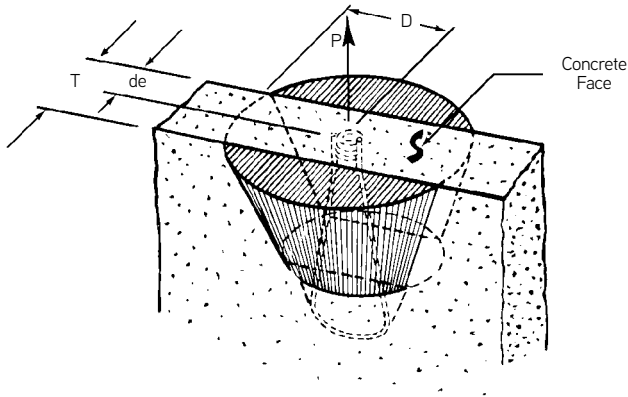

- T = Wall thickness
- de = Actual edge distance
- D = Minimum edge distance required to develop a full shear cone is 1.5 x the insert length
- 2D = Minimum insert spacing when using two or more inserts

Note: For insert capacities under shear loading conditions, please refer to *Selecting the Proper Insert* section.

Insert Type and Length

T	de	B1 or B2			B16		B17	B18		B33	F53		F56 to F61				F63		
		6"	8"	12"	4"	6"	12"	9"	12"	12"	3"	4"	4-1/2"	5-1/2"	7-1/2"	9-1/2"	2-2/8"	3-1/2"	4-1/2"
4"	2"	-	-	-	0.33	0.22	-	0.15	0.17	-	0.44	0.33	-	-	-	-	0.58	0.38	0.30
4-1/2"	2-1/4"	0.25	0.19	0.19	0.38	0.25	-	0.17	0.19	-	0.50	0.38	0.33	-	-	-	0.65	0.43	0.33
5"	2-1/2"	0.28	0.21	0.21	0.42	0.28	-	0.19	0.21	-	0.56	0.42	0.37	0.30	0.22	-	0.72	0.48	0.37
5-1/2"	2-3/4"	0.31	0.23	0.23	0.46	0.31	-	0.20	0.23	-	0.61	0.46	0.41	0.33	0.24	0.19	0.79	0.52	0.41
6"	3"	0.33	0.25	0.25	0.50	0.33	-	0.22	0.25	-	0.67	0.50	0.44	0.36	0.27	0.21	0.86	0.57	0.44
7"	3-1/2"	0.39	0.29	0.29	0.58	0.39	-	0.26	0.29	-	0.78	0.58	0.52	0.42	0.31	0.25	1.00	0.67	0.52
8"	4"	0.44	0.33	0.33	0.67	0.44	0.33	0.30	0.33	0.33	0.89	0.67	0.59	0.48	0.36	0.28	1.00	0.76	0.59
9"	4-1/2"	0.50	0.38	0.38	0.75	0.50	0.38	0.33	0.38	0.38	1.00	0.75	0.67	0.55	0.40	0.32	1.00	0.86	0.67
10"	5"	0.56	0.42	0.42	0.83	0.56	0.42	0.37	0.42	0.42	1.00	0.83	0.74	0.61	0.44	0.35	1.00	0.95	0.74
11"	5-1/2"	0.61	0.46	0.46	0.92	0.61	0.46	0.41	0.46	0.46	1.00	0.92	0.81	0.67	0.49	0.39	1.00	1.00	0.81
12"	6"	0.67	0.50	0.50	1.00	0.67	0.50	0.44	0.50	0.50	1.00	1.00	0.89	0.73	0.53	0.42	1.00	1.00	0.89
14"	7"	0.78	0.58	0.58	1.00	0.78	0.58	0.52	0.58	0.58	1.00	1.00	1.00	0.85	0.62	0.49	1.00	1.00	1.00
16"	8"	0.89	0.67	0.67	1.00	0.89	0.67	0.59	0.67	0.67	1.00	1.00	1.00	0.97	0.71	0.56	1.00	1.00	1.00
18"	9"	1.00	0.75	0.75	1.00	1.00	0.75	0.67	0.75	0.75	1.00	1.00	1.00	1.00	0.80	0.63	1.00	1.00	1.00
20"	10"	1.00	0.83	0.83	1.00	1.00	0.83	0.74	0.83	0.83	1.00	1.00	1.00	1.00	0.89	0.70	1.00	1.00	1.00
22"	11"	1.00	0.92	0.92	1.00	1.00	0.92	0.81	0.92	0.92	1.00	1.00	1.00	1.00	0.98	0.77	1.00	1.00	1.00

Reduced Safe Working Load is based on 1/2" setback from face of concrete.

For Safe Working Load on other insert loading conditions, contact a Dayton Superior Technical Service Department.

When an insert is not positioned at the center line of the wall, the effective wall thickness is twice the actual edge distance. Above chart modified from ACI 318 Appendix D method by using previous results from product testing.

How to Use Reduction Factors:

To obtain an insert's reduced safe working load for thin wall conditions, multiply the safe working load listed in the insert selection chart by the appropriate reduction factor from the above chart. Do not apply these reduction factors to other types or sizes of inserts.

Example:

Using a B2 Coil Tie Insert 1" x 12" long in an 8" thin wall, multiply concrete full shear cone capacity of 17,525 by a reduction factor of 0.33 to arrive at the reduced concrete safe working load of 5,783 lbs. which is less than insert mechanical capacity of 9,000 lbs. so use 5,783 lbs.

Swift Lift® System

The Swift Lift System is a quick connect-disconnect system that allows precast concrete elements to be handled repeatedly, with speed, safety and economy. It is a non-welded system and void of threaded connections. The quality, reusable Swift Lift Lifting Eye's heavy duty construction will provide years of good service.

The Swift Lift System is available with safe load ratings of 1, 2, 4, 8 and 20 tons. Each component is clearly marked with its maximum safe working load. The System is extremely versatile and can be utilized for vertical and diagonal pulls. It can be used to lift concrete elements from a horizontal to a vertical position without the aid of a tilting table.

P50 Swift Lift® Universal Lifting Eye

The Swift Lift Universal Lifting Eye (P50) consists of a flat-sided, spherical lifting body and a high strength bail. The lifting body has a T-shaped slot that permits rapid attachment and release of the head on Swift Lift Anchors.

The design of the P50 Universal Lifting Eye permits the bail to freely rotate 180°, while the complete lifting eye may rotate through a 360° arc. This design feature allows precast concrete elements to be turned, tilted and/or rotated under load.

Dayton Superior does not recommend the use of this lifting eye for edge lifting of thin precast concrete panels.

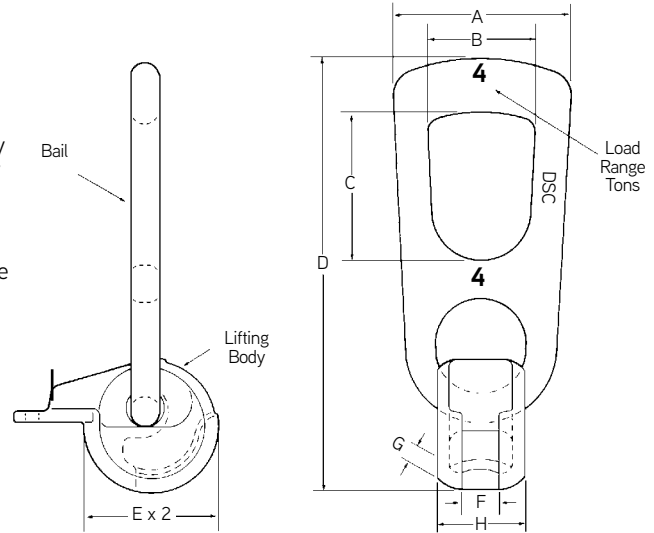

P50 Swift Lift Universal Lifting Eye Dimensions

Rated Load Tons	A	B	C	D	E x 2	H
1	2.9"	1.7"	2.8"	7.5"	2.20"	1.26"
2	3.5"	2.3"	3.3"	9.0"	2.68"	1.65"
4	4.6"	2.8"	3.5"	11.0"	3.46"	2.26"
8	6.3"	3.3"	4.4"	15.6"	4.40"	2.90"
20	7.3"	4.6"	5.9"	20.4"	5.98"	4.35"

The rated load provides a factor of safety of approximately 5 to 1 (ultimate to rated load).

P50 Inspection and Maintenance

The P50 Universal Lifting Eye may be subjected to wear, misuse, overloading and other factors that can affect the lifting eye's rated load. Therefore, it is imperative that the lifting eye be user-inspected at least once a month to determine its general condition and degree of wear.

During the user's monthly inspection, the lifting eye should be checked for evidence of heat application. If evidence of heat application is found, the unit must be scrapped. Check for a bent or twisted bail and discard all units found to have these flaws. Also, check to make certain that the bail rotates freely in all directions.

At least once every three months, dimensions "F" and "G" on each unit should be checked. The upper limits are shown in the chart. If either of these limits is exceeded, the P50 Universal Lifting Eye must be removed from service and destroyed.

The proper method for scrapping a lifting eye is to cut through the bail with a cutting torch to render the unit useless as a lifting device.

No repairs or welding to the P50 Swift Lift Universal Lifting Eye are permitted.

Limiting Dimensions on P50 Swift Lift Universal Lifting Eye

Rated Load (Tons)	F Maximum Width	G Minimum Thickness
1	0.56"	0.22"
2	0.76"	0.23"
4	1.02"	0.31"
8	1.31"	0.47"
20	1.86"	0.71"

How to Use the P50 Swift Lift Universal Lifting Eye

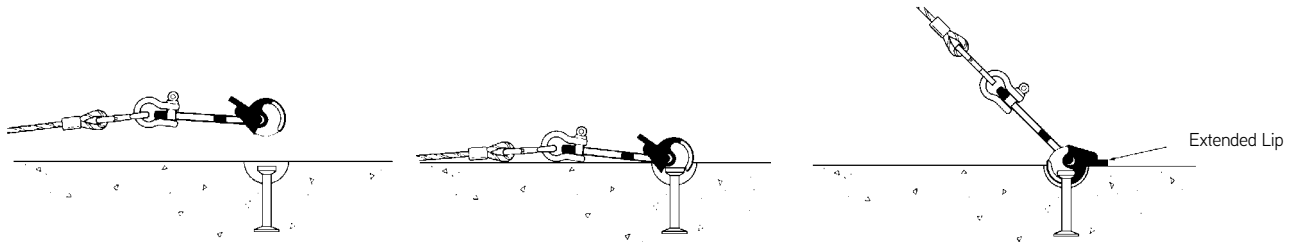

1. To install the P50 lifting eye, hold the unit upside down with the T-shaped slot directly over the head of the Swift Lift anchor.
2. Lower the lifting eye down onto the anchor until the T slot engages the head of the anchor.
3. Rotate the lifting eye until the extended lip of the body touches the horizontal surface of the concrete.

Note: Prior to lifting a precast element, apply an initial cable tension to make sure that the bail and body of the lifting eye are aligned in the direction of the cable pull.

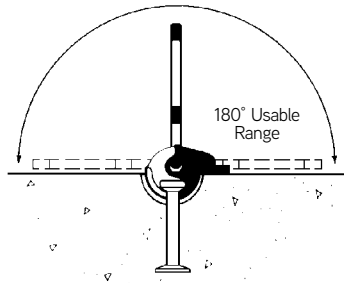

The bail of the P50 lifting eye can move through a 180° usable range.

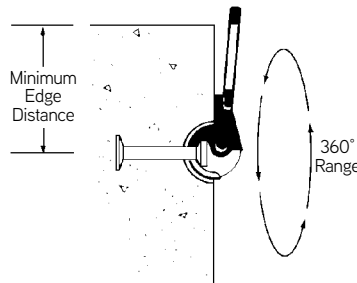

The main body of the lifting eye has a 360° rotational range.

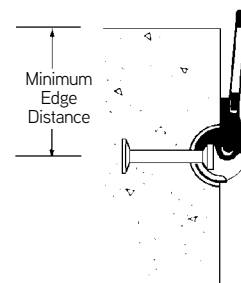

The P50 lifting can be safely used with the T-shaped slot facing away from or toward the direction of the applied load.

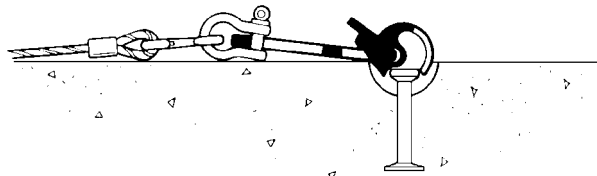

To disengage the lifting eye, the crane hook is lowered and the body removed by rotating the extended lip upward.

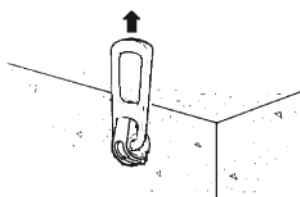

Right

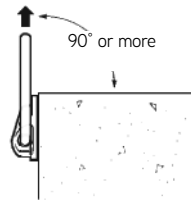

Right

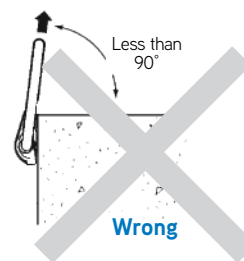

Wrong

Dos and Don'ts of the P50 Swift Lift Universal Lifting Eye

Prior to lifting a precast element, apply an initial cable tension to make certain that the bail and body of the lifting eye are aligned in the direction of the cable pull.

When applying the initial cable tension on

Warning: The crane line and bail of the lifting hardware must be turned in the direction of the cable forces before the lifting operation begins. The crane line must not be allowed to apply a sideward force on the bail. This condition is dangerous and could lead to premature failure of the hardware or insert.

Warning: Do not modify, weld or alter in any way the Swift Lift Universal Lifting Eye.

edge lift applications, make sure that the cables are at a 90° angle (or larger) to the surface of the precast element.

Warning: Do not allow the crane lines to form an angle less than 90° during an edge lift application. This

condition can bend the lifting eye bail and could lead to a premature failure.

P51 Swift Lift® Lifting Eye

The P51 Swift Lift Lifting eye is a high quality, high strength steel casting. Its ball-shaped lower end fits into the void formed in the concrete and engages the spherical head of the anchor. Attachment to the anchor head can only be made when the lifting eye is positioned with its front face toward the concrete. In the working position, release is impossible. Accidental disengagement is prevented by a gravity-action safety pin that must be raised before the Lifting Eye can be removed.

The P51 Swift Lift Lifting Eye is available with safe working loads of 2, 4 and 8 tons. It is extremely versatile in use, being suitable for vertical pull or diagonal pull. The Lifting Eye rotates freely (360°) about the vertical axis of the anchor. Each unit is clearly marked with its MAXIMUM safe working load.

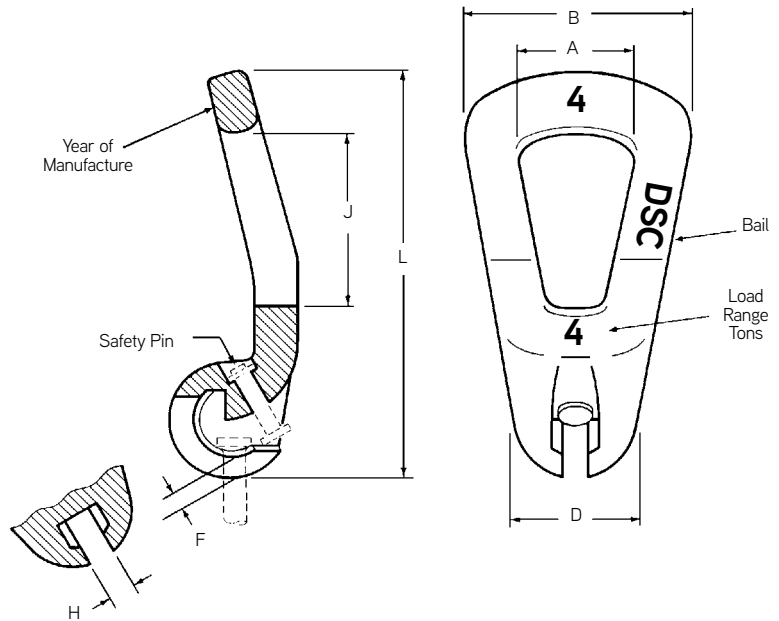

P51 Swift Lift Lifting Eye Dimensions

Rated Load Tons	A	B	D	J	L
2	2.63	4.53	2.36	3.74	8.43
4	3.02	5.13	2.83	4.96	10.35
8	3.53	5.98	3.70	5.60	12.87

Safe Working Load provides a factor of safety of approximately 5 to 1.

Inspection and Maintenance

While appreciable wear does not normally occur, the P51 Swift Lift Lifting Eye may be subjected to wear, misuse, overloading and other factors that may affect the lifting eye's rated load. Therefore, the user must inspect lifting eyes at least once a month to determine general condition, degree of wear and any evidence of heat application.

If evidence of heat application is found, the unit must be destroyed. In addition, check to make certain that the bail is not bent or twisted. Destroy all units that have a bent or twisted bail.

Check the safety pin; missing pins must be replaced. Make sure the safety pin is in good condition and moves freely at all times. At least once every three months, dimension "G" on each unit should be checked. The upper limits are shown in the chart. If either of these limits is exceeded, the Swift Lift Lifting Eye must be removed from service and destroyed.

The proper method to use in destroying a lifting eye is to cut through the bail with a cutting torch. Other than replacing the safety pin, no repairs to the P51 Swift Lift Lifting Eye are permitted. In particular, welding is not permitted.

Limiting Dimensions on P51 Swift Lift Lifting Eye

Rated Load (Tons)	H (Maximum)
2	0.759"
4	1.034"
8	1.310"

How to Install The P51 Swift Lift® Lifting Eye

To engage the P51 Swift Lift Lifting Eye on the head of the Swift Lift Anchor, position the P51 Swift Lift Lifting Eye so that the front face is toward the concrete, then raise the Swift Lift Lifting Eye into the working position and engage the lifting hook. The safety pin will drop into position to prevent accidental release of the Swift Lift Lifting Eye.

For inclined pulls, the front face of the P51 Swift Lift Lifting Eye, which indicates the rated load of the lifting eye, must always be facing away from the concrete surface. This must be checked immediately before the lifting operation begins.

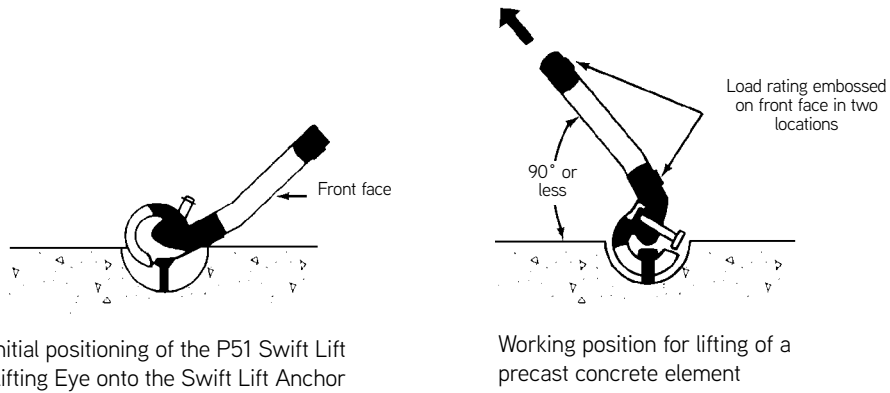

Warning: If the P51 Swift Lift Lifting Eye is used when its relative position is 90° or 180° from its correct position, the P52 Swift Lift Anchor will be overloaded and may result in a premature failure.

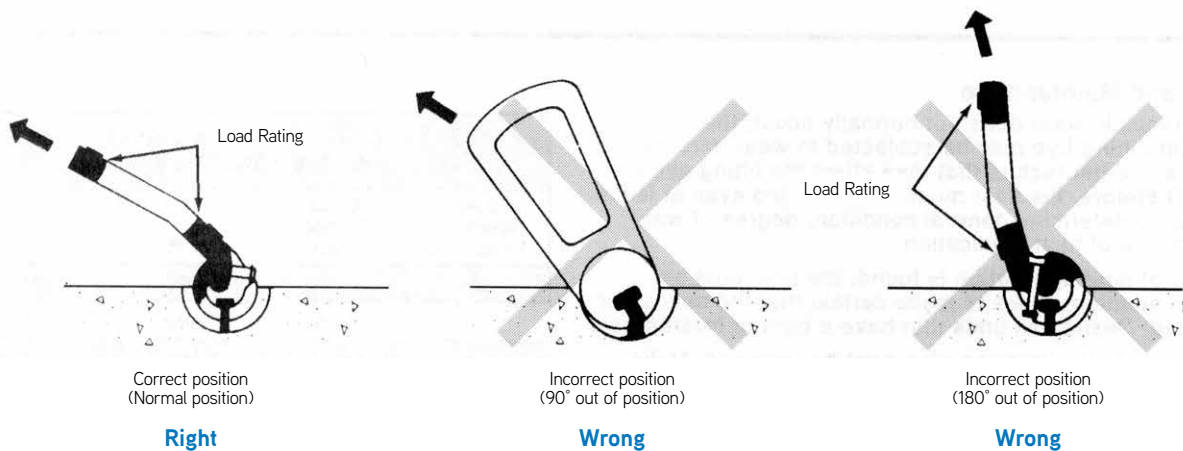

Note: Do not use the lifting eye in this manner as it could bend and/or break the safety pin, allowing the lifting eye to pull off the Swift Lift Anchor. Never use lifting eye without a safety pin in place.

How to use the P51 Swift Lift® Lifting Eye

When the P51 Swift Lift Lifting Eye's position is changed from a diagonal pull to a vertical pull relative to the anchor axis, all movements are permissible, even with simultaneous rotation.

If the Swift Lift Anchor is positioned in a relatively thin panel, movement of the P51 Swift Lift Lifting Eye under load from the vertical to an inclined position relative to the axis of the anchor (such as laying down a panel with edge inserts as shown in 1 below) is NOT PERMITTED due to excessive friction. This friction causes binding of the ball end of the P51 Swift Lift Lifting Eye, and when the friction is overcome, the resultant sudden movement causes high impact stresses on the surrounding concrete. As an aid in reducing friction, apply a soap solution to the void formed by the recess plug.

The above maneuver can be accomplished when the proper rigging is used. The fleet angle between the slings must be between 90° and 120°. In this manner, precast concrete shapes can be placed from the vertical to the horizontal.

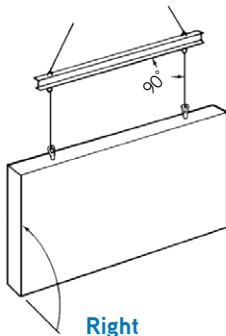

Right

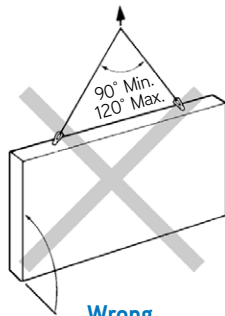

Wrong

1. Maneuvering from horizontal to vertical with edge anchors

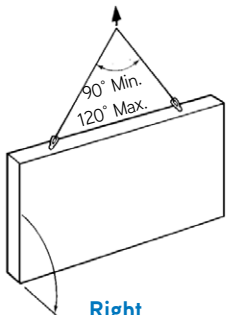

Right

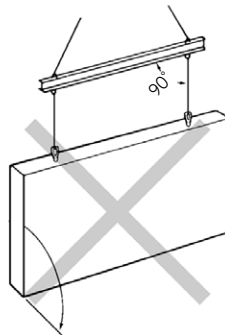

Wrong

2. Maneuvering from vertical to horizontal with edge anchors
Note: To reduce friction between the Swift Lift Lifting Eye and the concrete, apply a soap solution to the cavity formed by the recess plug.

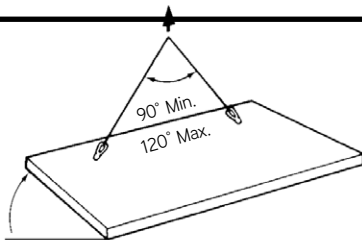

Right

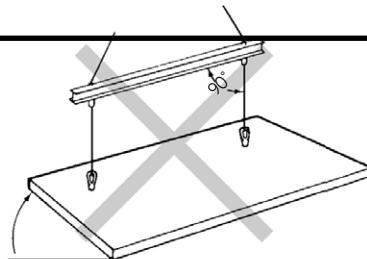

Wrong

3. Maneuvering from horizontal to vertical with face anchors
Note: To reduce friction between the Swift Lift Lifting Eye and the concrete, apply a soap solution to the cavity formed by the recess plug.

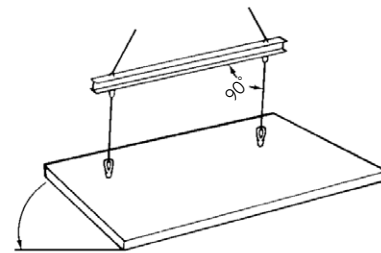

Right

4. Maneuvering from vertical to horizontal with face anchors

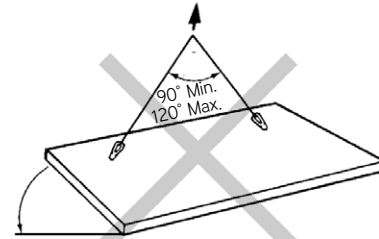

Wrong

P52 Swift Lift® Anchor

The P52 Swift Lift Anchor is hot forged from carbon steel. The formed head provides spherical seating that the Lifting Eye engages, while a disc-shaped foot is embedded in the concrete.

Due to its being a forged part, the Swift Lift Anchor does not depend on welds or thread engagement to develop its safe working load. Forging provides maximum safety with its advantageous material structure. This allows the anchor to easily meet the OSHA requirement of a 4 to 1 factor of safety.

In addition to the carbon steel anchors, Type 304 or 316 Stainless Steel Swift Lift Anchors are available on special order. Use stainless steel anchors when maximum protection against corrosion is required.

For safety, refer to the P52 Swift Lift Anchor Selection Table to determine the actual safe working load of an individual anchor. The MAXIMUM safe working load is clearly visible on the head of the anchor for easy recognition of the appropriate hardware and accessories for-use with each Swift Lift Anchor.

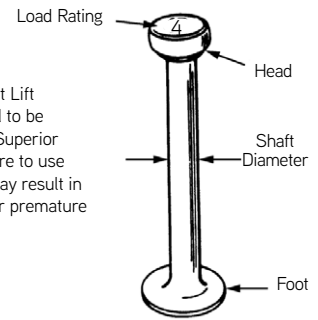

Caution: The Swift Lift Anchor is designed to be used with Dayton Superior components. Failure to use this combination may result in concrete spalling or premature failure.

To Order:

Specify: (1) quantity, (2) name, (3) system size, (4) length

Example:

200, P52 Swift Lift Anchors, 4 ton, 9-1/2" long

P52 Swift Lift Anchor and Recess Plug Dimensions

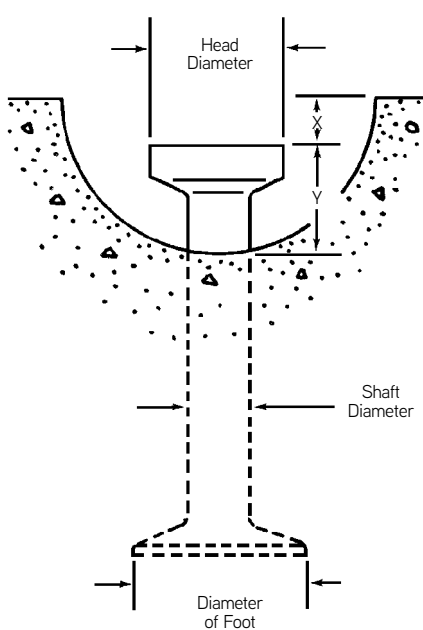

P52 Swift Lift Anchor

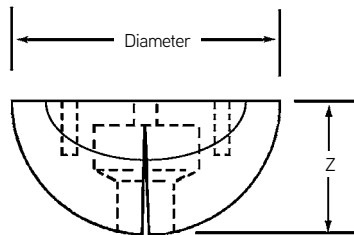

Swift Lift Round Recess Plug

Swift Lift Round Recess Plug Dimensions

Swift Lift Anchor	Diameter of Recess Plug	Dimension Z
1 Ton	2-7/16"	1-3/16"
2 Tons	3-5/16"	1-7/16"
4 Tons	4"	1-13/16"
8 Tons	5"	2-5/16"
20 Tons	6-3/8"	3-1/8"

Note: The diameter of the narrow recess plug is the same as the diameter of the round recess plug.

P52 Swift Lift Anchor Dimensions

Swift Lift Anchor	Dimension X	Dimension Y	Shaft Diameter	Foot Diameter	Head Diameter
1 Ton	5/16"	7/8"	3/8"	1"	11/16"
2 Tons	7/16"	1-1/16"	9/16"	1-3/8"	1-1/32"
4 Tons	9/16"	1-5/16"	3/4"	1-7/8"	1-11/32"
8 Tons	9/16"	1-5/8"	1-3/32"	2-5/8"	1-7/8"
20 Tons	9/16"	2-5/8"	1-1/2"	3-3/4"	2-3/4"

How to Install P56 and P56PL Recess Plugs on P52 Anchors

Grasp the recess plug firmly across the top diameter of the plug. Application of pressure by the thumb and fingers on the outer edge of the plug will cause the plug to open up to allow insertion of the anchor.

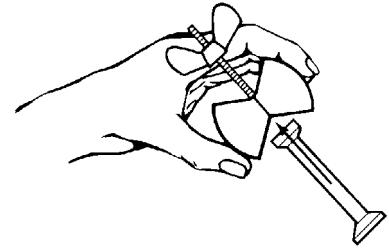

“Wet Setting” P52 Swift Lift Face Lift Anchors

When a Swift Lift anchor is to be positioned in the top surface of a flat precast section, wet setting the anchor is best done immediately after the concrete has been placed.

The anchor/recess plug assembly is attached to a small template board and pressed into the fresh concrete until the template board lies flush on the surface of the concrete.

Light vibration of the fresh concrete will assure proper embedment and anchorage.

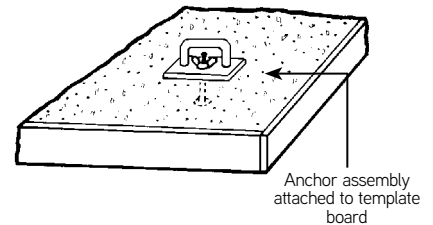

Recess Plug Removal

Swift Lift recess plugs provide two holes in the top surface that are used in the removal process. Insert two screw drivers or steel rods into the holes and simply lever the two across the plug for easy removal.

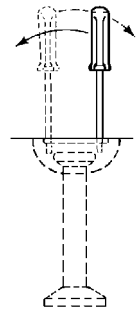

Selecting the Proper Swift Lift Anchor

Determination of the required rated load and length of a P52 Swift Lift Anchor is based on the actual maximum load that is transferred to the anchor. In most cases, a flat slab can be handled with the anchors properly located in the face of the flat slab. The anchors should normally be the maximum length that can be accommodated in the slab's structural thickness, allowing at least 1/2" clearance between the anchor and the casting bed. Dimension tables and safe working load charts, contained herein, will aid in the selection of the proper anchor. Keep in mind that the safe working load of an anchor is a function of several factors:

1. The effective concrete thickness
2. Actual edge distance
3. Concrete compressive strength at time of lift
4. Anchor length
5. In some applications, the use of a shear bar

P52 Swift Lift® Anchor Tensile and Shear Capacity

When anchors are used in the face of thin concrete elements

The following table lists the P52 Swift Lift Anchors that are currently manufactured. Other sizes and lengths are available on special order. However, the sizes and lengths of anchors shown will handle the majority of flat precast concrete elements.

When the P52 Swift Lift Anchor is properly embedded in normal weight concrete, the tabulated working loads are applicable for any direction of load. This applies even if the direction of load is parallel to the axis of the anchor, perpendicular to it or at any other angle.

Minimum distance between anchors is twice the minimum edge distance.

It is critical to remember that in order to obtain the safe working loads listed in the table below, the normal weight concrete must have obtained the minimum concrete strength shown, prior to initial load application.

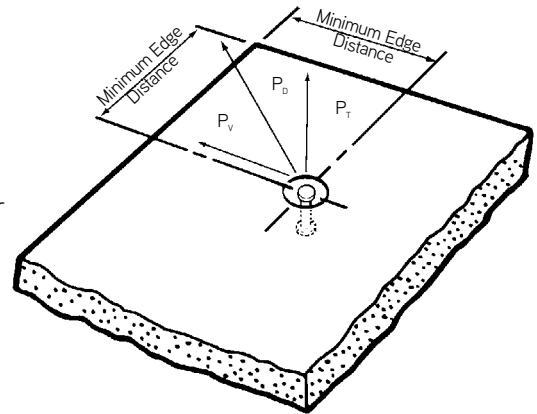

Swift Lift Anchor Ton x Length	Safe Working Load	Minimum Concrete Strength	Minimum Edge Distance
1 ton x 2-5/8"	1,700 lbs.	3,500 psi	8"
1 ton x 3-3/8"	2,000 lbs.	2,200 psi	10"
1 ton x 4-3/4"	2,000 lbs.	1,600 psi	10"
1 ton x 8"	2,000 lbs.	1,600 psi	10"
1 ton x 9-1/2"	2,000 lbs.	1,600 psi	10"
2 ton x 2-3/4"	2,100 lbs.	3,500 psi	8"
2 ton x 3-3/8"	2,900 lbs.	3,500 psi	10"
2 ton x 4-3/4"	4,000 lbs.	3,500 psi	10"
2 ton x 5-1/2"	4,000 lbs.	1,600 psi	13"
2 ton x 6"	4,000 lbs.	1,600 psi	13"
2 ton x 6-3/4"	4,000 lbs.	1,600 psi	13"
2 ton x 11"	4,000 lbs.	1,600 psi	14"
4 ton x 3-3/4"	4,000 lbs.	3,500 psi	12"
4 ton x 4-1/4"	4,900 lbs.	3,500 psi	13"
4 ton x 4-3/4"	5,800 lbs.	3,500 psi	14"
4 ton x 5-1/2"	7,400 lbs.	3,500 psi	17"
4 ton x 5-3/4"	7,900 lbs.	3,500 psi	17"
4 ton x 7-1/8"	8,000 lbs.	1,800 psi	20"
4 ton x 9-1/2"	8,000 lbs.	1,600 psi	17"
4 ton x 14"	8,000 lbs.	1,600 psi	18"
4 ton x 19"	8,000 lbs.	1,600 psi	20"
8 ton x 4-3/4"	6,400 lbs.	3,500 psi	16"
8 ton x 5-1/4"	6,850 lbs.	3,500 psi	16"
8 ton x 6-3/4"	11,200 lbs.	3,500 psi	21"
8 ton x 10"	16,000 lbs.	3,500 psi	19"
8 ton x 13-3/8"	16,000 lbs.	1,600 psi	23"
8 ton x 26-3/4"	16,000 lbs.	1,600 psi	27"
20 ton x 10"	25,000 lbs.	3,500 psi	24"
20 ton x 19-3/4"	40,000 lbs.	3,500 psi	31"

Safe Working Loads provide a factor of safety of approximately 4 to 1 in normal weight concrete. Safe Working Load is based on anchor setback from face of concrete "X" dimension, as shown on page 26.

P52W Swift Lift® Anchor

The P52W Swift Lift Anchors are the shortest 2-ton and 4-ton Swift Lift Anchors available and have been specially modified. A Type W Plain Washer is placed on the anchor's foot and welded in position. This modification has been made in order to increase the Safe Working Load of these short Swift Lift Anchors in thin precast concrete elements. Safe Working Load provides a factor of safety of approximately 4 to 1.

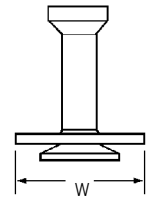

Swift Lift System

To Order:
Specify: (1) quantity, (2) name, (3) system size.

Example:
200, P52W Swift Lift Anchors, 2 ton.

Swift Lift Anchor Tons x Length	Safe Working Load	Minimum Concrete Strength	Minimum Thickness	W
2 tons x 2-3/4"	3,700 lbs.	3,500 psi	8"	2-1/2"
4 tons x 3-3/4"	5,700 lbs.	3,500 psi	12"	2-3/4"

P52 Swift Lift Anchors for Edge Lifting

The P52 Swift Lift Anchors and P51 Swift Lift Lifting Eyes are useful for raising precast concrete panels from their horizontal casting position to a vertical position for handling and shipping. When Swift Lift Anchors are used in thin precast panels and under shear loading conditions, a special shear bar must be used.

The applied shear load tends to bend the anchor, allowing the lifting eye to apply load to the thin concrete section above the recess plug. A properly installed shear bar captures the applied load and transfers it deeper into the concrete.

When raising precast panels from a horizontal position to a vertical position, always check both shear and tension safe working loads. In order to develop the anchor's shear safe working load, the minimum spacing between Swift Lift Anchors is two times the corner distance listed.

Note: Properly installed shear bars are required to develop Safe Working Loads shown. $2 \times d_e$ equals effective wall thickness for tensile loads.

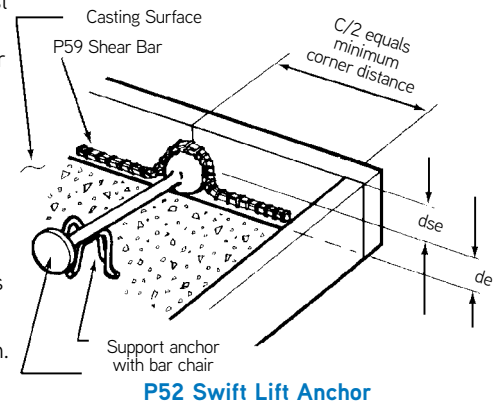

Note: See Shear Bar Table on page 30.

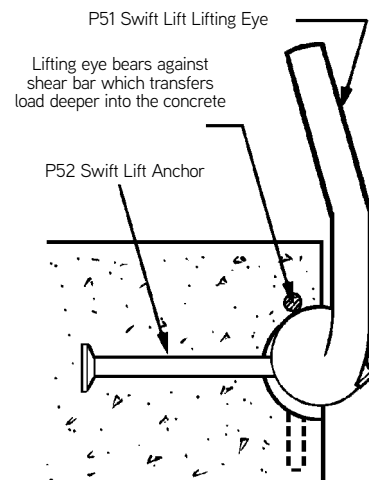
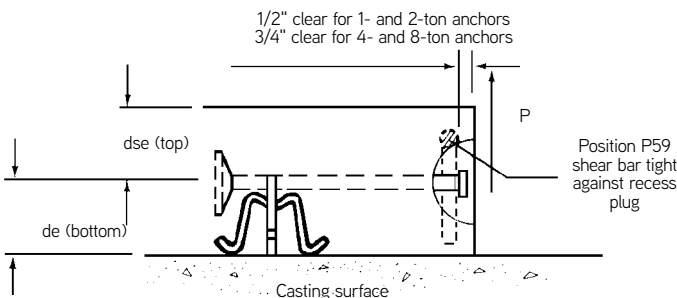

Section View of Swift Lift Assembly

P59 Swift Lift® Shear Bar P59 Swift Lift® Smooth Wire Shear Bar

Dayton Superior Swift Lift Shear Bars (P59) are utilized when edge lifting precast elements. The shear bar is secured tightly to the recess plug and at the time of lift helps to transfer the shear load deeper into the concrete. The P59 Smooth Wire Shear Bar is designed to snap into the built-in clips on the P54 recess plug. The standard shear bar is fabricated from rebar and must be securely wired tightly to the Swift Lift recess plugs.



**P59 Swift Lift Shear Bar
1-Ton and 8-Ton**

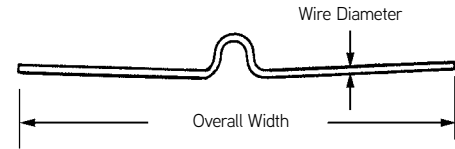

**P59 Swift Lift Smooth Wire Shear Bar
2-Ton and 4-Ton**

To Order:

Specify: (1) quantity, (2) name, (3) system size.

Example:

200, P59 Swift Lift Shear Bars, 4-Ton.

Anchor Safe Working Load	Shear Bar Type	Overall Width	Minimum Anchor Length	Wall Thickness	Minimum Corner Distance	Safe Working Load
1	Rebar	19"	4-3/4"	5'	15"	1,750 lbs.
1	Rebar	19"	4-3/4"	5-1/2"	16"	2,000 lbs.
1	Wire	19"	4-3/4"	6"	17"	2,000 lbs.
2	Wire	24"	6-3/4"	5'	15"	1,750 lbs.
2	Wire	24"	6-3/4"	5-1/2"	16"	2,200 lbs.
2	Wire	24"	6-3/4"	6"	17"	2,600 lbs.
2	Wire	24"	6-3/4"	7'	19"	2,700 lbs.
2	Wire	24"	6-3/4"	8"	21"	2,800 lbs.
4	Wire	30"	9-1/2"	5-1/2"	16"	2,100 lbs.
4	Wire	30"	9-1/2"	6"	17"	2,200 lbs.
4	Wire	30"	9-1/2"	7"	19"	2,600 lbs.
4	Wire	30"	9-1/2"	8"	21"	2,800 lbs.
8	Rebar	34"	13-3/8"	8"	19"	5,600 lbs.
8	Rebar	34"	13-3/8"	9"	21"	6,700 lbs.

Safe Working Load provides a factor of safety of approximately 4 to 1 in 4,500 psi normal weight concrete.

P59 Shear Bar Dimensions

Anchor Rated Load (Tons)	A	B	C	R	Rebar Size
1	7" 178 mm	5" 127 mm	2 1/2" 64 mm	1" 25 mm	#4 #10M
2	9" 229 mm	7" 178 mm	3" 76 mm	1 1/16" 37 mm	#4 #10M
4	10" 254 mm	9" 229 mm	3 3/4" 95 mm	1 3/4" 44 mm	#4 #10M
8	12" 305 mm	10" 254 mm	3 3/4" 95 mm	2 1/4" 57 mm	#6 #20M

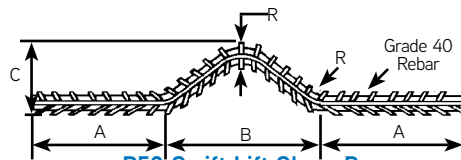

**P59 Swift Lift Shear Bar
1-Ton and 8-Ton**

P52 Swift Lift® Anchor in Thin Walls

The P52 Swift Lift Anchors, listed below, must be located the minimum distance away from a corner with the anchor foot being positioned at the center line of the wall. The anchor head location may be off center, however, any eccentricity of the foot will result in a reduction of the safe working load. When the anchor foot is not positioned at the center line of the wall, the effective wall thickness is equal to twice the actual edge distance.

To develop the safe working load of the P52 Swift Lift Anchor, the minimum spacing between two anchors is six times the anchor length.

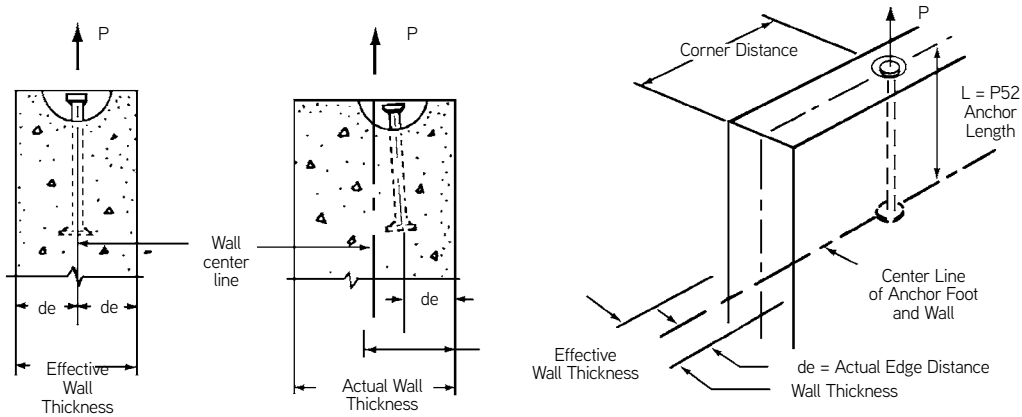

Swift Lift® Anchor Effective Tensile Capacity in Thin Walls

Swift Lift Anchor Ton x Length	Effective Wall Thickness 2 de	Actual Edge Distance de	Tensile Safe Working Load per Anchor Actual Corner Distance				
			6"	12"	18"	24"	30"
1 Ton x 4-3/4" Long	2-1/2"	1-1/4"	900 lbs.	1,100 lbs.	1,200 lbs.	1,200 lbs.	1,200 lbs.
	2-3/4"	1-3/8"	1,000 lbs.	1,200 lbs.	1,300 lbs.	1,300 lbs.	1,300 lbs.
	3"	1-1/2"	1,100 lbs.	1,300 lbs.	1,400 lbs.	1,400 lbs.	1,400 lbs.
	3-1/2"	1-3/4"	1,200 lbs.	1,600 lbs.	1,600 lbs.	1,600 lbs.	1,600 lbs.
	4"	2"	1,450 lbs.	1,800 lbs.	1,900 lbs.	1,900 lbs.	1,900 lbs.
	4-1/2"	2-1/4"	1,600 lbs.	2,000 lbs.	2,000 lbs.	2,000 lbs.	2,000 lbs.
1 Ton x 9-1/2" Long	2-1/2"	1-1/4"	1,300 lbs.	1,700 lbs.	1,900 lbs.	1,900 lbs.	1,900 lbs.
	2-3/4"	1-3/8"	1,400 lbs.	1,900 lbs.	2,000 lbs.	2,000 lbs.	2,000 lbs.
	3"	1-1/2"	1,500 lbs.	2,000 lbs.	2,000 lbs.	2,000 lbs.	2,000 lbs.
	3-1/2"	1-3/4"	1,800 lbs.	2,000 lbs.	2,000 lbs.	2,000 lbs.	2,000 lbs.
	4"	2"	2,000 lbs.	2,000 lbs.	2,000 lbs.	2,000 lbs.	2,000 lbs.
	4-1/2"	2-1/4"	2,000 lbs.	2,000 lbs.	2,000 lbs.	2,000 lbs.	2,000 lbs.

Safe Working Load provides a factor of safety of approximately 4 to 1 in 4,500 psi normal weight concrete.

Swift Lift® Anchor Effective Tensile Capacity in Thin Walls

Swift Lift System

Swift Lift Anchor Tons x Length	Effective Wall Thickness 2de	Actual Edge Distance de	Tensile Safe Working Load Per Anchor				
			Actual Corner Distance				
			8"	12"	18"	24"	30"
2 Tons x 6-3/4" Long	3"	1-1/2"	1,500 lbs.	1,700 lbs.	2,000 lbs.	2,000 lbs.	2,000 lbs.
	3-1/4"	1-5/8"	1,600 lbs.	1,900 lbs.	2,100 lbs.	2,200 lbs.	2,200 lbs.
	3-1/2"	1-3/4"	1,700 lbs.	2,000 lbs.	2,300 lbs.	2,300 lbs.	2,300 lbs.
	4"	2"	2,000 lbs.	2,300 lbs.	2,600 lbs.	2,700 lbs.	2,700 lbs.
	5"	2-1/2"	2,500 lbs.	2,900 lbs.	3,300 lbs.	3,400 lbs.	3,400 lbs.
	6"	3"	3,000 lbs.	3,500 lbs.	4,000 lbs.	4,000 lbs.	4,000 lbs.
2 Tons x 11" Long	3"	1-1/2"	1,900 lbs.	2,300 lbs.	2,700 lbs.	3,000 lbs.	3,200 lbs.
	3-1/4"	1-5/8"	2,100 lbs.	2,500 lbs.	3,000 lbs.	3,300 lbs.	3,500 lbs.
	3-1/2"	1-3/4"	2,200 lbs.	2,700 lbs.	3,200 lbs.	3,500 lbs.	3,700 lbs.
	4"	2"	2,500 lbs.	3,100 lbs.	3,700 lbs.	4,000 lbs.	4,000 lbs.
	5"	2-1/2"	3,200 lbs.	3,900 lbs.	4,000 lbs.	4,000 lbs.	4,000 lbs.
	6"	3"	3,800 lbs.	4,000 lbs.	4,000 lbs.	4,000 lbs.	4,000 lbs.

Safe Working Load provides a factor of safety of approximately 4 to 1 in 4,500 psi normal weight concrete.

Swift Lift Anchor Tons x Length	Effective Wall Thickness 2de	Actual Edge Distance de	Tensile Safe Working Load Per Anchor				
			Actual Corner Distance				
			10"	16"	24"	30"	42"
4 Tons x 9-1/2" Long	3-3/4"	1-7/8"	2,500 lbs.	3,000 lbs.	3,300 lbs.	3,400 lbs.	3,500 lbs.
	4"	2"	2,600 lbs.	3,200 lbs.	3,500 lbs.	3,700 lbs.	3,800 lbs.
	5"	2-1/2"	3,300 lbs.	4,000 lbs.	4,400 lbs.	4,600 lbs.	4,700 lbs.
	6"	3"	4,000 lbs.	4,800 lbs.	5,300 lbs.	5,500 lbs.	5,700 lbs.
	7"	3-1/2"	4,700 lbs.	5,600 lbs.	6,200 lbs.	6,500 lbs.	6,600 lbs.
	8"	4"	5,300 lbs.	6,400 lbs.	7,000 lbs.	7,400 lbs.	7,600 lbs.
4 Tons x 19" Long	3-3/4"	1-7/8"	3,500 lbs.	4,300 lbs.	4,900 lbs.	5,300 lbs.	5,800 lbs.
	4"	2"	3,800 lbs.	4,600 lbs.	5,300 lbs.	5,700 lbs.	6,200 lbs.
	5"	2-1/2"	4,700 lbs.	5,700 lbs.	6,600 lbs.	7,100 lbs.	7,800 lbs.
	6"	3"	5,700 lbs.	6,900 lbs.	7,900 lbs.	8,000 lbs.	8,000 lbs.
	7"	3-1/2"	6,600 lbs.	8,000 lbs.	8,000 lbs.	8,000 lbs.	8,000 lbs.
	8"	4"	7,600 lbs.	8,000 lbs.	8,000 lbs.	8,000 lbs.	8,000 lbs.

Safe Working Load provides a factor of safety of approximately 4 to 1 in 4,500 psi normal weight concrete.

Swift Lift® Anchor Effective Tensile Capacity in Thin Walls

Swift Lift Anchor Tons x Length	Effective Wall Thickness 2de	Actual Edge Distance de	Tensile Safe Working Load Per Anchor				
			Actual Corner Distance				
			12"	18"	24"	36"	45"
8 Tons x 13-3/8" Long	4-3/4"	2-3/8"	4,000 lbs.	4,800 lbs.	5,400 lbs.	6,000 lbs.	6,100 lbs.
	5"	2-1/2"	4,200 lbs.	5,100 lbs.	5,700 lbs.	6,300 lbs.	6,400 lbs.
	6"	3"	5,100 lbs.	6,100 lbs.	6,800 lbs.	7,500 lbs.	7,600 lbs.
	7"	3-1/2"	5,900 lbs.	7,100 lbs.	8,000 lbs.	8,800 lbs.	8,900 lbs.
	8"	4"	6,800 lbs.	8,100 lbs.	9,100 lbs.	10,100 lbs.	10,200 lbs.
	10"	5"	8,500 lbs.	10,200 lbs.	11,400 lbs.	12,600 lbs.	12,700 lbs.
	12"	6"	10,200 lbs.	12,200 lbs.	13,700 lbs.	15,100 lbs.	15,200 lbs.
8 Tons x 26-3/4" Long	4-3/4"	2-3/8"	5,800 lbs.	7,000 lbs.	8,000 lbs.	9,600 lbs.	11,200 lbs.
	5"	2-1/2"	6,100 lbs.	7,400 lbs.	8,500 lbs.	10,100 lbs.	11,800 lbs.
	6"	3"	7,300 lbs.	8,900 lbs.	9,500 lbs.	12,100 lbs.	14,100 lbs.
	7"	3-1/2"	8,500 lbs.	10,300 lbs.	11,800 lbs.	14,200 lbs.	16,000 lbs.
	8"	4"	9,700 lbs.	11,800 lbs.	13,500 lbs.	16,000 lbs.	16,000 lbs.
	10"	5"	12,100 lbs.	14,800 lbs.	16,000 lbs.	16,000 lbs.	16,000 lbs.
	12"	6"	14,500 lbs.	16,000 lbs.	16,000 lbs.	16,000 lbs.	16,000 lbs.

Safe Working Load provides a factor of safety of approximately 4 to 1 in 4,500 psi normal weight concrete.

Swift Lift Anchor Tons x Length	Effective Wall Thickness 2de	Actual Edge Distance de	Tensile Safe Working Load Per Anchor				
			Actual Corner Distance				
			10"	16"	24"	30"	42"
20 Tons x 19-3/4" Long	6-1/2"	3-1/4"	6,200 lbs.	7,500 lbs.	9,400 lbs.	10,300 lbs.	11,500 lbs.
	7"	3-1/2"	6,700 lbs.	8,100 lbs.	10,100 lbs.	11,100 lbs.	12,400 lbs.
	8"	4"	7,600 lbs.	8,900 lbs.	11,500 lbs.	12,600 lbs.	14,200 lbs.
	10"	5"	9,500 lbs.	11,600 lbs.	14,400 lbs.	15,800 lbs.	17,700 lbs.
	12"	6"	11,500 lbs.	14,000 lbs.	17,300 lbs.	19,000 lbs.	22,000 lbs.
	14"	7"	13,400 lbs.	16,300 lbs.	20,100 lbs.	22,100 lbs.	24,800 lbs.

Safe Working Load provides a factor of safety of approximately 4 to 1 in 4,500 psi normal weight concrete.

To recalculate the safe working load when the anchor is used in a lower strength concrete, multiply the tabulated Safe Working Load by the following reduction factors:

Concrete Strength	Reduction Factor
2,000 psi	.66
2,500 psi	.74
3,000 psi	.81
3,500 psi	.88
4,000 psi	.94
4,500 psi	1.00

Swift Lift® Anchor Effective Tensile Capacity

When anchors are used in groups and in thin walls

Swift Lift System

Swift Lift Anchor Tons x Length	Effective Wall Thickness 2de	Actual Edge Distance de	Tensile Safe Working Load Per Anchor				
			Actual Corner Distance				
			18"	24"	30"	36"	48"
2 Tons x 6-3/4" Long	3"	1-1/2"	1,200 lbs.	1,500 lbs.	1,800 lbs.	1,900 lbs.	2,000 lbs.
	3-1/4"	1-5/8"	1,300 lbs.	1,700 lbs.	1,900 lbs.	2,100 lbs.	2,200 lbs.
	3-1/2"	1-3/4"	1,400 lbs.	1,800 lbs.	2,100 lbs.	2,300 lbs.	2,400 lbs.
	4"	2"	1,600 lbs.	2,100 lbs.	2,400 lbs.	2,600 lbs.	2,700 lbs.
	5"	2-1/2"	2,000 lbs.	2,600 lbs.	3,000 lbs.	3,200 lbs.	3,400 lbs.
	6"	3"	2,500 lbs.	3,100 lbs.	3,600 lbs.	3,900 lbs.	4,000 lbs.
2 Tons x 11" Long	3"	1-1/2"	1,300 lbs.	1,700 lbs.	2,000 lbs.	2,300 lbs.	2,900 lbs.
	3-1/4"	1-5/8"	1,400 lbs.	1,800 lbs.	2,200 lbs.	2,500 lbs.	3,100 lbs.
	3-1/2"	1-3/4"	1,500 lbs.	1,900 lbs.	2,400 lbs.	2,700 lbs.	3,300 lbs.
	4"	2"	1,700 lbs.	2,200 lbs.	2,700 lbs.	3,100 lbs.	3,800 lbs.
	5"	2-1/2"	2,100 lbs.	2,800 lbs.	3,400 lbs.	3,900 lbs.	4,000 lbs.
	6"	3"	2,600 lbs.	3,400 lbs.	4,000 lbs.	4,000 lbs.	4,000 lbs.

Safe Working Load provides a factor of safety of approximately 4 to 1 in 4,500 psi normal weight concrete.

Swift Lift Anchor Tons x Length	Effective Wall Thickness 2de	Actual Edge Distance de	Tensile Safe Working Load Per Anchor				
			Actual Corner Distance				
			18"	24"	36"	48"	60"
4 Tons x 9-1/2" Long	3-3/4"	1-7/8"	1,600 lbs.	2,000 lbs.	2,800 lbs.	3,300 lbs.	3,500 lbs.
	4"	2"	1,700 lbs.	2,200 lbs.	3,000 lbs.	3,600 lbs.	3,800 lbs.
	5"	2-1/2"	2,100 lbs.	2,700 lbs.	3,800 lbs.	4,500 lbs.	4,700 lbs.
	6"	3"	2,500 lbs.	3,300 lbs.	4,600 lbs.	5,400 lbs.	5,700 lbs.
	7"	3-1/2"	3,000 lbs.	3,900 lbs.	5,300 lbs.	6,300 lbs.	6,700 lbs.
	8"	4"	3,400 lbs.	4,400 lbs.	6,100 lbs.	7,200 lbs.	7,600 lbs.
4 Tons x 19" Long	3-3/4"	1-7/8"	1,600 lbs.	2,200 lbs.	3,200 lbs.	4,100 lbs.	5,000 lbs.
	4"	2"	1,700 lbs.	2,300 lbs.	3,400 lbs.	4,400 lbs.	5,300 lbs.
	5"	2-1/2"	2,200 lbs.	2,900 lbs.	4,300 lbs.	5,500 lbs.	6,600 lbs.
	6"	3"	2,600 lbs.	3,500 lbs.	5,100 lbs.	6,600 lbs.	8,000 lbs.
	7"	3-1/2"	3,100 lbs.	4,100 lbs.	6,000 lbs.	7,700 lbs.	8,000 lbs.
	8"	4"	3,500 lbs.	4,500 lbs.	6,800 lbs.	8,000 lbs.	8,000 lbs.

Safe Working Load provides a factor of safety of approximately 4 to 1 in 4,500 psi normal weight concrete.

Swift Lift® Anchor Effective Tensile Capacity

When anchors are used in groups and in thin walls

Swift Lift Anchor Tons x Length	Effective Wall Thickness 2de	Actual Edge Distance de	Tensile Safe Working Load Per Anchor				
			Actual Corner Distance				
			12"	18"	24"	36"	45"
8 Tons x 13-3/8" Long	4-3/4"	2-3/8"	2,800 lbs.	3,600 lbs.	4,800 lbs.	5,300 lbs.	5,300 lbs.
	5"	2-1/2"	2,900 lbs.	3,800 lbs.	5,000 lbs.	5,600 lbs.	5,600 lbs.
	6"	3"	3,500 lbs.	4,500 lbs.	6,000 lbs.	6,700 lbs.	6,700 lbs.
	7"	3-1/2"	4,100 lbs.	5,300 lbs.	7,100 lbs.	7,800 lbs.	7,800 lbs.
	8"	4"	4,700 lbs.	6,000 lbs.	8,100 lbs.	8,900 lbs.	8,900 lbs.
	10"	5"	5,900 lbs.	7,500 lbs.	10,100 lbs.	11,200 lbs.	11,200 lbs.
8 Tons x 26-3/4" Long	4-3/4"	2-3/8"	2,900 lbs.	3,800 lbs.	5,600 lbs.	7,200 lbs.	8,500 lbs.
	5"	2-1/2"	3,100 lbs.	4,000 lbs.	5,900 lbs.	7,600 lbs.	9,000 lbs.
	6"	3"	3,700 lbs.	4,800 lbs.	7,100 lbs.	9,100 lbs.	10,800 lbs.
	7"	3-1/2"	4,300 lbs.	5,700 lbs.	8,300 lbs.	10,600 lbs.	12,500 lbs.
	8"	4"	4,900 lbs.	6,500 lbs.	9,400 lbs.	12,100 lbs.	14,300 lbs.
	10"	5"	6,100 lbs.	8,100 lbs.	11,800 lbs.	15,100 lbs.	16,000 lbs.
12"	5-1/2"	6,700 lbs.	8,900 lbs.	13,000 lbs.	16,000 lbs.	16,000 lbs.	

Safe Working Load provides a factor of safety of approximately 4 to 1 in 4,500 psi normal weight concrete.

Swift Lift Anchor Tons x Length	Effective Wall Thickness 2de	Actual Edge Distance de	Tensile Safe Working Load Per Anchor				
			Actual Corner Distance				
			10"	16"	24"	30"	42"
20 Tons x 19-3/4" Long	6-1/2"	3-1/4"	4,300 lbs.	5,200 lbs.	6,800 lbs.	8,300 lbs.	10,200 lbs.
	7"	3-1/2"	4,700 lbs.	5,600 lbs.	7,400 lbs.	8,900 lbs.	11,000 lbs.
	8"	4"	5,400 lbs.	6,300 lbs.	8,400 lbs.	10,200 lbs.	12,600 lbs.
	10"	5"	6,700 lbs.	7,900 lbs.	10,500 lbs.	12,700 lbs.	15,700 lbs.
	12"	6"	8,000 lbs.	9,500 lbs.	12,600 lbs.	15,300 lbs.	18,900 lbs.
	14"	7"	9,300 lbs.	11,100 lbs.	14,700 lbs.	17,800 lbs.	22,000 lbs.

Safe Working Load provides a factor of safety of approximately 4 to 1 in 4,500 psi normal weight concrete.

To recalculate the safe working load when the anchor is used in a lower strength concrete, multiply the tabulated Safe Working Load by the following reduction factors:

Concrete Strength	Reduction Factor
2,000 psi	.66
2,500 psi	.74
3,000 psi	.81
3,500 psi	.88
4,000 psi	.94
4,500 psi	1.00

P53 Swift Lift® Eye Anchor

Use with P60 Tension Bar

The Dayton Superior Swift Lift Eye Anchor (P53) is similar to the P52 anchor but has an eye at the foot to accept P60 Tension Bars. The P53 anchor is used primarily in thin sections, thin panels of lightweight concrete or shapes that must be handled at concrete compressive strengths below 2,000 psi. P53 anchors are available in 1, 2, 4, 8 and 20-ton capacities and each has its load rating embossed on the head.

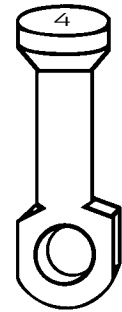

P53 Swift Lift Eye Anchor

To Order:

Specify: (1) quantity, (2) name, (3) system size, (4) length.

Example:

200, P53 Swift Lift Eye Anchors, 4 ton, 9-1/2" long.

P53 Swift Lift Eye Anchor for Lifting and Handling

The P53 Swift Lift Eye Anchor is designed for use with the P60 Tension Bar placed through the eye of the anchor. This combination of Swift Lift Eye Anchor and P60 Tension Bar allows the anchor's full rated tensile load to be developed in thin, narrow wall applications. The anchor should be located at the center line of the wall. When two or more anchors are required, the minimum spacing between anchors must be equal to the minimum panel width.

The combination of P53 Swift Lift Eye Anchor and P60 Tension Bar is an excellent system to use for lifting, handling and setting precast columns.

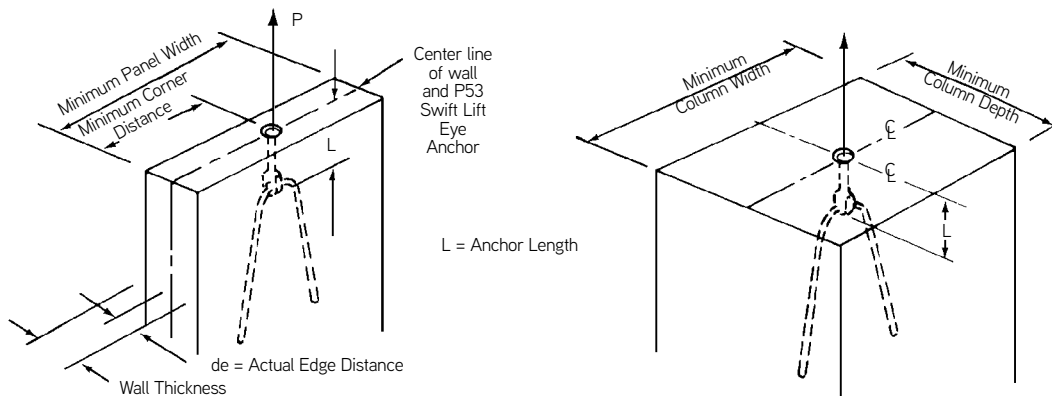

P53 Swift Lift Eye Anchor Selection Table

Anchor Rated Load (tons)	Anchor Length L	Minimum Thickness or Depth de	Actual Edge Distance de	Minimum Corner Distance	Minimum Panel Width	Tensile Safe Working Load per Anchor* (lbs.)
1	2-1/2"	3"	1-1/2"	8"	16"	2,000
2	3-1/2"	3"	1-1/2"	4"	8"	4,000
4	4-3/4"	3-3/4"	1-7/8"	5"	10"	8,000
8	7-1/16"	4-3/4"	2-3/8"	7"	14"	16,000
20	9-7/8"	6-3/8"	3-3/16"	8-1/2"	17"	40,000

* Safe Working Load provides a factor of safety of approximately 4 to 1 in 2,000 psi normal weight concrete. The P53 Eye Anchor must be used in conjunction with the P60 Tension Bar in order to develop its published rated working loads.

Note: Contact Dayton Superior Technical Service Department for safe working loads when the P53 Eye Anchor is used with straight lengths of rebar.

P60 Swift Lift® Tension Bar

For use with P53

The Dayton Superior Swift Lift Tension Bar (P60) is designed to be used with the P53 Eye Anchor in order for the eye anchor to develop its published rated working loads. See P60 sizes and dimensions below.

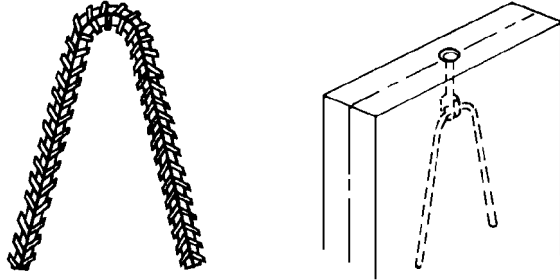

To Order:

Specify: (1) quantity, (2) name, (3) anchor size.

Example:

200, P60 Swift Lift Tension Bar, 10-ton anchor.

P60 Swift Lift Tension Bar

P60 Swift Lift Tension Bar Dimensions

Anchor Rated Load (Tons)	Grade 60 Rebar Size	Rebar Overall Length	A		R
			Standard	Maximum	
1	.306" Wire	40"	14 "	—	3/4"
2	#3	24"	5 "	7 -1/2 "	1-1/8"
4	#5	24"	6 -1/4 "	10 "	1-7/8"
8	#6	48"	9 -1/2 "	15 "	2-1/4"
20	#9	156"	12 -1/2 "	20 "	3"

Note: Wire style is for use with 1 ton P53 Eye Anchors only.

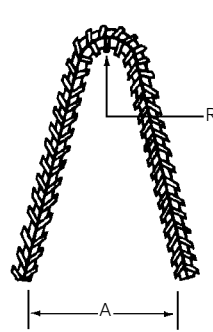

P60 Rebar Style

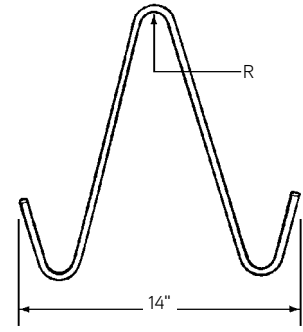

P60 Wire Style

P60 Swift Lift® Tension Bar Installation

The proper installation of a tension bar is as follows:

1. Place the tension bar through the eye of the anchor in such a manner that the tension bar contacts the bottom of the eye.
2. Make certain the legs of the tension bar are equal on either side of the anchor.
3. Wire the tension bar into position so that the tension bar stays in contact with the bottom of the eye. (See sketch below.)

DO NOT attempt to use field-bent bars as a replacement for the Dayton Superior P60 Tension Bar. Field bending may result in an improperly shaped tension bar, an incorrect radius and/or a cracked bar. A problem such as this can cause the field-bent tension bar to fail prematurely.

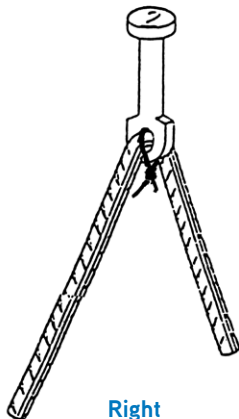

Right

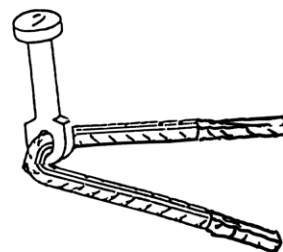

Wrong

P54 Swift Lift® Throw-Away Recess Plug

The Dayton Superior P54 Recess Plug is fabricated from high-density polyethylene plastic in two sizes (2-ton and 4-ton) to accommodate the P52 Swift Lift Anchor. The two-piece design snaps together around the head of the anchor to securely grasp the anchor. Tabs on the recess plug provide a convenient method to nail the assembly to the form. Built-in retainers allow a P59 Shear Bar to clip to the recess plug and be held in correct position. The P54 recess plug is designed to properly position the anchor below the surface of the concrete. This allows easy patching of the recess and prevents surface staining from exposed steel.

Warning: The P54 recess plug is designed to be used with the P52 insert and P59 shear bar combination. Failure to use these components in this combination may result in concrete spalling and/or premature failure.

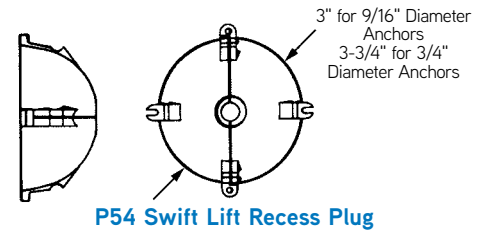

To Order:
Specify: (1) quantity, (2) name, (3) anchor size.

Example:
200, P54 Swift Lift Recess Plugs, 4-ton anchor.

- Assemble the P54 Recess Plug by placing the head of the P52 Swift-Lift Anchor inside two halves of the recess plug. Then snap the two halves together. It is very difficult to assemble the unit with the foot of the anchor inside the P54 Recess Plug and still get the two halves to close together correctly. If the two halves of the P54 Recess Plug do not fit closely together, it could be because the anchor is in upside down. In such a case, reverse the anchor and try again.

- A correctly assembled P54 Recess Plug and P52 Swift Lift Anchor.

- Attach the assembled P54 Recess Plug and anchor to the form work in its predetermined location with the recess plug seam in the vertical position. Use common (not double headed) nails in the upper three tabs of the recess plug. The plug and anchor assembly can also be attached to the form work by using a 2-ton stud and wingnut if desired. Provide bar supports around the anchor, as shown, to prevent displacement during the casting process.

- Slip the preformed shear bar on the P54 Recess Plug, as shown. The receiving tabs of the P54 Recess Plug will correctly position the shear bar. Usually, additional support wiring is not needed to hold the shear bar in place. However, prudent users will provide an additional wire tie or two, to make certain the shear bar will not dislodge during concrete placement. Wire tie the P52 Swift-Lift Anchor to reinforcing steel, as shown.

P56 Swift Lift® Narrow Recess Plug

The Dayton Superior P56 Swift Lift Narrow Recess Plug is designed for use in thin-wall conditions, such as the top edge of highway safety barriers. The recess plug is bolted to the form using a P63 stud and P64 wing nut combination and it correctly positions the anchor below the surface of the concrete. P56 recess plugs are fabricated from nitrile butadiene and are ideal for conditions requiring temperature or oil resistance.

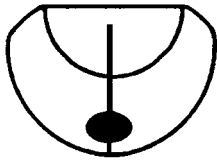

P56 Swift Lift Narrow Recess Plug

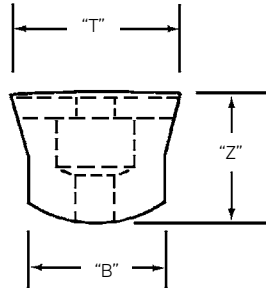

P56 Swift Lift Narrow Recess Plug

To Order:

Specify: (1) quantity, (2) name, (3) anchor size.

Example:

200, P56 Swift Lift Narrow Recess Plugs, 4-ton anchor.

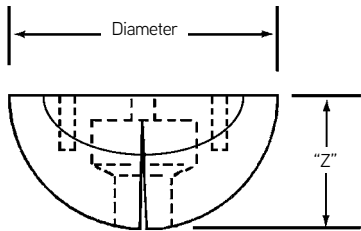

P56 Swift Lift Narrow Recess Dimensions

Swift Lift Anchor	Diameter of Recess Plug	Dimension "Z"	Dimension "T"	Dimension "B"
1	2-3/8"	1-3/16"	1-21/32"	1-11/32"
2	3"	1-7/16"	2-1/32"	1-23/32"
4	3-3/4"	1-13/16"	2-3/4"	2-9/32"
8	4-3/4"	2-5/16"	3-11/32"	2-15/16"
20	6-3/8"	3-1/8"	4-15/16"	4-7/16"

Note: The diameter of the narrow recess plug is the same as the diameter of the round recess plug.

P56R Swift Lift® Round Recess Plug

The Dayton Superior P56R Swift Lift Round Recess Plug is fabricated from nitrile butadiene and ideal for use in conditions requiring temperature or oil resistance. The plug must use the P63R Attachment Stud and P66R Attachment Nut. This plug can not be attached to the form with either a Holding Plate or Magnetic Setting Plate. Dimensions of the recess plug are slightly smaller than the standard P56 PL urethane plug. This recess is available by special order.

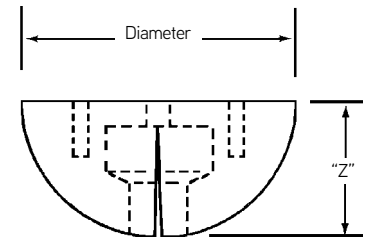

Swift Lift Round Recess Plug Dimensions

Swift Lift Anchor	Diameter of Recess Plug	Depth "Z"
1	2.375	1.188
2	2.918	1.514
4	3.661	1.875
8	4.659	2.375
20 Tons	6.375	3.063

Note: The diameter of the narrow recess plug is the same as the diameter of the round recess plug.

P56PL Swift Lift® Plus Recess Plug

The Dayton Superior P56PL Swift Lift Plus Recess Plug is manufactured from high-grade elastomeric, thermal set urethane to provide improved tear, heat and chemical resistance. The versatile, reusable plug utilizes a variety of accessories to provide installation and stripping ease in many different applications. P56PL recess plugs are available for 1, 2, 4 and 8-ton system sizes. See dimensions of P56PL Recess Plug in P52 information.

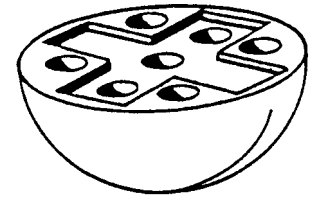

P56PL Swift Lift Plus Recess Plug

P57 Swift Lift® Steel Recess Plug

To Order:

Specify: (1) quantity, (2) name, (3) anchor size.

Example:

200, P54PL Swift Lift Plus Recess Plugs, 4-Ton anchor.

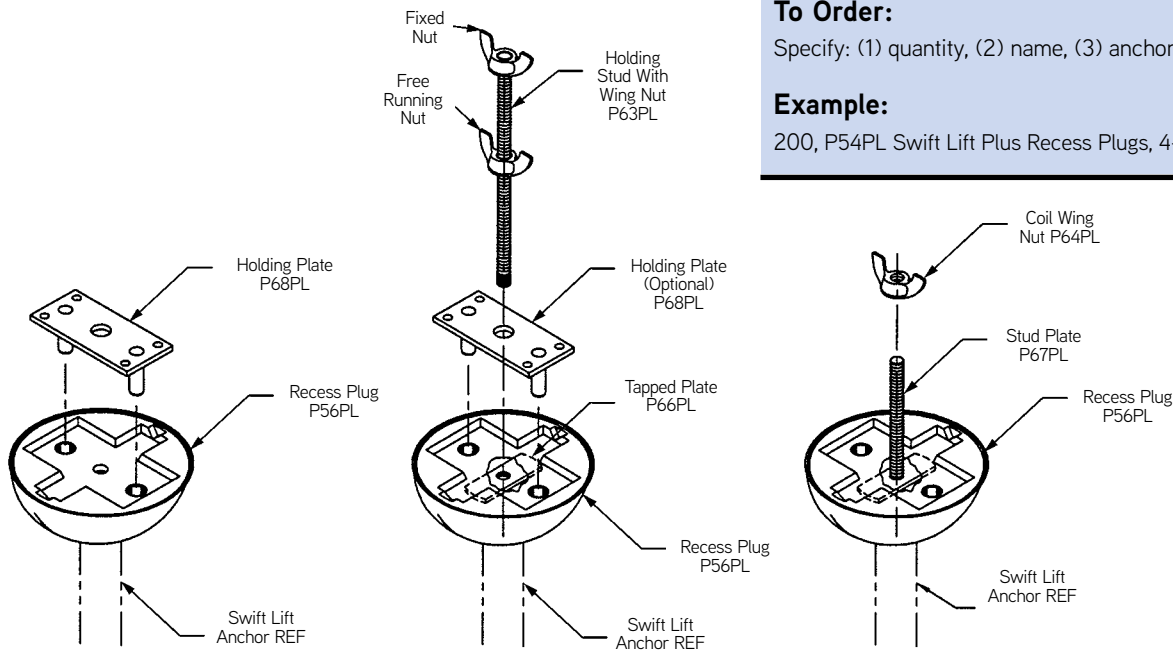

P56PL Swift Lift Plus Recess Plug Typical Installations

P58 Swift Lift® Rubber Ring

The Dayton Superior P57 Swift Lift Steel Recess Plug is designed for permanent or semi-permanent attachment to repetitive-use precast forms, such as battery molds, steel forms that have a collapsible stripping feature, etc. The recess plug is drilled and tapped for easy attachment to the form or may be held in place by a magnetic plate, tack welded or glued. Available in 1, 2 and 4-ton only.

The P58 Swift Lift Rubber Ring is placed on the shaft of the anchor and seats in the recess plug to hold the anchor firmly in the recess plug. It is recommended that when the P57 recess plug is used, the anchor end be supported to prevent dislodging (See sketch below).



P57 Swift Lift Steel Recess Plug

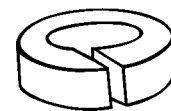

P58 Swift Lift Rubber Ring for Steel Recess Plug

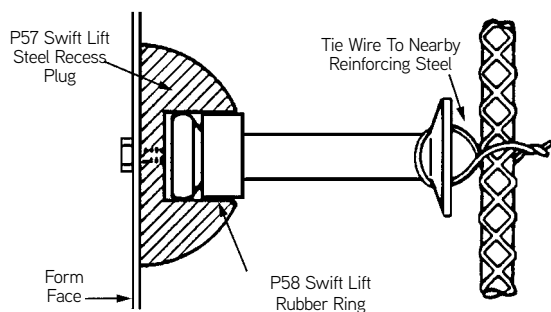

To Order:

Specify: (1) quantity, (2) name, (3) anchor size.

Example:

200, P57 Swift Lift Steel Recess Plugs, 4-Ton anchor and 400 P58 Swift Lift Rubber Rings for 4-Ton anchors.

P61 Swift Lift® Setting Plate, P62 Countersunk Screw

The Dayton Superior P61 Swift Lift Setting Plate and P62 Countersunk Screw combination provide an easy method of placing a Swift Lift Anchor into the surface of a flat panel without obstructing the screeding process. The P61 setting plate is available in two sizes, a 4" unit for use with 4-ton anchors and a 5" unit for use with 8-ton anchors. The P62 screw is available in two sizes to match the setting plates. The 4-ton setup uses a 3/4" long, 5/16" – 18 NC thread screw and the 8-ton setup uses a 3/4" long, 7/16" – 14 NC thread screw.

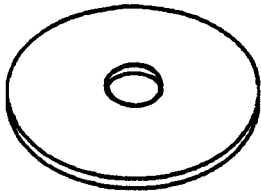
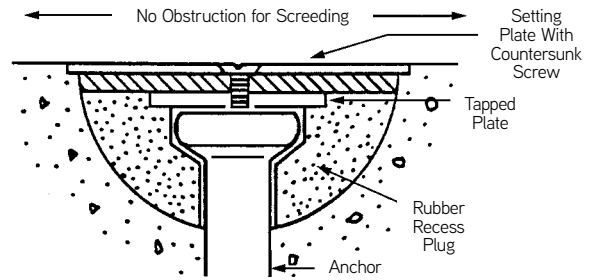

P61 Swift Lift Setting Plate



P62 Swift Lift Countersunk Screw

To Order:

Specify: (1) quantity, (2) name, (3) anchor size.

Example:

200, P61 Swift Lift Setting Plates and 200, P62 Countersunk Screws for 4-ton anchors.

P63 Swift Lift® Stud, P64 Swift Lift Wing Nut

The Dayton Superior P63 Swift Lift Stud and P64 Wing Nut combination is used to set P56 Narrow Recess Plugs. Available in two sizes, 5/16" – 18 NC threads for use with the 1-ton anchor and 7/16" – 14 NC threads for use with 2, 4, 8 and 20-ton P56 anchors.

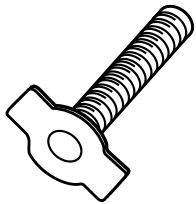

P63 Swift Lift Stud

Note: The P63 Stud and P64 Wing Nut are not interchangeable with the P56PL Recess Plug accessories.

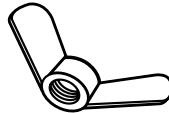

P64 Swift Lift Wing Nut

To Order:

Specify: (1) quantity, (2) name, (3) size.

Example:

200, P63 Swift Lift Studs and 200 P64 Swift Lift Wing Nuts, 7/16" dia.

P63PL Swift Lift® Plus Holding Stud, P64PL Swift Lift Plus Wing Nut

The Dayton Superior P63PL Swift Lift Plus Holding Stud is a 3/8" diameter, coil threaded stud with a fixed wing nut and a free-running wing nut used with the P66PL threaded plate to quickly attach the P56PL recess plug to the formwork. The holding stud is inserted through the form and threaded into the threaded plate. Complete the anchor installation by screwing the free-running wing nut tightly against the form.

The P64PL Wing Nut has 3/8" diameter coil thread and is available as a replacement nut for the P63PL Holding Stud.

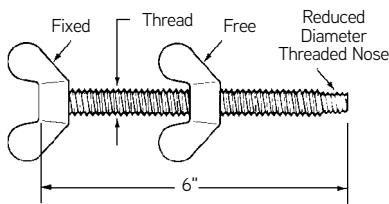

P63PL Swift Lift Plus Holding Stud

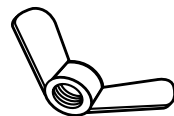

P64PL Swift Lift Plus Wing Nut

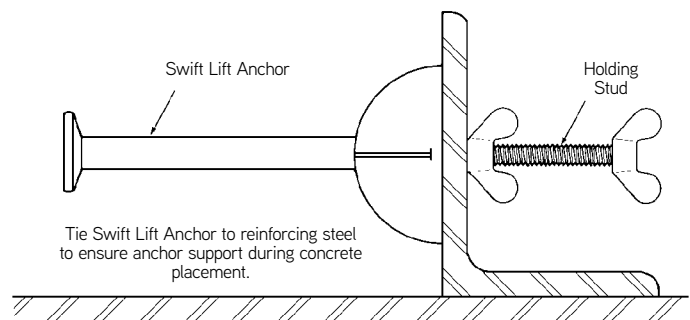

To Order:

Specify: (1) quantity, (2) name.

Example:

200, P63PL Swift Lift Plus Holding Studs.

P66 Swift Lift® Tapped Plate

The Dayton Superior Swift Lift Tapped Plate (P66) is tapped for either a 5/16" or 7/16" diameter NC thread and used to install the P56 Narrow Recess Plug. This is a replacement plate only; it can be used with the P63 Stud or with NC bolts supplied by others.

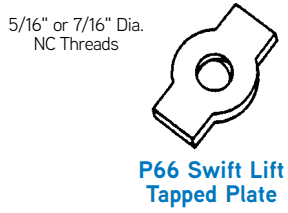

To Order:
Specify: (1) quantity, (2) name, (3) thread size.

Example:
100, P66 Swift Lift Tapped Plate, 7/16" dia. NC thread.

P66PL Swift Lift® Plus Threaded Plate P67PL Swift Lift® Plus Stud Plate P68PL Swift Lift® Plus Holding Plate

The Dayton Superior P66PL Swift Lift Plus Threaded Plate, P67PL Stud Plate and P68PL Holding Plate are working parts used to install the P56PL Recess Plug in various applications. These working parts are available in 1, 2, 4 and 8-ton system sizes.

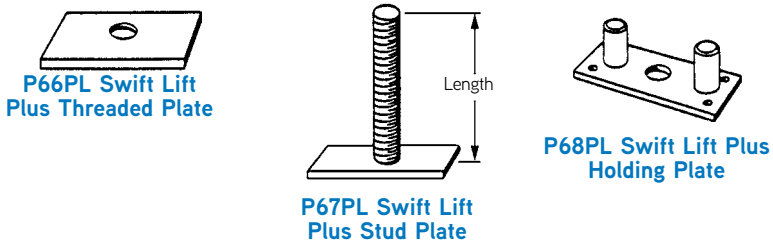

To Order:
Specify: (1) quantity, (2) name, (3) system size.

Example:
100, P66PL Swift Lift Plus Threaded Plate, 4-ton system.

P69 Swift Lift® Magnetic Setting Plate

The Dayton Superior P69 Swift Lift Magnetic Setting Plates are available to firmly set P56PL Recess Plugs in metal, precast concrete forms. The reusable magnetic setting plate eliminates holes drilled in the metal forms for anchor setting purposes.

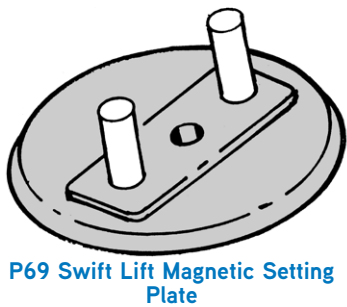

NOTE: One piece recess plug with magnets imbedded in top available, contact DSC Customer Service.

To Order:
Specify: (1) quantity, (2) name, (3) system size.

Example:
20, P69 Swift Lift Magnetic Setting Plates, 4-ton system.

P104S Magnetic One Piece Swift Lift® Recess

The Dayton Superior P104S Magnetic OnePiece Swift Lift Recess is a urethane recess plug with magnets embedded in the face for easy attachment to metal forms. This provides the precaster the option for a one-piece unit versus P56PL Swift Lift Recess Plug and P69 Magnetic Setting Plate. It is available in 2, 4 and 8-ton sizes.

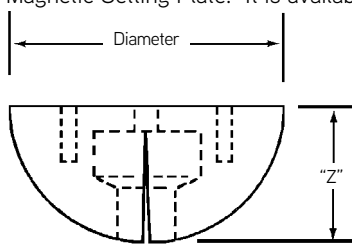

To Order:
Specify: (1) quantity, (2) name, (3) system size.

Example:
20, P104 Magnetic OnePiece Swift Lift Magnetic Recess, 8-ton system.

Fleet-Lift™ System Overview

The Dayton Superior Fleet-Lift System comprises two main parts, the Fleet-Lift Anchor and the Fleet-Lift Ring Clutch. The design of the system allows loads to be applied from any direction.

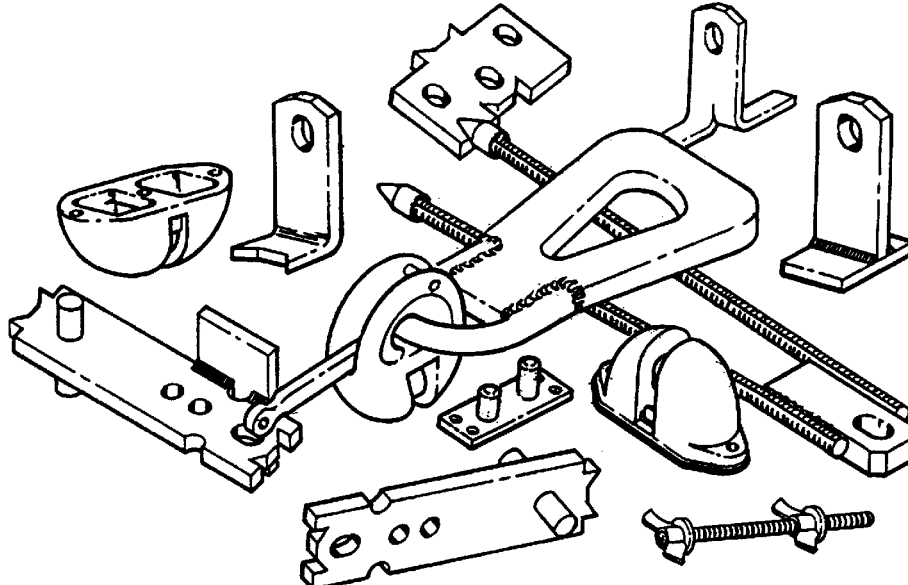

Fleet-Lift System Components

Fleet-Lift System

The selection of the proper capacity Fleet-Lift System is based on several factors, such as:

- Size of precast element
- Rigging configuration
- Compressive strength of concrete at initial lift
- Embedment depth of anchor
- Edge distance
- Anchor spacing
- Direction of applied load
- Use of tension bars, shear bars or shear plates.

Each Fleet-Lift anchor is stamped with its MAXIMUM safe working load and the letters DSC, which identifies it as a Dayton Superior Corporation product. The hole near the top of the anchor head is designed to receive the appropriate size ring clutch.

Both the anchor and ring clutch are rated with a safe working load. The safe working load of the anchor is based on a factor of safety of 4 to 1 (ultimate to safe). Each ring clutch has a Load Range embossed on it, which shows the anchors it can be used with. A factor of safety of 5 to 1 is applied to the highest load in the range for each size of ring clutch.

To use, simply push the ring clutch onto the head of the anchor that is located in a recess created by a Fleet-Lift recess plug. Once the ring clutch is pushed onto the head of the anchor, the ring clutch's curved bolt is pushed through the hole in the anchor. This locks the ring clutch and anchor into a single unit ready to lift the precast concrete element.

To disengage the anchor and ring clutch, simply pull the curved bolt free of the anchor. This allows the ring clutch to be easily removed from the head of the anchor.

Dayton Superior recommends a minimum 3/4" cover between the bottom of an anchor and the concrete surface. This minimum recommended concrete cover is to prevent anchor corrosion.

P91S Fleet-Lift Ring Clutch

The P91S Fleet-Lift Ring Clutch consists of a clutch body, a curved bolt and a high strength bail. Installation and release is safe and simple. After the clutch is inserted over the anchor head and into the recess, the curved bolt is rotated into the closed position.

Rotation of the standard bail is a full 360°. Once engaged and supporting four hundred pounds of load, the ring clutch cannot be released.

To Order:

Specify: (1) quantity, (2) name, (3) product code, (4) system size.

Example:

9, P91S Fleet-Lift Ring Clutches, FL002S, 4/6-ton units.

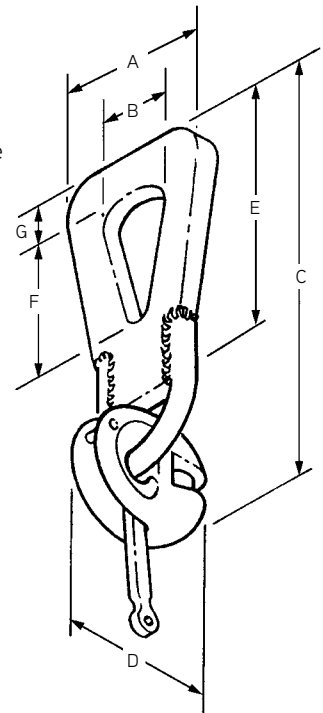

P91S Fleet-Lift Ring Clutch Selection Table

Safe Working Load (Tons)	Load Range (Tons)	Product Code	A	B	C	D	E	F	G
3	2-3	FL001S	3-3/4"	2-3/8"	10-1/2"	3"	7"	3"	1"
6	4-6	FL002S	4-3/4"	2-5/8"	12-1/2"	4"	8-1/4"	3-1/2"	1-1/2"
12	8-12	FL003S	5-7/8"	3"	17-3/4"	5-7/8"	11"	4-1/2"	2-1/8"

Safe Working Load provides a factor of safety of approximately 5 to 1.

P91S Fleet-Lift Ring Clutch

Installation of P91S Ring Clutch

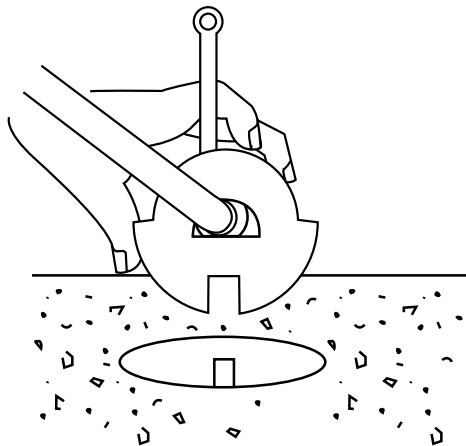

The P91S Ring Clutch is located directly over the head of a Fleet-Lift Anchor.

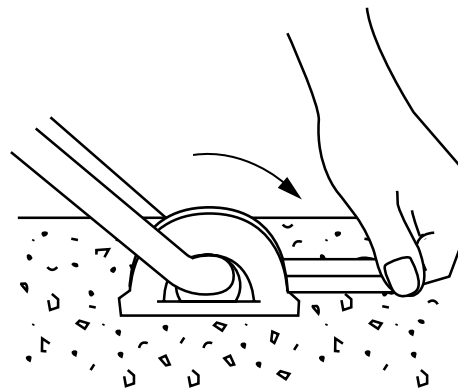

The ring clutch is pushed down onto the anchor head and the curved bolt is rotated through the engagement hole of the anchor and locked into position. The process of engaging anchor and ring clutch is completed in seconds.

Fleet-Lift System

P91NC Fleet-Lift Cable Bail Ring Clutch

The Fleet-Lift Ring Clutch with cable bail can be the solution to many difficult lifting and rotating-to-vertical situations. Cable bails can also be used to replace bent or damaged bails on standard clutches.

The engagement, use and release of the Cable Bail Ring Clutch are similar in operation to the standard Ring Clutch with the fixed bail.

Once the load is relaxed, the ring clutch can be easily released.

P91NC Fleet-Lift Cable Bail Ring Clutch Selection Table

Safe Working Load (Tons)	Load Range (Tons)	Product Code	A	B	C	D	E
3	2-3	FL001NC	30"	9/16"	2-3/4"	2-3/8"	4-3/8"
6	4-6	FL002NC	36"	3/4"	3-11/16"	3-3/8"	6-5/8"
10	8-10	FL003NC	48"	1"	5-5/16"	3-3/4"	7-1/8"

Safe working load provides a factor of safety of approximately 5 to 1.

To Order:

Specify: (1) quantity, (2) name, (3) product code, (4) system size.

Example:

9, P91NC Fleet-Lift Cable Bail Ring Clutches, FL002NC, 4/6-ton units.

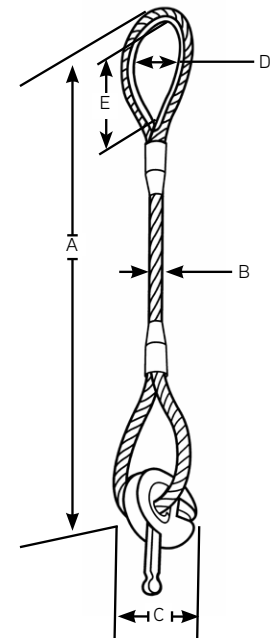

P91NC Fleet-Lift Cable Bail Ring Clutch

Fleet-Lift System

Inspection and Maintenance of Ring Clutches

The Fleet-Lift P91S and P91NC Ring Clutches may be subject to wear, misuse, overloading and many other factors that may affect a Ring Clutch's safe working load.

The users must establish a program for inspection of their Ring Clutches based on their frequency of use. Inspections should consist of the following:

1. Determine the general overall condition and wear.
2. Make certain the bail can rotate freely in all directions.
3. If evidence of heat application is found, the clutch must be destroyed.
4. Check for bent or twisted bails.
5. Check for worn or bent curved bolt.
6. Check for worn or deformed main clutch body.
7. Check for enlarged engagement slot.

During inspection of the clutch body, if the engagement slot is found to exceed dimension W, remove the ring clutch from service and destroy it.

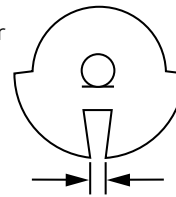

Safe Working Load (Tons)	Load Range (Tons)	W
3	2-3	0.562"
6	4-6	0.781"
10	8-10	0.921"

Note: Destroy all units if found to be worn, damaged, bent or twisted. The proper method for use in destroying a Ring Clutch is to cut off and remove the bail. No repair or welding on Fleet-Lift Ring Clutches is permitted.

Additional Inspection of Cable Bails

Before every use, inspect the wire cable for:

1. Damage or extreme wear
2. Bends or kinks
3. Fraying or loosening of outer strands
4. Squeezes in the free length
5. Squeezes in the support area
6. Cable swelling
7. Cable ruptures in excess of four runners in three diameters of the cable length, six runners in six diameters of the cable length or sixteen runners in 30 diameters of cable length.

If the cable is damaged, it must be replaced. Dayton Superior can arrange for cable replacement. Contact the nearest Dayton Superior Technical Assistance for information and cost.

P92 Fleet-Lift Erection Anchor

Fleet-Lift P92 Erection Anchors are specifically designed for horizontal to vertical edge lifts and handling of thin-walled precast concrete elements. Two steel protrusions or “ears” on the head of the anchor provide protection against concrete spalling. These protrusions restrict the ring clutch rotation during lateral pulls. As a result, lateral forces are transmitted directly to the edge of the anchor instead of the concrete.

The body of the Erection Anchor is shaped to allow full reinforcement for secure support and spall-free rotation.

P92 Erection Anchors are available plain or hot-dipped galvanized.

To Order:

Specify: (1) quantity, (2) name, (3) anchor style, (4) corrosion resistance, if required.

Example:

200, P92 Fleet-Lift Erection Anchors, FL047, hot-dipped galvanized.

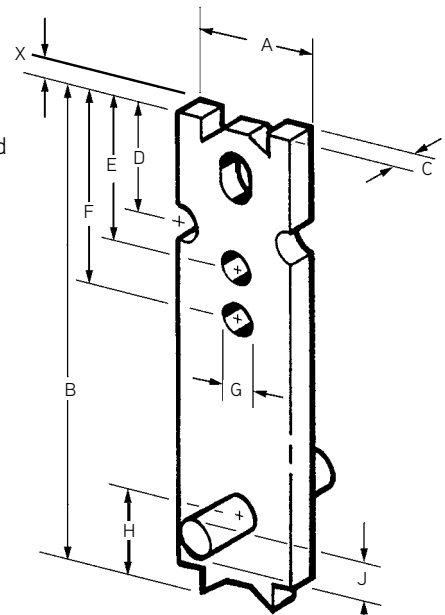

P92 Fleet-Lift Erection Anchor Dimensions

P92 Fleet-Lift Erection Anchor

Safe Working Load (Tons)	Product Code	A	B	C	D	E	F	G	H	J	X
2	FL047	2"	8"	3/8"	1-13/16"	2-3/8"	3-3/8"	5/8"	1"	1/2"	3/8"
4	FL048	2-1/2"	10-7/16"	5/8"	2-1/2"	3-3/16"	4-7/16"	3/4"	1-1/4"	3/4"	7/16"
8	FL049*	3-3/4"	13-1/4"	3/4"	3-1/8"	4"	5-3/4"	1"	1-3/4"	3/4"	5/8"

Note: Dimension X is distance from surface of concrete to anchor

Shear Reinforcement

Stress is caused during the edge lift of a panel, making supplemental reinforcement around the anchor necessary in thin panels. Fleet-Lift P98S Shear Bars are designed expressly for this purpose. Place the shear bar in the side notch of the anchor as shown in the sketch at right.

Reference P98S Shear Bar section for more information.

Note: A properly installed P98S Shear Bar is required to develop the shear safe working loads shown in the chart on the following page.

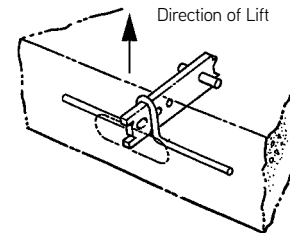

Typical P92 Fleet-Lift Erection Anchor/ Shear Bar Application

Tension Reinforcement

The P92 Dayton Superior Fleet-Lift Erection Anchor is manufactured with a steel tension pin that resists pullout during normal erection situations. The safe working load chart, on the following page, list two sets of tension values. If the higher safe working load is used, the anchor must be properly reinforced using the P98T Tension Reinforcement. The tension bar should be placed through the lower hole of the anchor.

Reference P98T Tension Reinforcement section for more information.

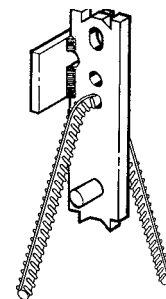

Typical P92 Fleet-Lift Erection Anchor/Tension Bar Application

Fleet-Lift System

P92 Fleet-Lift Erection Anchor Tension and Shear Capacities

P92 Fleet-Lift Erection Anchor (ton x length)	Product Code	Precast Concrete Panel Thickness	Shear Safe Working Load with Shear Bar	Tension Safe Working Load with Anchor Only	Tension Safe Working Load With Tension Bar
2-ton x 8" long	FL047	4" Min.	1,650 lbs.	2,575 lbs.	4,000 lbs.
		5"	1,875 lbs.	3,350 lbs.	
		6"	2,125 lbs.	3,850 lbs.	
		7"	2,400 lbs.	4,000 lbs.	
		8"	2,700 lbs.	4,000 lbs.	
		9"	2,925 lbs.	4,000 lbs.	
		10"	3,275 lbs.	4,000 lbs.	
		11"	3,575 lbs.	4,000 lbs.	
		12"	4,000 lbs.	4,000 lbs.	
4-ton x 10-7/16" long	FL048	5-1/2" Min.	2,400 lbs.	4,700 lbs.	8,000 lbs.
		6"	3,075 lbs.	5,050 lbs.	
		7"	3,250 lbs.	5,825 lbs.	
		8"	3,425 lbs.	6,600 lbs.	
		9"	3,825 lbs.	7,350 lbs.	
		10"	4,250 lbs.	8,000 lbs.	
		11"	4,650 lbs.	8,000 lbs.	
		12"	5,050 lbs.	8,000 lbs.	
8-ton x 13-1/4" long	FL049	7-1/2" Min.	4,000 lbs.	7,500 lbs.	16,000 lbs.
		8"	4,200 lbs.	7,775 lbs.	
		9"	4,550 lbs.	8,300 lbs.	
		10"	4,950 lbs.	8,800 lbs.	
		11"	5,050 lbs.	10,000 lbs.	
		12"	5,175 lbs.	11,300 lbs.	

Notes:

1. Safe Working Loads are based on approximately a 4 to 1 factor of safety in 3,500 psi normal weight concrete.
2. Install shear bar and tension bar, when required, per instructions on preceding page.

P92P Fleet-Lift Erection Anchor with Shear Plate

The P92P Fleet-Lift Erection Anchor with Shear Plate is designed specifically for edge tilting precast concrete elements from the horizontal to a vertical position. An integral shear plate eliminates any possibility of forgetting to install a required shear bar.

As on other Fleet-Lift Erection Anchors, two steel protrusions or “ears” at the head of the anchor provide protection against concrete spalling. These “ears” restrict the ring clutch rotation during lateral pulls. As a result, lateral forces are transmitted directly to the edge of the anchor instead of the concrete.

The body of the erection anchor is shaped to allow full reinforcement for secure support and spill-free rotation.

P92P Erection Anchors are available plain or hot-dipped galvanized.

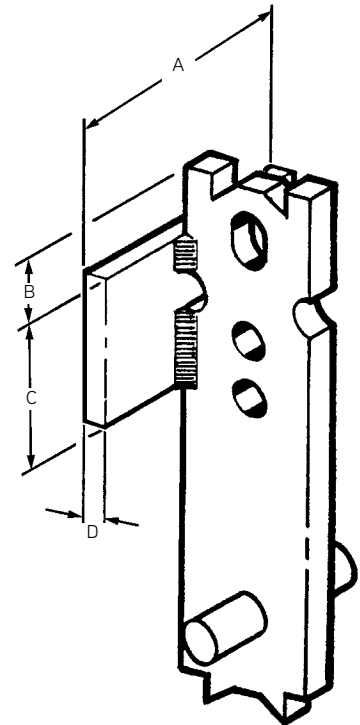

P92P Fleet-Lift Erection Anchor with Shear Plate

To Order:
Specify: (1) quantity, (2) name, (3) product code, (4) corrosion resistance, if required.

Example:
200, P92P Fleet-Lift Erection Anchor with Shear Plate, FL148, hot-dipped galvanized.

Safe Working Load (Tons)	Product Code	A	B	C	D
2	FL147	2-1/2"	3/4"	3"	1/4"
4	FL148	2-1/2"	1-1/4"	3"	3/8"
8	FL149*	3"	1-5/8"	3-1/2"	3/8"

Anchor dimensions not shown are the same as the P92 Erection Anchor of the same load range.

Shear Reinforcement

Stress is caused during the edge lifting of a precast panel, making supplemental reinforcement around the anchor necessary in thin panels. The Fleet-Lift P92P Erection Anchor with integral Shear Plate is designed expressly for this purpose. Install the anchor so that the shear plate is opposite the direction of lift.

Typical P92P Fleet-Lift Erection Anchor with Shear Plate Application

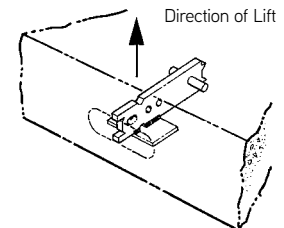

Tension Reinforcement

The P92P with Shear Plate Fleet-Lift Erection Anchor is manufactured with a steel tension pin that resists pullout during normal erection situations. The safe working load chart on the following page lists two sets of tension values. If the higher safe working load is used, the anchor must be properly reinforced using the P98T Tension Bar. The tension bar should be placed through the lower hole.

Typical P92P Fleet-Lift Erection Anchor Shear Plate/Tension Bar Application

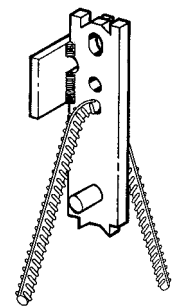

P92P Fleet-Lift Erection Anchor with Shear Plate Capacities

P92 Fleet-Lift Erection Anchor (ton x length)	Product Code	Precast Concrete Panel Thickness	Shear Safe Working Load with Shear Bar	Tension Safe Working Load with Anchor Only	Tension Safe Working Load With Tension Bar
2-ton x 8" long	FL147	3-1/2" Min.	1,450 lbs.	2,575 lbs.	4,000 lbs.
		4"	1,625 lbs.	2,575 lbs.	
		5"	2,050 lbs.	3,350 lbs.	
		6"	2,350 lbs.	3,750 lbs.	
		7"	2,625 lbs.	3,850 lbs.	
		8"	2,850 lbs.	4,000 lbs.	
		9"	3,050 lbs.	4,000 lbs.	
		10"	3,225 lbs.	4,000 lbs.	
		11"	3,425 lbs.	4,000 lbs.	
		12"	3,675 lbs.	4,000 lbs.	
4-ton x 10-7/16" long	FL148	4" Min.	2,150 lbs.	3,450 lbs.	8,000 lbs.
		5"	2,625 lbs.	4,250 lbs.	
		6"	3,100 lbs.	5,075 lbs.	
		7"	3,525 lbs.	5,825 lbs.	
		8"	3,925 lbs.	6,600 lbs.	
		9"	4,275 lbs.	7,350 lbs.	
		10"	4,600 lbs.	8,000 lbs.	
		11"	4,900 lbs.	8,000 lbs.	
8-ton x 13-1/4" long	FL149	6" Min."	4,000 lbs.	5,580 lbs.	16,000 lbs.
		7"	4,250 lbs.	6,870 lbs.	
		8"	4,475 lbs.	7,775 lbs.	
		9"	4,725 lbs.	8,300 lbs.	
		10"	4,950 lbs.	8,800 lbs.	
		11"	5,200 lbs.	10,000 lbs.	
		12"	5,450 lbs.	11,300 lbs.	

Notes:

- 1) Safe Working Loads are based on approximately a 4 to 1 factor of safety in 3,500 psi normal weight concrete.
- 2) FL449 uses 8-10T P99 Recess and P91 Ring Clutch.

P92DP Fleet-Lift Erection Anchor with Shear Plate and Shear Pin

The Dayton Superior P92DP Fleet-Lift Erection Anchor with a Shear Plate and a Shear Pin is similar to the P92P anchor with the addition of a shear pin. By welding a solid shear pin opposite the shear plate, the anchor can resist shear loads in both directions.

Installation and Primary Shear Loading

The P92DP anchor is set in the form with the shear plate in the down position to resist the primary shear load.

Secondary Shear Loading

When the panel is placed on an "A" frame is required to be rotated 180°, the addition of the shear pin works with the shear plate to resist the shear load in the opposite direction of the shear plate. The shear pin helps to protect the concrete from spalling when the shear loads are applied in a secondary direction.

P92DP Erection Anchors are available either plain or hot-dipped galvanized steel.

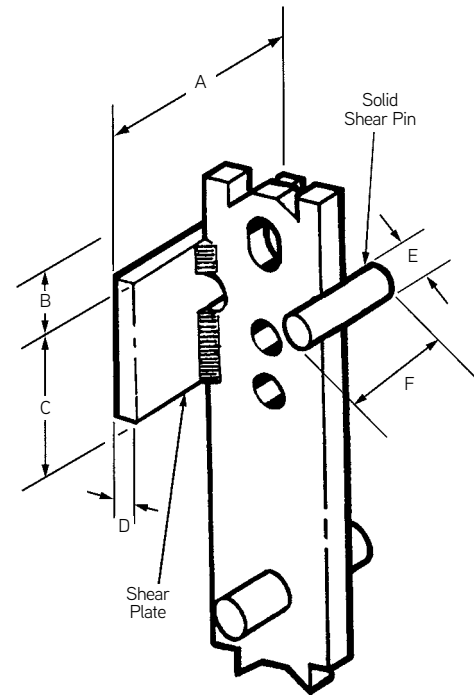

P92DP Fleet-Lift Erection Anchor with Shear Plate/Pin

To Order:

Specify: (1) quantity, (2) name, (3) product code, (4) corrosion resistance, if required.

Example:

200, P92DP Fleet-Lift Erection Anchor with Shear Plate/Pin, FL744, 4/6-ton system size, hot-dipped galvanized.

Safe Working Load (Tons)	Product Code	A	B	C	D	E	F
2	FL647	2-1/2"	3/4"	3"	1/4"	1/2"	2-3/4"
4	FL648	2-1/2"	1-1/4"	3"	3/8"	3/4"	2-7/8"
8	FL649	3"	1-5/8"	3-1/2"	3/8"	3/4"	2-7/8"

Anchor dimensions not shown are the same as the P92 Erection Anchor of the same load range.

Tension Reinforcement

The P92DP Fleet-Lift Erection Anchor is manufactured with a steel tension pin that resists pullout during normal erection situations. The safe working load chart on the following page lists two sets of tension values. If the higher safe working load is used, the anchor must be properly reinforced using the P98T Tension Bar. The tension bar should be placed through the lower hole of the anchor.

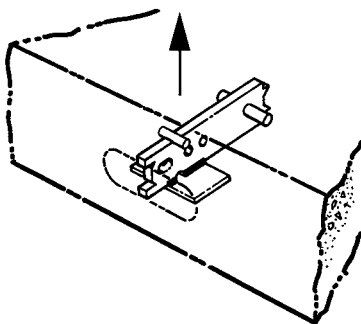

Direction of Lift for Primary Shear

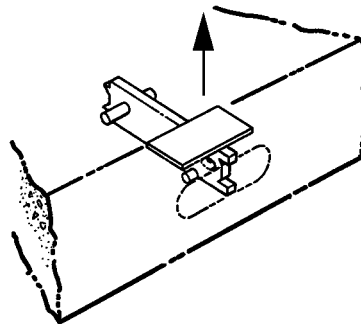

Direction of Lift for Secondary Shear

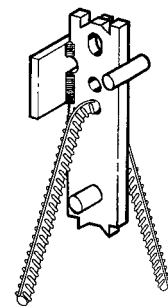

P92DP Fleet-Lift Erection Anchor with Shear Plate and Shear Pin Capacities

P92DP Fleet-Lift Erection Anchor (ton x length)	Product Code	Precast Concrete Panel Thickness	Shear Safe Working Load with Shear Bar	Tension Safe Working Load with Anchor Only	Tension Safe Working Load With Tension Bar
2-ton x 8" long	FL647	3-1/2" Min.	1,450 lbs.	2,575 lbs.	4,000 lbs.
		4"	1,625 lbs.	2,575 lbs.	
		5"	2,050 lbs.	3,350 lbs.	
		6"	2,350 lbs.	3,750 lbs.	
		7"	2,625 lbs.	3,850 lbs.	
		8"	2,850 lbs.	4,000 lbs.	
		9"	3,050 lbs.	4,000 lbs.	
		10"	3,225 lbs.	4,000 lbs.	
		11"	3,425 lbs.	4,000 lbs.	
		12"	3,675 lbs.	4,000 lbs.	
4-ton x 10-7/16" long	FL648	4" Min.	2,150 lbs.	3,450 lbs.	8,000 lbs.
		5"	2,625 lbs.	4,250 lbs.	
		6"	3,100 lbs.	5,075 lbs.	
		7"	3,525 lbs.	5,825 lbs.	
		8"	3,925 lbs.	6,600 lbs.	
		9"	4,275 lbs.	7,350 lbs.	
		10"	4,600 lbs.	8,000 lbs.	
		11"	4,900 lbs.	8,000 lbs.	
8-ton x 13-1/4" long	FL649	6" Min."	4,000 lbs.	5,580 lbs.	16,000 lbs.
		7"	4,250 lbs.	6,870 lbs.	
		8"	4,475 lbs.	7,775 lbs.	
		9"	4,725 lbs.	8,300 lbs.	
		10"	4,950 lbs.	8,800 lbs.	
		11"	5,200 lbs.	10,000 lbs.	
		12"	5,450 lbs.	11,300 lbs.	

Notes:

- 1) Safe Working Load is based on an approximate factor of safety of 4 to 1 in 3,500 psi normal weight concrete.
- 2) Install anchors as shown on preceding page to develop safe working loads in chart.

P92FE Fleet Lift Forged Erection Anchor

The Dayton Superior P92FE Forged Erection Anchor is specifically designed to provide greater lifting capacities for horizontal to vertical edge lifts. The anchors are forged to provide 20% greater safe working loads. The head of the anchor is designed with two protrusions or "ears" on the head of the anchor which provide protection against concrete spalling. These protrusions restrict the ring clutch rotation during lateral pulls. As a result, lateral forces are transmitted directly to the edge of the anchor instead of the concrete.

The P92FE Forged Erection Anchor utilizes the Fleet P91S or Fleet P91NC lifting hardware and the P99 Recess Plugs. P92FE Forged Erection Anchors are available in plain or hot-dipped galvanized finishes.



Fleet-Lift System

P92FE Capacity	Product Code (Plain)	Product Code (Galvanized)
3-Ton	126748	127518
6-Ton	143420	143421
10-Ton	143422	143423

To Order:

Specify: (1) quantity, (2) name, (3) product code, (4) finish.

Example:

200, P92FE Fleet-Lift Forged Erection Anchors, #126748, hot-dipped galvanized.

P92FE Forged Erection Anchor

Ton x Length	Slab Thickness	Insert Height	Minimum Edge Distance	Minimum Corner Distance	Shear Safe Working Load with Shear Bar	Tension Safe Working Load Anchor Only	Tension Safe Working Load with Tension Bar
3-ton x 8"	4" Min.	8"	2"	12"	1,390 lbs.	2,500 lbs.	6,000 lbs.
	5"		2-1/2"		1,680 lbs.	3,130 lbs.	
	6"		3"		1,980 lbs.	3,760 lbs.	
	7"		3-1/2"		2,300 lbs.	4,380 lbs.	
	8"		4"		2,630 lbs.	5,010 lbs.	
	9"		4-1/2"		2,980 lbs.	5,640 lbs.	
	10"		5"		3,340 lbs.	6,000 lbs.	
	11"		5-1/2"		3,720 lbs.	6,000 lbs.	
6-ton x 10-3/8"	5-1/2" Min.	10-3/8"	2-3/4"	16"	2,840 lbs.	4,720 lbs.	12,000 lbs.
	6"		3"		3,030 lbs.	5,150 lbs.	
	7"		3-1/2"		3,430 lbs.	6,010 lbs.	
	8"		4"		3,840 lbs.	6,870 lbs.	
	9"		4-1/2"		4,270 lbs.	7,730 lbs.	
	10"		5"		4,710 lbs.	8,590 lbs.	
	11"		5-1/2"		5,010 lbs.	9,450 lbs.	
	12"		6"		5,540 lbs.	10,310 lbs.	
10-ton x 12-3/4"	7 1/2"	12-3/4"	3-3/4"	19"	4,180 lbs.	7,920 lbs.	20,000 lbs.
	8"		4"		4,420 lbs.	8,440 lbs.	
	9"		4-1/2"		4,920 lbs.	9,500 lbs.	
	10"		5"		5,430 lbs.	10,560 lbs.	
	11"		5-1/2"		5,950 lbs.	11,610 lbs.	
	12"		6"		6,490 lbs.	12,670 lbs.	

Safe Working Load provides a factor of safety approximately 4 to 1 in 3,500 psi normal weight concrete.

P92FEW Fleet Lift Forged Erection Anchor with Shear Plate

The P92FEW Forged Erection Anchor with Shear Plate eliminates the need for a shear bar. The P92FE and P92FEW anchors are stocked in a plain finish and can be galvanized locally.

P92FEW Capacity	Product Code (Plain)	Product Code (Galvanized)
3 Ton	129473	139577
6 Ton	143424	143425
10 Ton	143426	143427



Fleet-Lift System

To Order:

Specify: (1) quantity, (2) name, (3) product code, (4) finish.

Example:

200, P92FEW Fleet-Lift Forged Erection Anchors, #139577, hot-dipped galvanized.

P92FEW Fleet Forged Erection Anchor

Ton x Length	Slab Thickness	Minimum Edge Distance	Minimum Corner Distance	Shear Safe Working Load with Shear Plate	Tension Safe Working Load Anchor Only	Tension Safe Working Load with Tension Bar
3 Ton x 8"	4"	2"	12"	1,800 lbs	6,000 lbs	6,000 lbs
	5"	2-1/2"		2,300 lbs		
	6"	3"		2,800 lbs		
	7"	3-1/2"		3,400 lbs		
	8"	4"		4,000 lbs		
	9"	4-1/2"		4,400 lbs		
	10"	5"		4,800 lbs		
	11"	5-1/2"		5,200 lbs		
6 Ton x 10-3/8"	5-1/2"	2-3/4"	16"	3,100 lbs	10,000 lbs	12,000 lbs
	6"	3"		3,250 lbs	10,500 lbs	
	7"	3-1/2"		3,700 lbs	11,500 lbs	
	8"	4"		4,040 lbs	12,000 lbs	
	9"	4-1/2"		4,600 lbs	12,000 lbs	
	10"	5"		5,000 lbs	12,000 lbs	
	11"	5-1/2"		5,500 lbs	12,000 lbs	
	12"	6"		6,100 lbs	12,000 lbs	
10 Ton x 12-3/4"	7-1/2"	3-3/4"	19"	4,600 lbs	17,500 lbs	20,000 lbs
	8"	4"		4,800 lbs	18,000 lbs	
	9"	4-1/2"		5,450 lbs	19,000 lbs	
	10"	5"		6,100 lbs	20,000 lbs	
	11"	5-1/2"		6,800 lbs	20,000 lbs	
	12"	6"		7,600 lbs	20,000 lbs	

Safe Working Load provides a factor of safety approximately 4 to 1 in 3,500 psi normal weight concrete.

P92FEWDP Forged Erection Anchor with Shear Plate and Secondary Shear Pin

The P92FEWDP Forged Erection Anchor with Shear Plate is specifically designed to provide greater lifting capacities for horizontal to vertical edge lifts. By welding a solid shear pin opposite the shear plate, the anchor can resist shear loads in both directions. The anchors are forged to provide 20% greater safe working loads. The P92FEWDP eliminates the need for a shear bar on the primary and secondary shear loading.

Due to the anchor being forged, it does not depend on welds or thread engagement to develop its safe working load. Forging provides maximum safety with its advantageous material structure. This allows the anchor to easily meet the OSHA requirement of 4 to 1 factor of safety.

P92FEWDP	Product Code (Plain)	Product Code (Galvanized)
3 Ton	142881	MTO
6 Ton	142882	MTO
10 Ton	142883	MTO



PRODUCT APPLICATION:

The P92FEWDP Forged Erection Anchor with Shear Plate and Secondary Shear Pin is designed specifically for edge tilting precast concrete elements from the horizontal to vertical position. When the panel is placed on an "A" frame or is required to be rotated 180°, the addition of the shear pin works with the shear plate to resist the shear load in the opposite direction of the shear plate. The shear pin helps to protect the concrete from spalling when the shear loads are applied in a secondary direction.

PRODUCT FEATURES AND BENEFITS:

The P92FEWDP has two steel protrusions or "ears" at the head of the anchor which provides protection against concrete spalling. These "ears" restrict the ring clutch rotation during lateral pulls. As a result, lateral forces are transmitted directly to the edge of the anchor instead of the concrete.

The P92FEWDP Forged Erection Anchor utilizes the Fleet P91S or Fleet P91NC lifting hardware and the P99 Recess Plugs.

The P92FEWDP Forged erection Anchors are available in a plain finish.

To Order:

Specify: (1) quantity, (2) name, (3) product code, (4) finish.

Example:

200, P92FEWDP 3-Ton 8" Fleet-Lift Forged Erection Anchor with Shear Plate and Secondary Shear Pin, 142881, plain finish.

INSTALLATION:

The P92FEWDP anchor is set in the form with the shear plate in the down position to resist the primary shear load.

P92FEWDP Forged Erection Anchor (Ton x Length)	Product Code	Slab Thickness	Shear Safe Working Load Primary Shear	Shear Safe Working Load Secondary Shear	Tension Safe Working Load Anchor Only	Tension Safe Working Load with Tension Bar
3 Ton x 8"	142881	4"	1,800 lbs	1,390 lbs	6,000 lbs	6,000 lbs
		8"	4,000 lbs	3,000 lbs		
		12"	5,700 lbs	4,425 lbs		
6 Ton x 10-3/8"	142882	5-1/2"	3,100 lbs	2,560 lbs	10,000 lbs	12,000 lbs
		8"	4,040 lbs	3,660 lbs	12,000 lbs	
		12"	6,100 lbs	5,600 lbs	12,000 lbs	
10 Ton x 12-3/4"	142883	7-1/2"	4,600 lbs	3,630 lbs	17,500 lbs	20,000 lbs
		10"	6,100 lbs	4,900 lbs	20,000 lbs	
		12"	7,600 lbs	6,520 lbs	20,000 lbs	

Safe working load provides a factor of safety approximately 4 to 1 in 3,500 psi normal weight concrete

P92H Fleet-Lift Two-Hole Erection Anchor P92HP Fleet-Lift Two-Hole Erection Anchor with Shear Plate

Fleet-Lift Two-Hole Erection Anchors combine the strength, spall resistance and high tension performance of the P92 Erection Anchor.

The P92H Two-Hole Erection Anchor was designed for use where the lift direction applies a tension load ONLY to the anchor. A properly installed P98T Tension Bar is always required when using this erection anchor. For shear applications the P98S Shear Bar is designed to fit over the top edge of the anchor. The design of the shear bar allows it to fit over the top edge of the anchor. It is placed in the top notch and secured so that it bears tightly against the bottom of the notch. Accurate placement of the shear bar provides for spall-free edge lifting.

The P92HP Two-Hole Erection Anchor was designed for use where the lift direction applies both a shear and tension load to the anchor. As with the P92H anchor, a properly installed P98T Tension Bar is always required when using the P92HP Erection Anchor. Shear loading for this anchor is resisted by the P92HP anchor's integral shear plate.

Both the P92H and P92HP Erection Anchors are available in 2, 4, 6 or 8-ton capacities. In addition, they are available in either plain or hot-dipped galvanized finish.

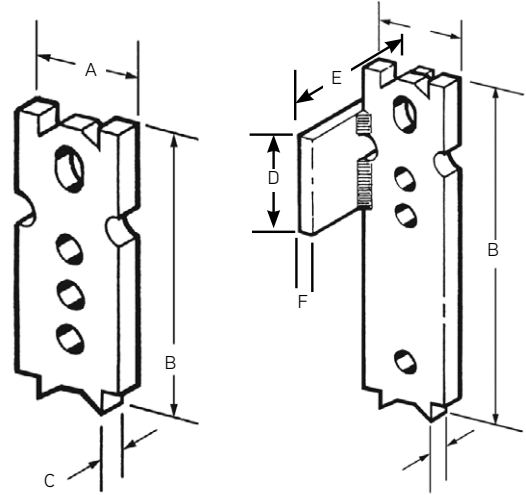

P92H Fleet-Lift Two-Hole Erection Anchor (Tension Loadings ONLY)

P92HP Fleet-Lift Two-Hole Erection Anchor with Shear Plate (Shear and Tension Loading)

Fleet-Lift System

To Order:

Specify: (1) quantity, (2) name, (3) product code, (4) corrosion resistance, if required.

Example:

200, P92H Fleet-Lift Two-Hole Erection Anchor, FL075, hot-dipped galvanized.

P92H Fleet-Lift Two-Hole Erection Anchor (ton x length)	Product Code	A	B	C	P92HP Fleet-Lift Two-Hole Erection Anchor with Shear plate (ton x length)	Product Code	D	E	F
2-ton x 4-1/4" long	FL403	2"	4-1/4"	3/8"	2-ton x 4-1/4" long	FL423	2-1/2"	3"	1/4"
2-ton x 8-1/4" long	FL903	2"	8-1/4"	3/8"	2-ton x 8-1/4" long	FL403L	2-1/2"	3"	1/4"
4-ton x 7-7/8" long	FL075	2-1/2"	7-7/8"	5/8"	4-ton x 7-7/8" long	FL275	2-1/2"	3"	3/8"
4-ton x 10-7/8" long	FL975	2-1/2"	10-7/8"	5/8"	4-ton x 10-7/8" long	FL175L	2-1/2"	3"	3/8"
8-ton x 13-1/4" long	FL185L	3-3/4"	13-1/4"	3/4"	8-ton x 13-1/4" long	FL285L	3"	3-1/2"	3/8"

Anchor dimensions not shown are the same as the P92 Erection Anchor of the same load range.

Shear Reinforcement

Stress is caused during the edge lifting of a precast concrete panel, making supplemental reinforcement around the anchor necessary in thin panels. The Fleet-Lift P92HP Erection Anchor with integral Shear Plate is designed expressly for this purpose. Install the anchor so that the shear plate is opposite the direction of lift.

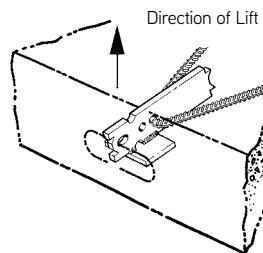

Typical P92HP Fleet-Lift Two-Hole Erection Anchor with Shear Plate Application

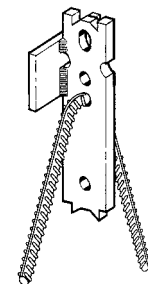

Typical P92HP Fleet-Lift Two-Hole Erection Anchor with Shear Plate/Tension Bar Application

Tension Reinforcement

The P92HP Fleet-Lift Erection Anchor with Shear Plate must be properly reinforced using the P98T Tension Bar. The tension bar should be placed through the lower hole.

P92H Fleet-Lift Two-Hole Erection Anchor and P92HP Fleet-Lift Two-Hole Erection Anchor with Shear Plate Capacities

Fleet-Lift System

P92H or P92HP Fleet-Lift Two-Hole Erection Anchor (ton x length)	Product Code	Precast Concrete Panel Thickness	P92HP With Shear Plate Safe Working Load	P92H or P92HP With Tension Bar Tension Safe Working Load
2-ton x 4-1/4" long	FL403	3-1/2" Min.	1,325 lbs.	4,000 lbs.
	FL423			
	FL403	4"	1,525 lbs.	
	FL423			
	FL403	5"	1,525 lbs.	
	FL423			
	FL403	6"	1,750 lbs.	
	FL423			
	FL403	7"	1,900 lbs.	
	FL423			
FL403	8"	2,075 lbs.		
FL423				
2-ton x 8-1/4" long	FL903	4"	1,650 lbs.	
	FL403L			
	FL903	5"	1,875 lbs.	
	FL403L			
	FL903	6"	2,125 lbs.	
	FL403L			
	FL903	7"	2,400 lbs.	
	FL403L			
	FL903	8"	2,700 lbs.	
	FL403L			
	FL903	9"	2,925 lbs.	
	FL403L			
	FL903	10"	3,275 lbs.	
	FL403L			
FL903	11"	3,575 lbs.		
FL403L				
FL903	12"	3,975 lbs.		
FL403L				
4-ton x 7-7/8" long	FL075	5-1/2" Min.	2,025 lbs.	8,000 lbs.
	FL275			
	FL075	6"	2,250 lbs.	
	FL275			
	FL075	7"	2,600 lbs.	
	FL275			
	FL075	8"	3,000 lbs.	
	FL275			
	FL075	9"	3,375 lbs.	
	FL275			
FL075	10"	3,750 lbs.		
FL275				
4-ton x 10-7/8" long	FL975	Same panel thickness and SWL's as FLO48		
	FL175L	Same panel thickness and SWL's as FL148		
8-ton x 13-1/4" long	FL185L	Same panel thickness and SWL's as FLO49		
	FL285L	Same panel thickness and SWL's as FL149		

Notes:

1. Safe Working Load provides an approximate factor of safety of 4 to 1 in 3,500 psi normal weight concrete.
2. Dayton Superior recommends the use of the P90HP Fleet-Lift Anchor when shear loads will be encountered.

P92FEH Fleet-Lift Forged Erection Anchor

The P92 FEH Forged Erection Anchor is specifically designed to provide greater lifting capacities as related to stamped anchors. The anchors are forged to provide 30% greater safe working loads. The P92 FEH uses a tension bar to achieve the required loads.

Because the anchor is forged, it does not depend on welds or thread engagement to develop its safe working load. Forging provides an advantageous material structure that allows increased strength. This allows the anchor to easily meet the OSHA requirement of 4 to 1 factor of safety.



Application

The P92FEH Forged Erection Anchor is designed specifically for applications where a high-performance anchor is required for tension loads ONLY. A properly installed P98T Tension Bar is always required when using this anchor. For shear applications, the P98S Shear Bar fits over the top edge of the P92FEW Anchor. It is placed in the top notch and secured so the it bears tightly against the bottom of the notch. Accurate placement of the shear bar provides spall-free edge lifting.

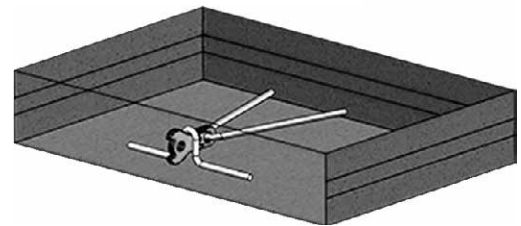

Fleet-Lift System

Features

- The P2FEH has two steel protrusions (or "ears") at the head of the anchor protect against concrete spalling. They restrict the ring clutch rotation during lateral pulls. As a result, lateral forces are transmitted directly to the edge of the anchor instead of the concrete.
- The P92FEH Forged Erection Anchor utilizes the Fleet-Lift P91S or P91NC lifting hardware and the P99 Recess Plugs
- P92FEH Forged Erection Anchors are available in plain or Hot dipped galvanized (special order) finishes.

Product Code	Material	Load Rating	Slab Thickness	Minimum Edge Distance	Minimum Corner Distance	Shear Safe Working Load with Shear Bar	Tension Safe Working Load with Tension Bar
129852	Plain	3 ton	4"	2"	12"	1,650 lbs	6,000 lbs
			5"	2-1/2"		1,875 lbs	
			6"	3"		2,125 lbs	
			7"	3-1/2"		2,400 lbs	
			8"	4"		2,700 lbs	
			9"	4-1/2"		2,925 lbs	
			10"	5"		3,275 lbs	
			11"	5-1/2"		3,575 lbs	
			12"	6"	4,000 lbs		
129853	Plain	6 ton	5-1/2"	2-3/4"	16"	2,400 lbs	12,000 lbs
			6"	3"		3,075 lbs	
			7"	3-1/2"		3,250 lbs	
			8"	4"		3,425 lbs	
			9"	4-1/2"		3,825 lbs	
			10"	5"		4,250 lbs	
			11"	5-1/2"		4,650 lbs	
			12"	6"		5,050 lbs	
129854	Plain	10 ton	7-1/2"	3-3/4"	19"	4,000 lbs	20,000 lbs
			8"	4"		4,200 lbs	
			9"	4-1/2"		4,550 lbs	
			10"	5"		4,950 lbs	
			11"	5-1/2"		5,050 lbs	
			12"	6"		5,175 lbs	

Safe Working Load provides a Safety factor of approximately 4 to 1 in 3,500 psi normal weight concrete.

P92S Fleet-Lift Sandwich Panel Erection Anchor

P92SP Fleet-Lift Sandwich Panel Erection Anchor with Shear Plate

The Fleet-Lift Sandwich Panel Erection Anchor is designed to erect precast, insulated sandwich panels with a minimum loss of insulation. The anchor uses standard Fleet-Lift recess plugs and ring clutches.

The P92S Sandwich Panel Erection Anchor is designed for use with 2", 3" and 4" thick insulated sandwich panels.

The design of the anchor allows it to distribute anchor loads evenly to both concrete wythes. This is accomplished by the use of two specially bent rebars per sandwich panel anchor. The sandwich panel erection anchor, with its unique anchor head shape, in combination with the two bent rebars, transfers both the anchor's shear and tension loads evenly into each of the concrete wythes.

Place one bent rebar through the anchor's top hole and the second rebar through the anchor's bottom hole. The rebar extend from the anchor into the top and bottom wythe of concrete. The two specially bent rebar must be used with the sandwich panel erection anchor to achieve the safe working loads shown.

The P92SP Sandwich Panel Erection Anchor is similar in design and action to the P92S anchor, and has a built-in shear plate. The shear plate improves shear capacity when used in the 2", 3" and 4" thick wythes.

Both the P92S and P92SP anchors are available in plain or hot-dipped galvanized finish.

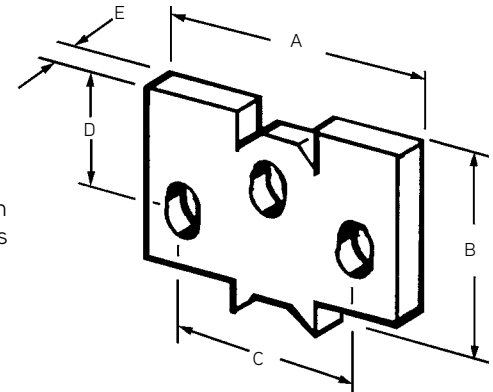

P92S Fleet-Lift Sandwich Panel Erection Anchor

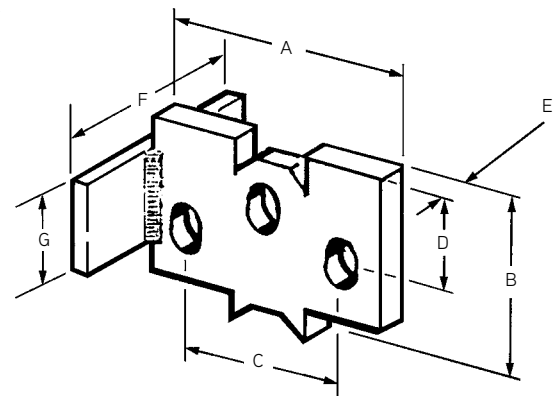

P92SP Sandwich Panel Erection Anchor with Shear Plate

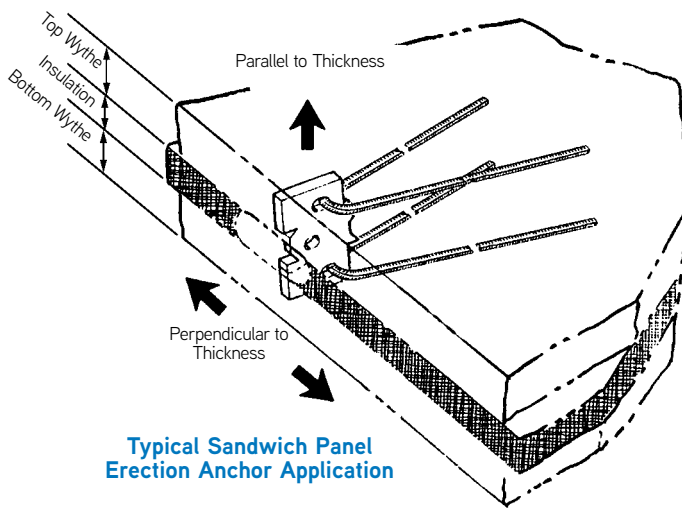

Typical Sandwich Panel Erection Anchor Application

To Order:

Specify: (1) quantity, (2) name, (3) product code, (4) finish.

Example:

200, P92S Fleet-Lift Sandwich Panel Erection Anchor, FL077, hot-dipped galvanized.

Anchor Tonnage	Product Code	Shear Plate	A	B	C	D	E	F	G
4-ton	FL077	No	6"	3-3/4"	4-3/8"	1-13/16"	5/8"	-	-
	FL230	Yes	6"	3-3/4"	4-3/8"	1-13/16"	5/8"	3"	2"
8-ton	FL184	No	6"	4-3/4"	4"	3-3/8"	3/4"	-	-
	FL284G	Yes	6"	4-3/4"	4"	3-3/8"	3/4"	3"	3-1/2"
10-ton	145569	Yes	7"	4-3/4"	5"	3-3/8"	3/4"	-	-
	145570	Yes	8"	4-3/4"	6"	3-3/8"	3/4"	-	-

P92SF Fleet-Lift Sandwich Panel Erection Anchor

The P92SF Fleet-Lift Sandwich Panel Erection Anchor (Patent #5,857,296) is designed to erect precast insulated sandwich panels with a minimum loss of insulation. The P92SF Sandwich Panel Erection Anchor is designed for use with the most common insulation thickness. The head of the anchor is designed with two protrusions on the head of the anchor which provide protection against concrete spalling. These protrusions restrict the ring clutch rotation during lateral pulls. As a result, lateral forces are transmitted directly to the edge of the anchor instead of the concrete. The design of the anchor allows it to distribute anchor loads evenly to both concrete wythes. This is accomplished by the use of two Tension Bars placed through the holes at the end of the anchor.

Due to the anchor being forged, it does not depend on welds or thread engagement to develop its safe working load. Forging provides maximum safety with its advantageous material structure. This allows the anchor to easily meet the OSHA requirement of 4 to 1 factor of safety.

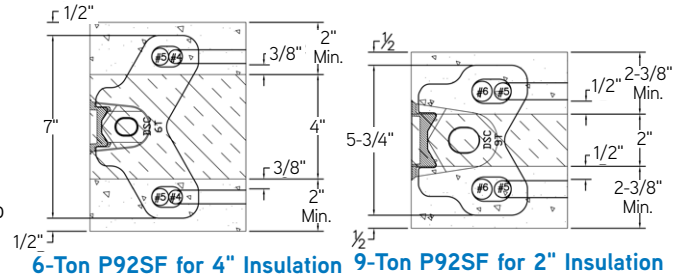

Application

The P92SF is installed in concrete for tension lifting applications.

Features

- Forged design creates up to 33% higher load capacity than stamped anchors which can reduce the number of anchors required.
- Plain or galvanized finishes available. Meets non-rusting requirements.
- Forged material minimizes rust and can result in eliminating galvanizing requirement for some projects.
- Design eliminates steel near top edge of face of panel, reducing opportunity for cracks occurring.
- Two Tension Bars must be used with the Sandwich Panel Erection Anchor to achieve the Safe Working Loads shown.

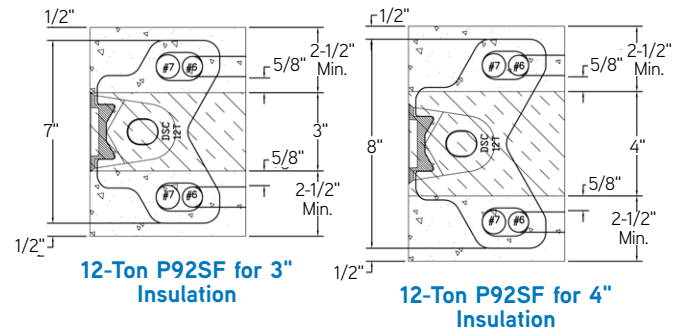

Technical Data

Product Code		Anchor Tonnage	Anchor Length	Concrete Compressive Strength	Insulated Panel Thicknesses	Shear Parallel to Thickness	Shear Perpendicular to Thickness	Tension	Tension Rebar	Shear Rebar
Plain	HDG									
143700	143701	6-ton	7"	3,500 psi	2" x 4" x 2"	2,675 lbs	8,200 lbs	12,000 lbs.	#4 x 34" Gr 60	#5 x 6" Gr 60
				3,500 psi	3" x 3" x 3"	4,509 lbs	9,600 lbs			
145081	145566	9-ton	5.75"	3,500 psi	3" x 2" x 3"	4,400 lbs	8,700 lbs	18,000 lbs.	#5 x 42" Gr 60	#6 x 6" Gr 60
				3,500 psi	4" x 2" x 2"	4,600 lbs	9,260 lbs			
145572	145718	12-ton	7"	4,500 psi	3" x 3" x 3"	4,700 lbs	10,900 lbs	24,000 lbs.	#6 x 66" Gr 60	#7 x 6" Gr 60
145573	145719		8"	4,500 psi	4" x 4" x 3"	4,400 lbs	9,200 lbs			

* Safe Working Loads based on 4:1 Safety Factor

Installation

1. Place one configured Tension Bar through the holes of the anchor extending from the anchor into the top and bottom wythe of concrete.
2. Place Shear Bars through top of Tension Bar slot next to Tension Bars.

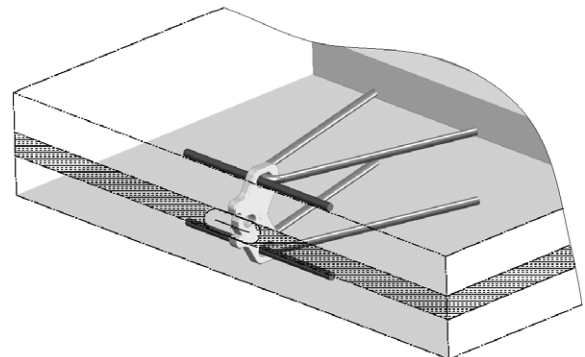

P92T Fleet-Lift Sandwich Panel Reinforcing Bars

Anchor Tonnage	Anchor Product Code	Rebar
4-ton	FL077	#4 Grade 60 x 34" overall
6-ton	143700	#4 Grade 60 x 34" overall
8 or 9-ton	FL184 FL284 145081	#5 Grade 60 x 42" overall
10 or 12-ton	145569 145570 145572 145573	#6 Grade 60 x 66" overall

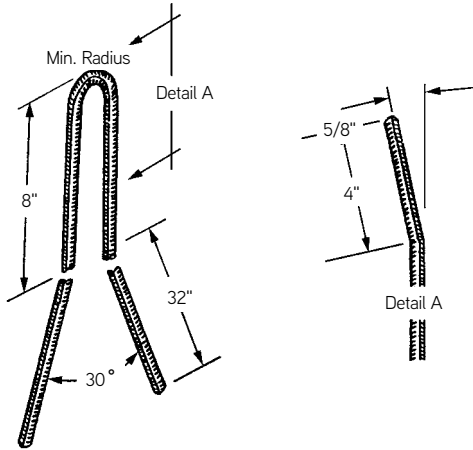

Rebar for 2" x 2" x 2" Panel

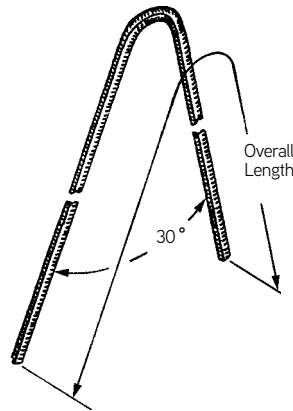

Rebar for 3" x 2" x 3",
2" x 2" x 4", 3" x 3" x 3" and
3" x 4" x 3" Panels

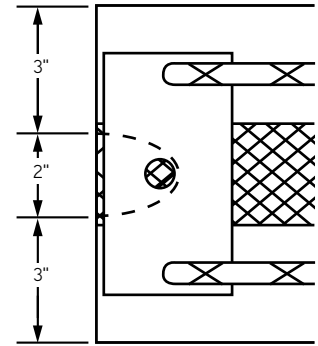

3" x 2" x 3" Panel

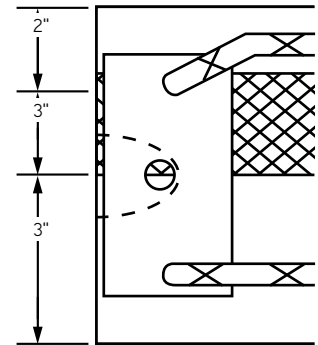

2" x 3" x 3" Panel

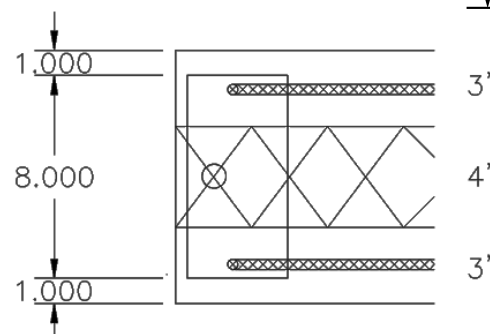
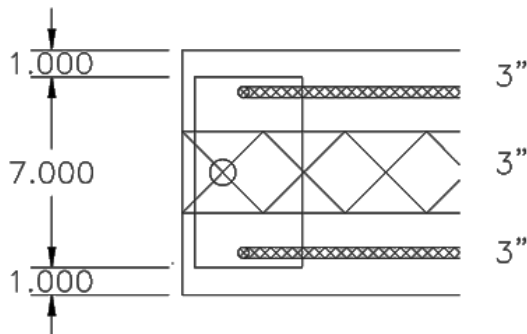

Fleet Lift Sandwich Panel Erection Anchor Safe Working Loads

Anchor Tonnage	For Anchor	Concrete Compressive Strength	Insulated Panel Thickness	Shear Parallel to Thickness	Shear Perpendicular to Thickness	Tension
4-ton	FL077	4,500 psi	2" x 2" x 4"	3,300 lbs	8,000 lbs	8,000 lbs
		3,500 psi	3" x 2" x 3"	3,425 lbs	8,000 lbs	
8-ton	FL184	4,500 psi	3" x 2" x 3"	3,850 lbs	9,900 lbs	16,000 lbs
		4,500 psi	2" x 2" x 4"	3,450 lbs	10,500 lbs	
8-ton	FL284	4,500 psi	4" x 2" x 2"	4,600 lbs	9,870 lbs	15,400 lbs
		4,500 psi	3" x 2" x 3"	4,400 lbs	8,800 lbs	
10-ton	145569	4,500 psi	3" x 3" x 3"	4,700 lbs	10,900 lbs	20,000 lbs
	145570	4,500 psi	3" x 4" x 3"	4,400 lbs	9,200 lbs	

Safe Working Loads based on 4:1 SF
 Minimum edge distance is 2'-0"
 Must use proper tension bar to achieve loads

Fleet-Lift System

P92AH Fleet-Lift Erection Anchor with 45° Head with Shear Plate

The Dayton Superior P92AH Fleet-Lift Erection Anchor with 45° Head and Shear Plate is designed for use when the lifting edge is beveled at a 45° angle. The factory installed shear plate eliminates the need for any additional shear reinforcement.

Installation

To install the P92AH anchor, position the anchor a minimum of 3/4" and a maximum of 1-1/2" clear of the casting bed. This can be accomplished using any of the standard recess members. After the anchor has been secured in place, tension reinforcement may be added, if desired. After the concrete has set, removal of the edge form and recess member will expose the head of the anchor for easy attachment of the lifting eye.

Tension Reinforcement

Due to the geometry of the anchor the loads shown in the table should not be exceeded, even if additional tension reinforcement is present.

P92AH Erection Anchors are available plain, or hot-dipped galvanized.

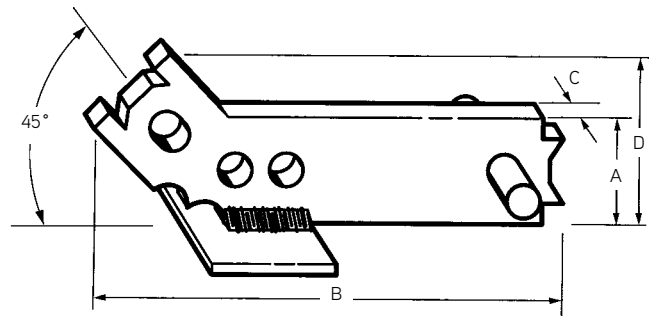

P92AH Fleet-Lift Erection Anchor with 45° Head with Shear Plate

To Order:

Specify: (1) quantity, (2) name, (3) product code, (4) corrosion resistance, if required.

Example:

200, P92AH, Fleet-Lift Erection Anchor with 45° head, FL454, hot-dipped galvanized.

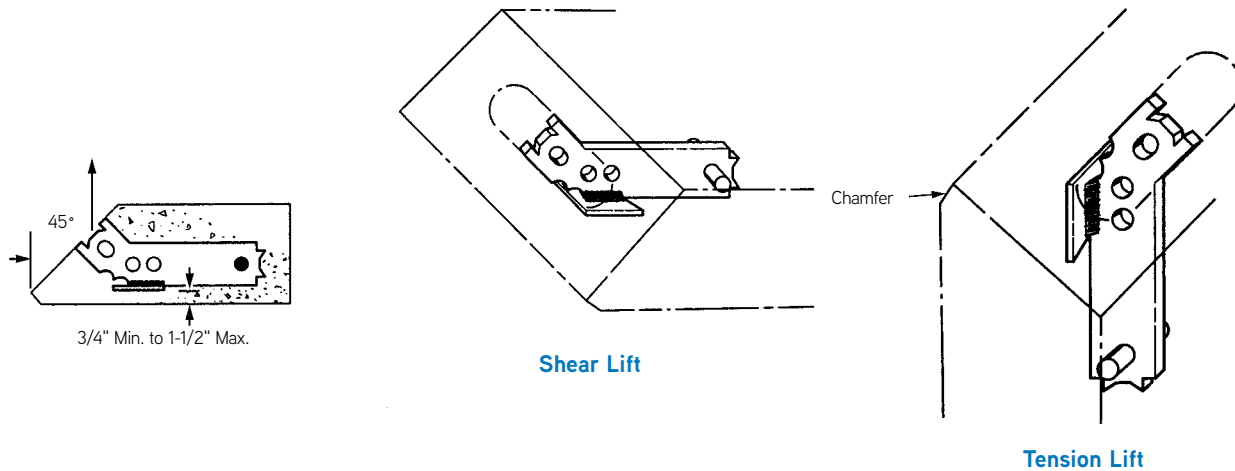

P92AH Fleet-Lift Erection Anchor (ton x length)	Product Code	Precast Concrete Panel Thickness	Shear Safe Working Load for Shear	Tension Safe Working Load Anchor Only	Tension Safe Working Load with Tension Bar	A	B	C	D
2-ton x 8-1/2" long	FL452	5" Min.	1,750 lbs.	2,650 lbs.	2,650 lbs.	2"	8-1/2"	3/8"	3-1/2"
		6"	2,150 lbs.	3,850 lbs.	3,850 lbs.				
4-ton x 11" long	FL454	6" Min.	2,400 lbs.	5,200 lbs.	5,200 lbs.	2-1/2"	11"	5/8"	4"
		8"	3,500 lbs.	6,200 lbs.	6,200 lbs.				
8-ton x 13-3/4" long	FL458	8" Min.	3,500 lbs.	7,500 lbs.	7,500 lbs.	3-3/4"	13-3/4"	3/4"	5-3/8"

Notes:

Safe Working Load provides an approximate factor of safety of 4 to 1 in 3,500 psi normal weight concrete. Safe Working Load is based on the anchor being located in the panel so that the shear plate is 3/4" minimum to 1-1/2" maximum from casting surface. Panel will not hang plumb, as the panel thickness, center of gravity and anchor location will determine the exact angle at which the panel will hang. Due to the design of this anchor, DO NOT attempt to use this anchor at loads higher than shown in this table – even with a properly installed tension bar. Anchor dimensions not shown are the same as the P92P Erection Anchor with Shear Plate of the same load range.

P93 Fleet-Lift L-Anchor

The Dayton Superior P93 Fleet-Lift L-Anchor is a very efficient anchor. This anchor is used for both stripping and erection carrying tension and/or shear loads (except for edge shear in thin panels). The L-Anchor produces exceptionally high pullout strength for its size, due to its foot design.

The L-Anchor can be placed on the face, back, or thicker panel edge allowing for back-stripping and their rotation from horizontal to vertical.

The P93 anchor is available in plain or hot-dipped galvanized finish. This anchor requires the use of the 2/5-ton range ring clutch and the 2/3-ton load range recess plug.

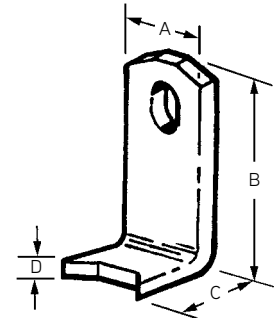

P93 Fleet-Lift L-Anchor

To Order:

Specify: (1) quantity, (2) name, (3) product code, (4) finish.

Example:

200 P93 Fleet-Lift L-Anchor, FL050, hot-dipped finish.

P93 Fleet-Lift L-Anchor (ton x length)	Product Code	Precast Concrete Panel Thickness	Minimum Edge or Corner Distance	Shear Safe Working Load for Shear	Tension Safe Working Load Anchor Only	A	B	C	D
1-ton x 4" long	FL050	5" Min.	12"	2,000 lbs.	2,000 lbs.	1-1/4"	4"	1-7/16"	3/16"

Notes:

Safe Working Load provides an approximate factor of safety of 4 to 1 in 3,500 psi normal weight concrete.

Anchor is not designed for use in thin edge shear conditions.

Anchor must use FL051 (P99) Reusable Recess Plug

P94 Fleet-Lift T-Anchor

The P94 Fleet-Lift T-Anchor is a versatile anchor available in many sizes and lengths. Its high pullout strength allows it to be used for back-stripping and erection. T-Anchors can be placed on the face, back or edge of panels allowing for back-stripping and rotation from horizontal to vertical.

P94 anchors are available in plain or hot-dipped galvanized finish.

To Order:

Specify: (1) quantity, (2) name, (3) product code, (4) finish.

Example:

200, P94 Fleet-Lift T-Anchors, FL850, hot-dipped galvanized.

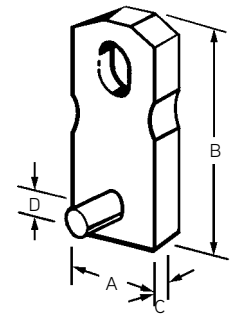

P94 Fleet-Lift T-Anchor 4-ton

P94 Fleet-Lift L-Anchor (ton x length)	Product Code	Min. Precast Concrete Panel Thickness	Minimum Edge or Corner Distance	Shear Safe Working Load	Tension Safe Working Load	A	B	C	D
2-ton x 4" long	FL110	4-3/4"	8"	4,000 lbs.	4,000 lbs.	1-1/4"	4"	3/8"	1/2"
2-ton x 5-1/2" long	FL059	5-7/8"	11"	4,000 lbs.	4,000 lbs.	1-1/4"	5-1/2"	3/8"	1/2"
4-ton x 4-1/4" long	FL848	4-5/8"	8-1/2"	5,500 lbs.	5,500 lbs.	1-1/2"	4-1/4"	5/8"	1/2"
4-ton x 4-3/4" long	FL849	5-1/8"	9-1/2"	7,100 lbs.	7,100 lbs.	1-1/2"	4-3/4"	5/8"	1/2"
4-ton x 5-1/4" long	FL850	5-5/8"	10-1/2"	8,000 lbs.	8,000 lbs.	1-1/2"	5-1/4"	5/8"	1/2"
4-ton x 5-3/4" long	FL851	6-1/8"	11-1/2"	8,000 lbs.	8,000 lbs.	1-1/2"	5-3/4"	5/8"	1/2"
4-ton x 6-1/4" long	FL852	6-5/8"	12-1/2"	8,000 lbs.	8,000 lbs.	1-1/2"	6-1/4"	5/8"	1/2"
4-ton x 6-3/4" long	FL853	7-1/8"	13-1/2"	8,000 lbs.	8,000 lbs.	1-1/2"	6-3/4"	5/8"	1/2"
4-ton x 7-1/4" long	FL854	7-5/8"	14-1/2"	8,000 lbs.	8,000 lbs.	1-1/2"	7-1/4"	5/8"	1/2"
4-ton x 7-3/4" long	FL855	8-1/8"	15-1/2"	8,000 lbs.	8,000 lbs.	1-1/2"	7-3/4"	5/8"	1/2"
6-ton x 11-1/8" long	FL319*	11-1/2"	23"	12,000 lbs.	12,000 lbs.	2-1/2"	11-1/8"	5/8"	3/4"
8-ton x 6-1/8" long	FL055	6-1/8"	12-1/4"	7,950 lbs.	7,950 lbs.	2-1/2"	6-1/8"	3/4"	3/4"
8-ton x 11-1/8" long	FL119	11-3/4"	23"	16,000 lbs.	16,000 lbs.	2-1/2"	11-1/8"	3/4"	3/4"

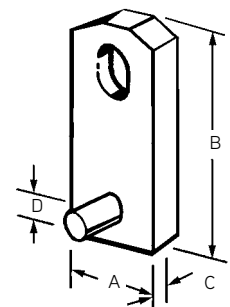

P94 Fleet-Lift T-Anchor 2, 6 and 8-ton

Safe Working Load provides a factor of safety of approximately 4 to 1 in 3,500 psi normal weight concrete.

Side notches are provided on 4-ton T-Anchors only.

No side notches are provided on 2, 6 and 8-ton T-Anchors.

Use 8-10T P99 Recess and P91 Ring Clutch with FL319*.

Fleet-Lift System

P94H Fleet-Lift H-Anchor 2-Ton

The Dayton Superior Fleet-Lift H-Anchor (P94H) is unique in design simplicity. It offers exceptional strength for lifting and handling precast elements, yet can be used in panels as thin as 3". The P94H anchor can be easily preset in the form or "wet set" after the concrete has been poured. The H-Anchor is the strongest and most economical precast lifting anchor available for back-stripping. H-Anchors are available in plain and hot-dipped galvanized finish.

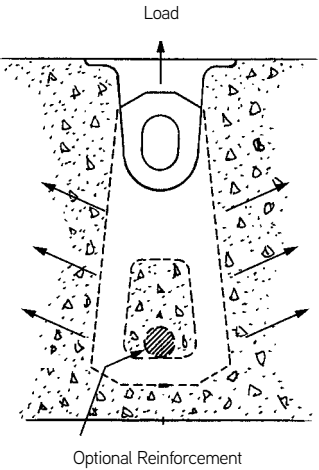
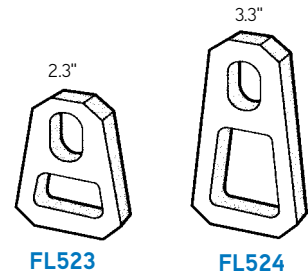

To Order:

Specify: (1) quantity, (2) name, (3) product code, (4) corrosion resistance, if required.

Example:

200, P94H Fleet-Lift H-Anchor, FL525, hot-dipped galvanized.

P94H Safe Working Load

Product Code	Load Range	Tension Load 4:1 SF	Tension with Reinforcement** 4:1 SF	Shear Load 4:1 SF	Minimum Edge Distance	Ultimate Mechanical Strength
FL523	2-ton	2,205 lbs.	2,900 lbs.	2,205 lbs.	8"	16,000 lbs.
FL524	2-ton	3,255 lbs.	4,000 lbs.	3,255 lbs.	10"	16,000 lbs.

Safe Working Load provides a factor of safety of approximately 4 to 1. Table is based on a minimum concrete compressive strength of 3,500 psi.

* When panel edge installation is required, use the H-Anchor or Two-Hole Anchor with a tension bar. Contact Dayton Superior Technical Assistance for minimum tension reinforcement.

** #4 x 12" long placed directly at centerline and against bottom of hole. See sketches at left.

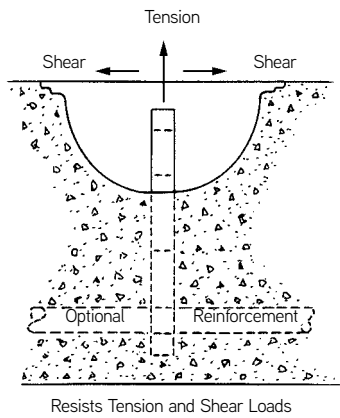

P94H Dimensions 2/3 Ton Ring Clutch System (2-Ton Anchor)

Product Code	A	B	C	D	Minimum Slab Thickness	Weight Each
FL523	1.25"	2.30"	.35"	.56"	3"	.28 lbs.
FL524	1.25"	3.30"	.38"	1.44"	4"	.36 lbs.

P94H H-Anchors are available in plain and hot-dipped galvanized.

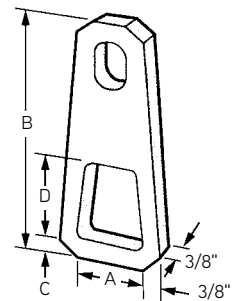

P94S Fleet-Lift S-Anchor

The Dayton Superior P94S Fleet-Lift S-Anchor is a high-strength, hot forged anchor that can be “wet set” or used with the optional T41 Plastic base in face-lift applications. When the P94S anchor is used with the Fleet-Lift high capacity ring clutches, safe working loads up to 20,000 pounds can be realized. See the table below for appropriate anchor lengths and concrete compressive strengths. P94S anchors are available in plain and hot-dipped galvanized.

To Order:

Specify: (1) quantity, (2) name, (3) product code, (4) finish.

Example:

400, P94S Fleet-Lift S-Anchors, FL505 with hot-dipped galvanized finish.



Type F



Type S

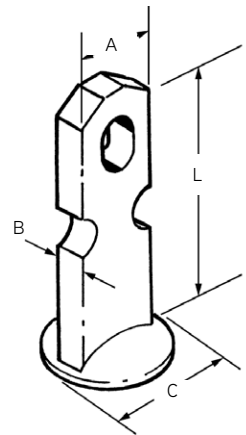

P94S Fleet-Lift S-Anchor

P94S Fleet Lift S-Anchor

Anchor Tonnage	Length (L)	Width (A)	Thickness (B)	Foot Diameter (C)	SWL Tension / Shear	Type
2.5	3-1/2"	1-5/16"	3/8"	1-1/2"	3,900	F/S
	4"				4,400	F/S
	5-1/2"				4,510	F
6	3-7/8"	1-1/2"	5/8"	1-7/8"	5,000	S
	4-1/8"				5,370	S
	4-7/8"				6,560	S
	5-1/8"				6,970	S
	5-7/8"				8,250	S
	6-1/8"				8,700	S
	6-7/8"				10,070	S
	7-3/8"				11,055	S
	7-7/8"				12,000	S
10	5-1/2"	2-5/8"	3/4"	2-7/8"	8,500	F
	7"				12,500	S
	10"				20,000	S

Safe working load is based on an approximate factor of safety of 4 to 1 in 3,500 psi normal weight concrete
 Use FLO62 Recess Member and FLO02S Ring Clutch (both 4-6T) with these anchors.
 Minimum edge distance is 1.5 × the anchor length.

P95F Fleet-Lift Flat Foot Anchor

The Dayton Superior P95F Fleet-Lift Flat Foot Anchor is a versatile anchor that can be used to back-strip and transport thin panels. This anchor may also be used to erect the panels.

The anchor's safe working load may be increased by adding four 18" lengths of #4 rebar as shown in the sketch.

To Order:

Specify: (1) quantity, (2) name, (3) product code.

Example:

200, P94F Fleet-Lift Flat Foot Anchor, FL058.

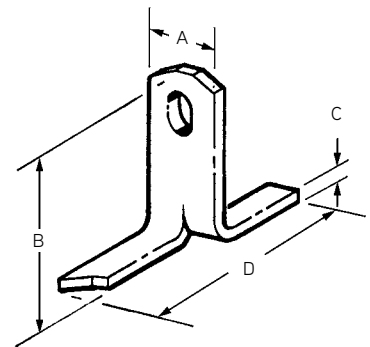
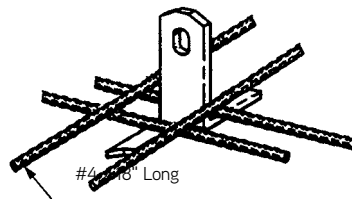

P95F Fleet-Lift Flat Foot Anchor

P95F Fleet-Lift Flat Foot Anchor (ton x length)	Product Code	Precast Concrete Min. Panel Thickness	Minimum Edge or Corner Distance	Shear Safe Working Load	Tension Safe Working Load	Shear Safe Working Load Reinforced	Tension Safe Working Load Reinforced	A	B	C	D
2-ton x 2-3/4" long	FL058	3-7/8"	5-1/2"	1,325 lbs.	1,325 lbs.	4,000 lbs.	4,000 lbs.	1-1/4"	2-3/4"	3/8"	4"
2-ton x 3-3/8" long	FL400	4-1/2"	6-3/4"	1,875 lbs.	1,875 lbs.	4,000 lbs.	4,000 lbs.	1-1/4"	3-3/8"	3/8"	4"
3-ton x 3-3/4" long	FL157	3-7/8"	7-1/2"	2,350 lbs.	2,350 lbs.	6,000 lbs.	6,000 lbs.	1-1/2"	3-3/4"	1/2"	4"

Safe working load is based on an approximate factor of safety of 4 to 1 in 3,500 psi normal weight concrete.

Fleet-Lift System

P95P Fleet-Lift Plate Anchor

The Dayton Superior P95P Fleet-Lift Plate Anchor is manufactured with a wide base designed to increase its pull-out capacity in concrete. The wide base allows the anchor to have an increased safe working load.

The design of the anchor, with its wide base, permits four #4 rebar, each 18" in length to be easily secured to the insert, as illustrated in the sketch. The addition of the rebar increases the safe working load of the anchor.

P95P anchors are available in plain or hot-dipped galvanized finish.

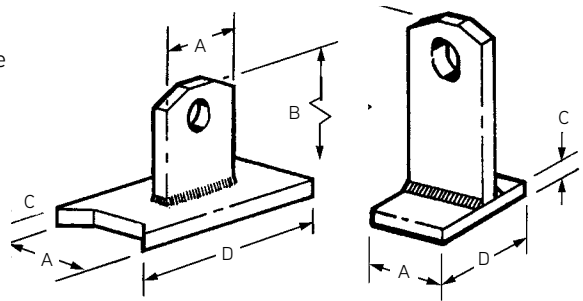

P95P Fleet-Lift Plate Anchor (FL043 only)

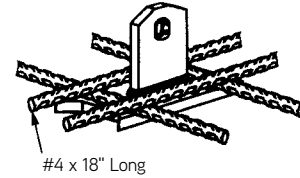

To Order:

Specify: (1) quantity, (2) name, (3) product code, (4) corrosion resistance, if required.

Example:

200, P95P Fleet-Lift Plate Anchor, FL847.

P95P Fleet-Lift Plate Anchor (ton x length)	Product Code	Precast Concrete Minimum Panel Thickness	Minimum Edge or Corner Distance	Shear Safe Working Load	Tension Safe Working Load	Shear Safe Working Load Reinforced	Tension Safe Working Load Reinforced	A	B	C	D
2-ton x 2-1/4" long	FL128	3-3/8"	4-1/2"	950 lbs.	950 lbs.	4,000 lbs.	4,000 lbs.	1-1/4"	2-1/4"	3/8"	4"
4-ton x 3" long	FL846	4-5/8"	5"	3,575 lbs.	3,575 lbs.	6,000 lbs.	6,000 lbs.	1-1/2"	3"	5/8"	3-3/8"
4-ton x 3-1/2" long	FL847	4-5/8"	7"	4,700 lbs.	4,700 lbs.	7,000 lbs.	7,000 lbs.	1-1/2"	3-1/2"	5/8"	3-3/8"
4-ton x 4-3/8" long	FL044	5-5/8"	8"	4,725 lbs.	4,725 lbs.	8,000 lbs.	8,000 lbs.	1-1/2"	4-3/8"	5/8"	4"
8-ton x 6-7/8" long	FL043	8-1/4"	13-5/8"	10,850 lbs.	10,850 lbs.	10,850 lbs.	10,850 lbs.	2-1/2"	6-7/8"	3/4"	3"

Safe Working Load provides an approximate factor of safety of 4 to 1 in 3,500 psi normal weight concrete. A minimum 3/4" of concrete is required below bottom of insert to achieve load.

P96 Fleet-Lift Two-Hole Anchor

The Dayton Superior P96 Fleet-Lift Two-Hole Anchor is always used in conjunction with the Dayton Superior P98T Tension Bar. The anchor has a bottom hole especially designed to accept the tension bar. Place the P98T Tension Bar through the bottom hole in such a manner that the ends of the tension bar are pointing downward. Fasten the tension bar tight against the bottom side of the hole.

The tension bar distributes the tension forces, developed from the lifting process, deep into the precast concrete. This allows the lifting of very thin and/or low concrete compressive strength panels.

Do not use the P96 Two-Hole Anchor in the following situations:

- Without a correct size and located tension bar.
- In the edge of thin panels where shear loads will be applied to the anchor.

To Order:

Specify: (1) quantity, (2) name, (3) product code, (4) corrosion resistance, if required. See P98T Fleet-Lift Tension Bar.

Example:

200, P96 Fleet-Lift Two-Hole Anchor, FL124.

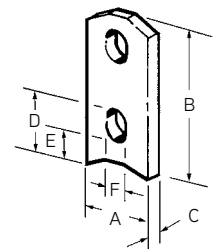

NOTE: Tension reinforcement must be used with Two Hole Anchors.

P96 Fleet-Lift Two Hole Anchor

P96 Fleet-Lift Two-Hole Anchor (ton x length)	Product Code	Tension Safe Working Load with Tension Bar	A	B	C	D	E	F
2-ton x 2-3/4" long	FL190	4,000 lbs	1-1/4"	2-3/4"	3/8"	9/16"	15/16"	9/16"
2-ton x 4" long	FL122	4,000 lbs	1-1/4"	4"	3/8"	3/4"	7/8"	9/16"
4-ton x 5-1/2" long	FL124	8,000 lbs	1-1/2"	5-1/2"	5/8"	7/8"	1"	11/16"
8-ton x 7" long	FL125	16,000 lbs	2-1/2"	7"	3/4"	1-3/16"	1-1/2"	1"

Safe working load is based on an approximate factor of safety of 4 to 1 in 3,500 psi normal weight concrete.

T110 Superior Lift System

The Dayton Superior T110 Superior Lift Insert is a face lift insert and consists of a forged foot anchor, 4-leg wire base and plastic void former. The insert utilizes the P91 Ring Clutch 8-12 T.

The T110 Superior Lift Inserts are shipped assembled, ready to go and are sized 1/8" less than the panel thickness. The T110 can also be shipped unassembled. WT 110 Steel Anchor can be used with single use Recess plug or P99 Reusable Recess Plug (8-10 T).

To Order:

Specify: (1) quantity, (2) name, (3) Panel Thickness, (4) bottom face exposed aggregate or formliner thickness.

Example:

150, T110 Superior Lift Inserts, 9" Panel with 1/2" formliner panel.

Structural Panel Thickness	Anchor Length	Product Code for Anchor Only	SWL Tension	SWL Shear
5"	3.625"	-----	6,875lbs	7,362lbs
5.5"	4.125"	126538	7,683lbs	7,958lbs
6"	4.625"	126539	8,490lbs	8,535lbs
6.25"	4.875"	126540	8,915lbs	8,793lbs
6.5"	5.125"	126541	9,298lbs	9,095lbs
7"	5.625"	126542	10,106lbs	9,641lbs
7.5"	6.125"	126544	10,914lbs	10,175lbs
8"	6.625"	126545	11,960lbs	10,748lbs
9"	7.625"	126548	12,000lbs	12,000lbs
10"	7.875"	126549	12,000lbs	12,000lbs

Safe working load provides approximate factor of safety of 4 to 1 in 3,500 psi normal weight concrete



T110 Superior Lift Anchor System

Fleet-Lift System

T275 Tilt-Up Anchor

The Dayton Superior T275 Tilt Up Anchor consists of a dual forged foot anchor assembled with a plastic recess plug and two plastic supports. The insert is a directional insert used parallel to the height of the panel. The T275 inserts are shipped assembled, ready to install and sized to the panel thickness.

Concrete Strength/ Safety Factor	Safe Working Load	Structural Panel Thickness	
		7-1/4" - 9"	9-1/4" - 12"
2,500 psi concrete and 2:1 SF	Tension	20,100 lbs	24,000 lbs
	Shear	24,000 lbs	24,000 lbs
3,000 psi concrete and 2:1 SF	Tension	22,050 lbs	24,000 lbs
	Shear	24,000 lbs	24,000 lbs
3,000 psi concrete and 2.5:1 SF	Tension	24,000 lbs	24,000 lbs
	Shear	17,639 lbs	24,000 lbs
3,000 psi concrete and 4:1 SF	Tension	11,024 lbs	15,718 lbs
	Shear	15,299 lbs	17,250 lbs
4,000 psi concrete and 4:1 SF	Tension	12,731 lbs	16,200 lbs
	Shear	17,250 lbs	17,250 lbs

Note: Mechanical Capacity of steel anchor is 69,000 lbs in shear and 64,800 lbs in tension



T275 Tilt-Up Anchor

To Order:

Specify: (1) Quantity, (2) Name, (3) Panel Thickness, (4) Product Code

Example:

150, T275 Tilt-Up Anchors, 7-1/4", 146553

P98S Fleet-Lift Shear Bar

The Dayton Superior P98S Fleet-Lift Shear Bar is designed and manufactured especially for use with Fleet-Lift Erection Anchors. It is a simple, easy to use, yet very efficient design that transfers shear forces from the erection process deeper into the edge of a precast concrete panel. It is stronger and less expensive than a shear bar fabricated from reinforcing steel.

The design of the shear bar allows it to fit over the top edge of an erection anchor. It is placed in the top notch and secured so that it bears tightly against the bottom of the notch. Accurate placement of the shear bar provides for spall-free edge lifts.

The P98S Shear Bar is available to fit 2, 4 and 8-ton Fleet-Lift Erection Anchors. Available in plain or hot-dipped galvanized finish.

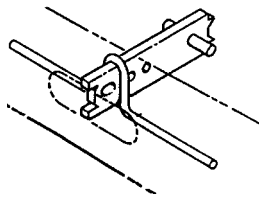

Typical Shear Bar Application

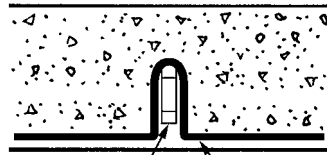

Erection Anchor Shear Bar

Top View

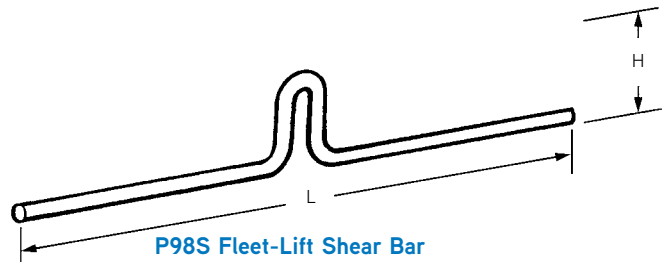

P98S Fleet-Lift Shear Bar

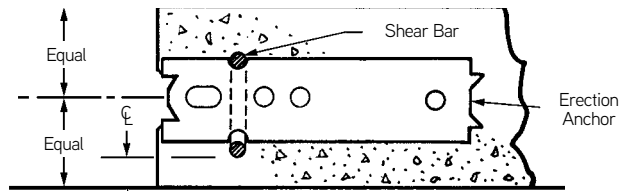

Minimum 3/4" Concrete Cover

Section View

Fleet-Lift System

To Order:

Specify: (1) quantity, (2) name, (3) product code, (4) corrosion resistance, if required.

Example:

200 P98S Fleet-Lift Shear Bar, FL141, hot-dipped galvanized.

Anchor Tonnage	Product Code	Shear Bar Diameter	Minimum Panel Thickness	Dimensions	
				H	L
2 to 3-ton	FL140	1/2"	4"	2-1/2"	13-7/8"
4 to 6-ton	FL141	1/2"	5-1/2"	3-5/16"	13-7/8"
8 to 10-ton	FL142	1/2"	7-1/2"	4-15/16"	13-7/8"

P98T Fleet-Lift Tension Bar

The Dayton Superior P98T Fleet-Lift Tension Bar is used with various Fleet-Lift Anchors to provide a simple, inexpensive method of distributing tension forces (lifting) deep into a precast member.

Anchor Tonnage	Tension Bar (Grade 60)	L=Overall Length of P98T Tension Bar		
		3,000 psi	4,000 psi	5,000 psi
1-ton or 2-ton	#3	32"	28"	26"
3-ton or 4-ton	#4	44"	38"	34"
6-ton or 8-ton	#6	66"	56"	50"
10-ton	#8	110"	95"	85"

L = Overall length of tension bar based on concrete compressive strength at time of lift.

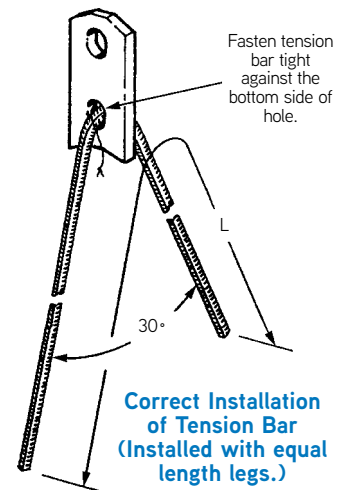

Correct Installation of Tension Bar (Installed with equal length legs.)

P99 Fleet-Lift Reusable Recess Plug

The Dayton Superior P99 Fleet-Lift Reusable Recess Plug is molded from an elastomeric thermal-set urethane for multiple reuse.

Embedded in the recess plug is a stainless steel stud that securely captures a Fleet-Lift Anchor, providing a positive connection to the form during the placement of concrete. Attachment to the form is accomplished with a P100 Holding Rod and P101 Fleet-Lift Holding Plate.

P99 Recess Plugs are resistant to heat and form release agents encountered in a precast plant.

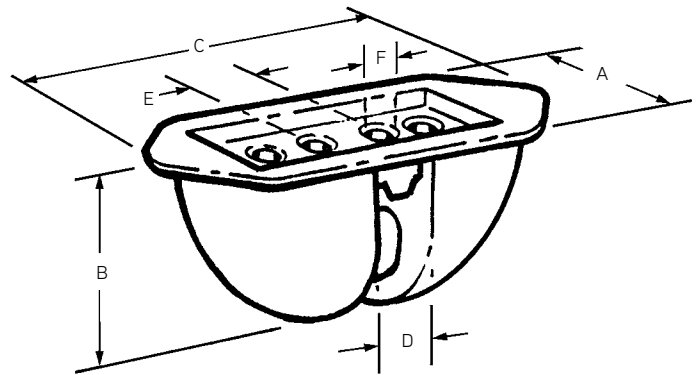
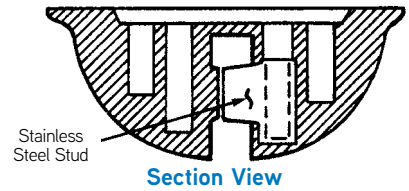

P99 Fleet-Lift Reusable Recess Plug

To Order:

Specify: (1) quantity, (2) name, (3) product code.

Example:

200, P99 Fleet-Lift Reusable Recess Plug, FL062.

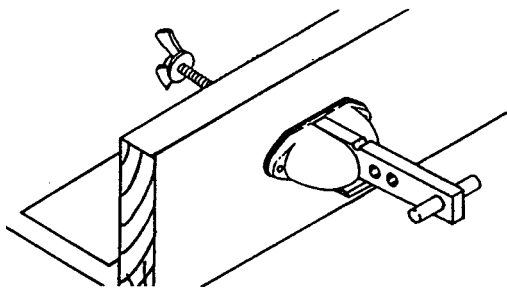

Typical Reusable Recess Plug Application

Anchor Tonnage	Product Code	A	B	C	D	E	F
1-ton	FL051	1-11/16"	1-3/4"	4-1/16"	3/16"	1-3/16"	3/8"
2-3 ton	FL200	1-11/16"	1-3/4"	4-1/16"	3/8"	1-3/16"	3/8"
4-6 ton	FL062	2-1/8"	2-5/16"	5-3/16"	5/8"	1-11/32"	3/8"
8-12 ton	FL121	3-1/8"	3-5/16"	7-13/16"	3/4"	1-31/32"	3/8"

Note: Recess Plug style FL051 is used with the 1-ton L-Anchor and 2-ton Ring Clutch combination ONLY.

P100 Fleet-Lift Holding Plate and P101 Fleet-Lift Holding Rod

P100 Fleet-Lift Holding Plate

Anchor Tonnage	Product Code	A	B	C
1-ton	FL160	5/8"	2-3/4"	10mm
2-3 ton	FL160	5/8"	2-3/4"	10mm
4-6 ton	FL144	1-1/4"	3-3/8"	10mm
8-10 ton	FL111	1-3/4"	4-7/8"	12mm

P101 Fleet-Lift Holding Rod

Anchor Tonnage	Recess Plug Material	Product Code	Standard Rod Length	Thread Diameter and Type
1, 2, 4, 6, 8 and 12-ton	Urethane	FL131	6"	3/8" Coil
1, 2, 4, 6, 8 and 12-ton	Steel	FL131C	6"	1/2" Coil

Note: Holding Rod may be special ordered in longer lengths.

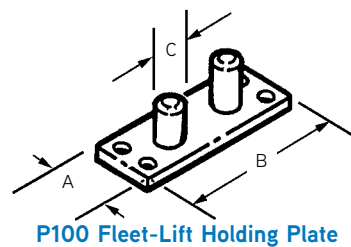

P100 Fleet-Lift Holding Plate

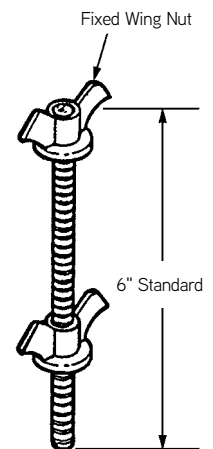

P101 Fleet-Lift Holding Rod

To Order:

Specify: (1) quantity, (2) name, (3) product code.

Example:

200, P100 Fleet-Lift Holding Plates, FL144.

Fleet-Lift System

Installation and Removal of Anchors and Reusable Recess Plugs

Installing an Anchor in the Recess Plug: A) Open the slot of the recess plug by placing a holding rod or screwdriver into an outside hole and squeeze the recess “open.” (B) Place the anchor over the steel stud and close the recess plug. The assembly is ready for installation.

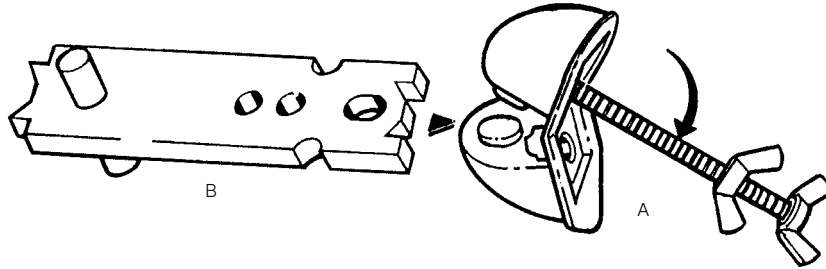

Attaching the Assembly to the Form: A) Place the assembly against the form and position over the predrilled hole. (B) Insert the 3/8" holding rod through the hole and thread into the recess plug. (C) Pull the assembly tight to the form by firmly tightening the wing nut on the holding rod.

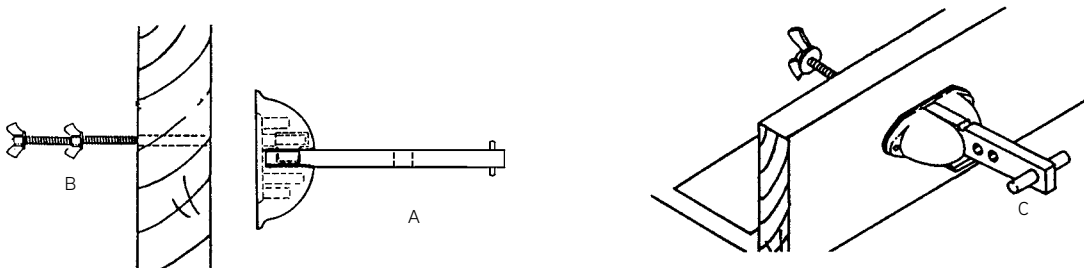

Attachment Using a Holding Plate: A) Position and attach the holding plate to the form. B) Slide the anchor assembly over the holding plate studs and firmly against the form. (C) Installation is complete.

Note: The holding plate can be used to hold the recess plug/insert assembly in the closed position to facilitate working the anchor into fresh concrete (wet setting). It is recommended that the back of the recess plug be covered with tape to protect it from being filled with concrete. Be sure to vibrate to properly consolidate the concrete around the anchor. To strip, simply remove the tape and/or cover/patch and pry the holding plate out of the recess plug with a blade screwdriver or similar tool.

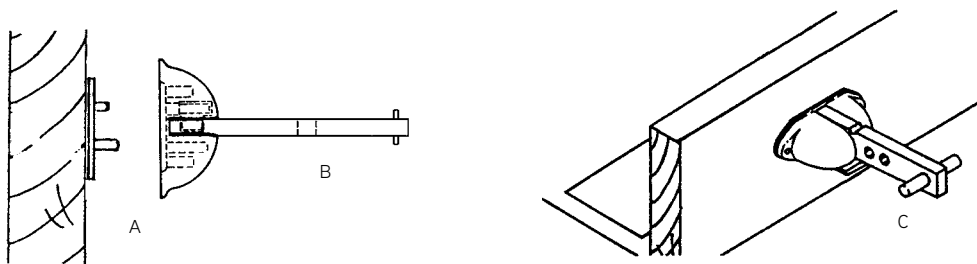

Removing the Recess Plug from the Concrete: A) After the back of the recess plug is exposed, insert a steel rod or screwdriver into the half of the recess plug opposite the threaded stud and rotate it to loosen that half of the recess plug. (B) After the first half of the recess plug has been loosened, use the holding rod in the other side in a “scissor” motion to free the recess plug.

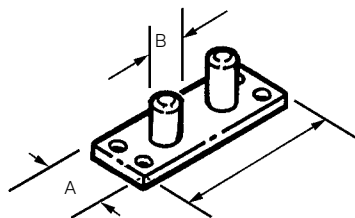

P99C Fleet-Lift Cast Steel Recess Plug

The Dayton Superior P99C Fleet-Lift Cast Steel Recess Plug is designed for high reuse, high curing temperatures and cold weather applications. The recess Plug uses a Steel Wedge (P102) through the anchor eye to securely hold the anchor in place. A Foam Strip (P103) fits over the head of the anchor to prevent concrete from entering the void.

The recess plug/anchor assembly is secured to the form work with the 1/2" diameter Holding Rod (P101) or simply nailed to the form. Recess plug, steel wedge and foam insert are sold separately.

Fleet-Lift System

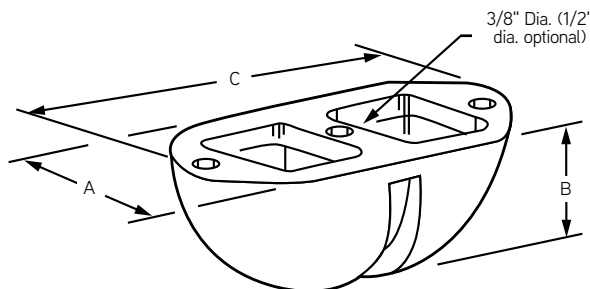

P99C Fleet-Lift Cast Steel Recess Plug

P99C Fleet-Lift Cast Steel Recess Plug

Anchor Tonnage	Product Code	A	B	C
2-3 ton	FL078	1-7/8"	1-3/4"	4"
4-6 ton	FL100	2-3/8"	2-3/8"	5-3/8"
8-12 ton	FL015	3-3/8"	3-3/8"	7-3/8"

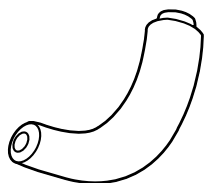

P102 Fleet-Lift Steel Wedge

P102 Steel Wedge

Anchor Tonnage	Product Code
2-3 ton	FL017
4-6 ton	FL084
8-12 ton	FL085

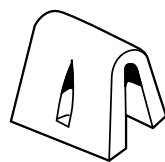

P103 Fleet-Lift Foam

P103 Foam

Anchor Tonnage	Product Code
2-3 ton	FL087
4-6 ton	FL069
8-12 ton	FL091

To Order:

Specify: (1) quantity, (2) name, (3) product code.

Example:

200, P99C Fleet-Lift Cast Steel Recess Plug, FL100.

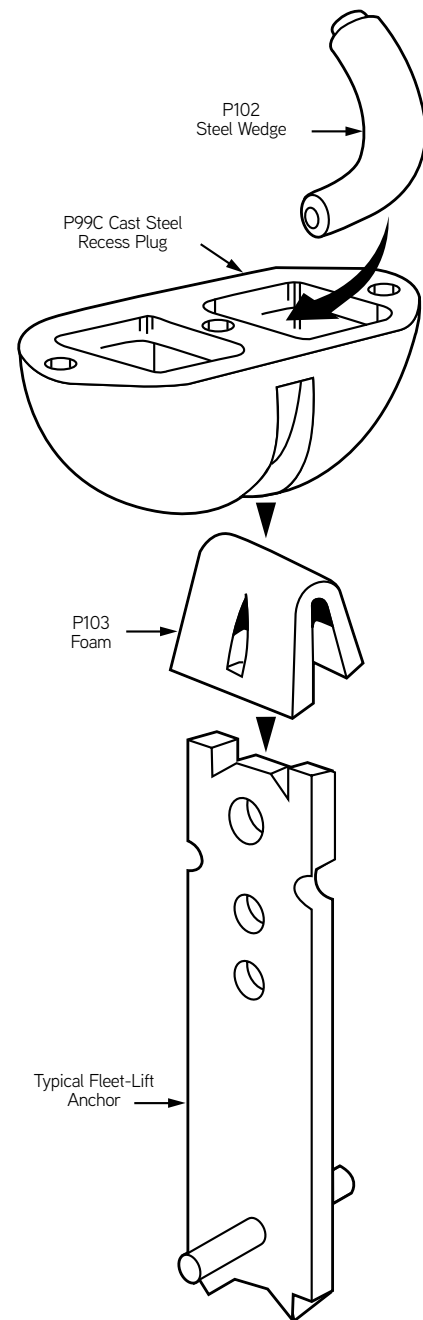

P99C Fleet-Lift Cast Steel Recess Plug Assembly Sequence

Installation and Removal of the Fleet-Lift Cast Steel Recess Plug

Installing the Cast Steel Recess Plug to an Anchor: A) Place the foam strip over the top of the anchor. (B) Place the anchor and foam into the recess slot. (C) Slide the curved steel wedge into the top of the recess plug and through the anchor's "eye" and wedge tightly.

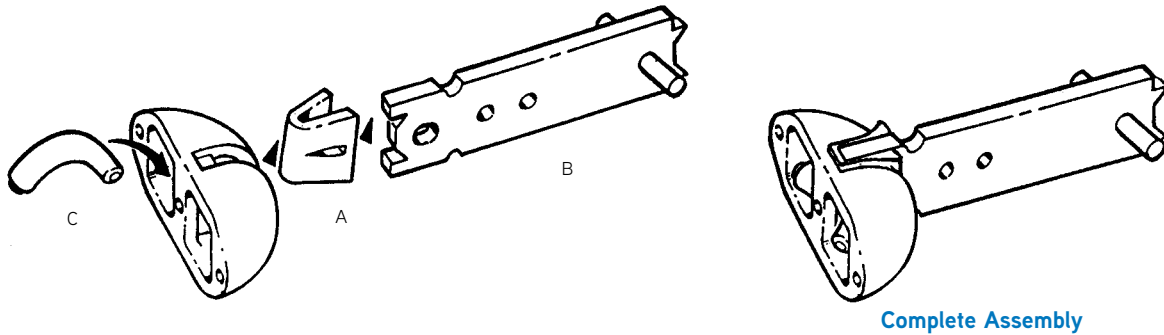

Attaching the Recess Plug/Anchor Assembly to the Form: A) Place the assembly over the predrilled hole. (B) Insert a holding rod through the hole and thread it into the recess plug. Tighten the holding rod against the anchor with the "fixed" wing nut. (C) Tighten the assembly against the form with the "free-running" wing nut.

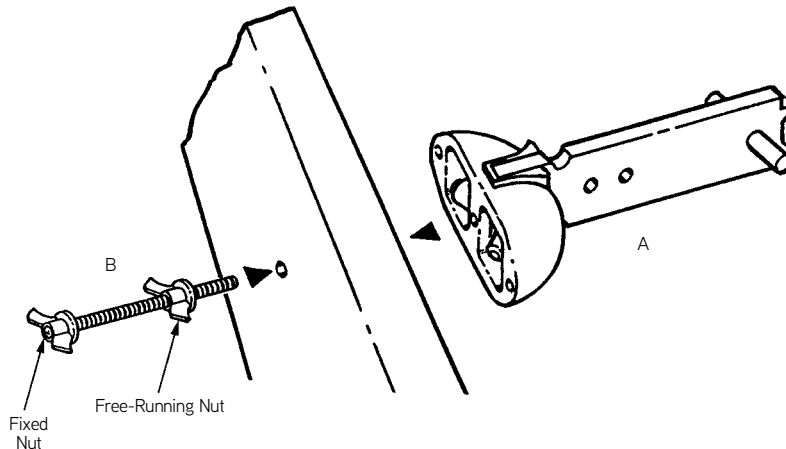

Removing the Cast Steel Recess Plug: A) Remove the holding rod from the recess plug. (B) Remove the form. (C) Remove the steel wedge by tapping on the small end with a hammer. (D) Thread the holding rod back into the recess plug and tighten until it pushes the recess out of the void.

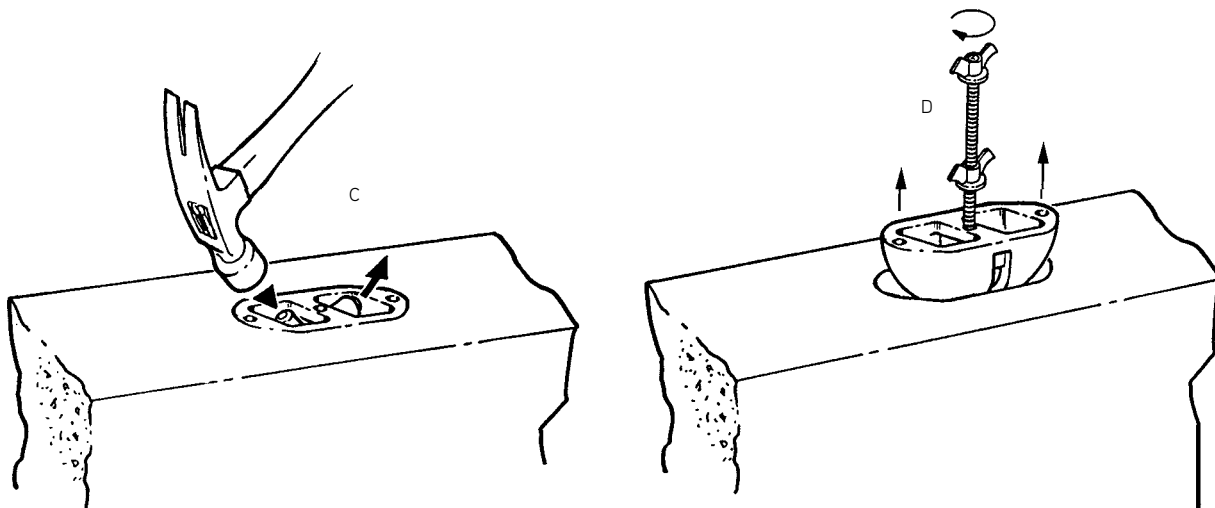

P99D Fleet-Lift Disposable Recess Plug (PVC)

The Dayton Superior P99D Fleet-Lift Disposable Recess Plug can be used to preset Fleet-Lift face-lift or edge-lift anchors or can be used to “wet set” P94 Anchors. The Cover/Patch fits tightly onto the recess plug to fully protect the unit. The Cover/Patch is concrete gray in color and can be used as a patch over the recess opening for temporary or permanent cover.

Recess Plug Components:

The Disposable Recess Plug can be ordered in sets consisting of a body with a preinstalled clip and a lid, or as individual pieces. This gives the system the versatility to meet your requirements without having to order parts that are not needed.

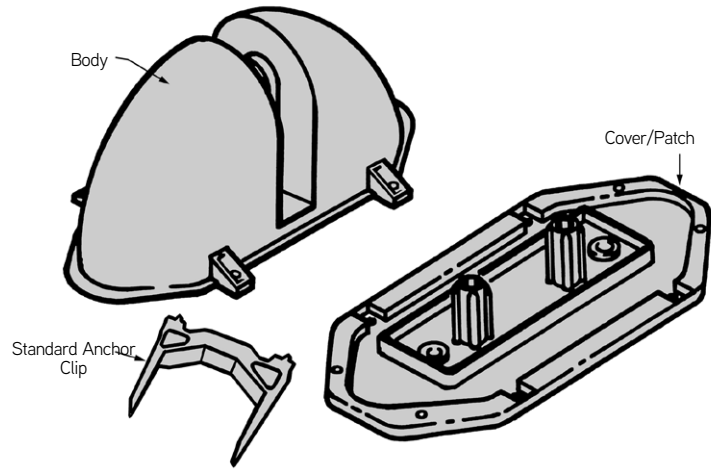

Disposable Recess Set

To Order:

Specify: (1) quantity, (2) name, (3) complete sets or individual part, (4) product code.

Example:

200, P99D Fleet-Lift Disposable Recess Plug Cover/Patches, FL067S.

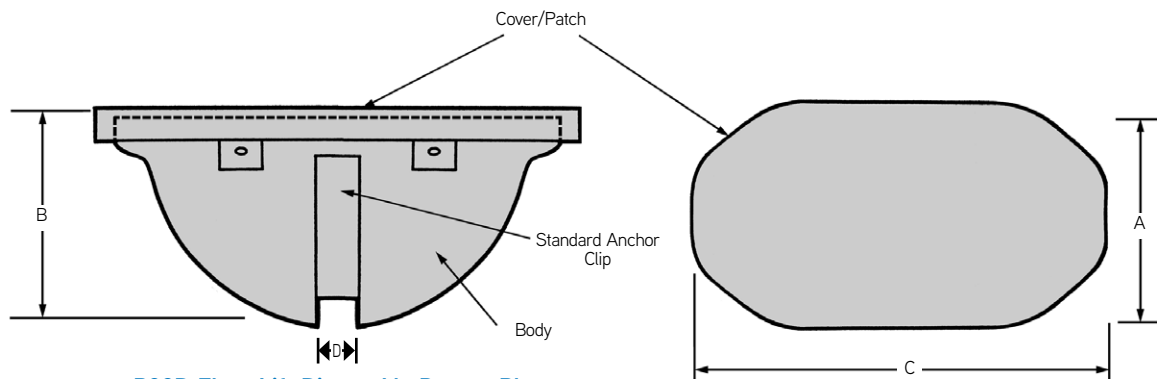

P99D Fleet-Lift Disposable Recess Plug

Anchor Tonnage	Product Description	Product Code	A	B	C	D
1, 2 and 3-ton	Body	FL066B	—	—	—	3/8"
	Lid	FL066L	2-7/16"	—	4-1/4"	—
	Set	FL066S	2-7/16"	2"	4-1/4"	—
4 and 6-ton	Body	FL067B	—	—	—	5/8"
	Lid	FL067L	2-7/8"	—	5-1/2"	—
	Set	FL067S	2-7/8"	2-1/2"	5-1/2"	—
8, 10 and 12-ton	Body	FL068B	—	—	—	3/4"
	Lid	FL068L	3-7/8"	—	8-5/16"	—
	Set	FL068S	3-7/8"	3-1/2"	8-5/16"	—

Installation of P99D Disposable Recess Plug and Erection Anchors

Installing an Erection Anchor in a Disposable Recess Plug:

(A) Remove the clip from the recess plug. The clip will not be used with the erection anchor. (B) Open the body of the recess plug enough to allow the anchor to slide into the recess plug. (C) Close the recess plug around the anchor. Recess plug/anchor assembly is completed.

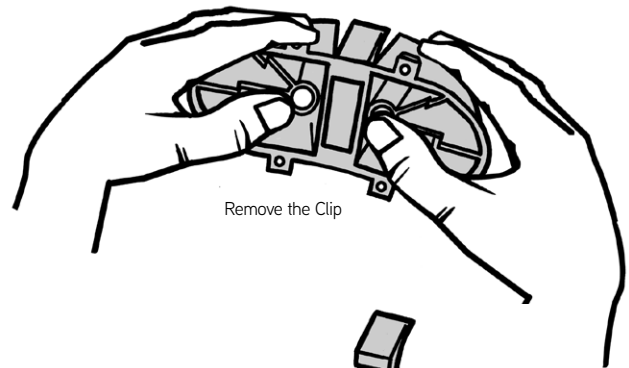

Attaching the Erection Anchor/Recess Plug to the Form:

Four methods are displayed in the sketches:

1. Edge Installation – Two Step Method – (A) Nail the cover/patch to the edge form for position. (B) Push the anchor/recess assembly onto cover/patch's studs until fully seated and nail the recess plug to the form.
2. Edge Installation – One Step Method – Place the anchor/recess plug assembly (with cover/patch attached) in the desired position and nail the assembly to the edge form.
3. Edge Installation – Double-Faced Tape – Place double-faced tape on the cover/patch and press the assembly onto the edge form in the desired position.
4. Edge Installation – With Holding Rod – (A) Drill out and remove one of the studs on the cover/patch. (B) Install the cover/patch on the recess plug body with the drilled-out hole over the threaded insert in the recess plug body. (C) Place the recess plug/anchor assembly over a predrilled hole in the edge form. (D) Firmly attach the assembly to the edge form with a 3/8" holding rod.

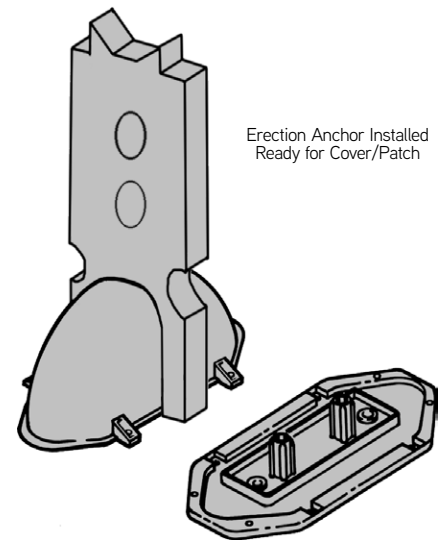
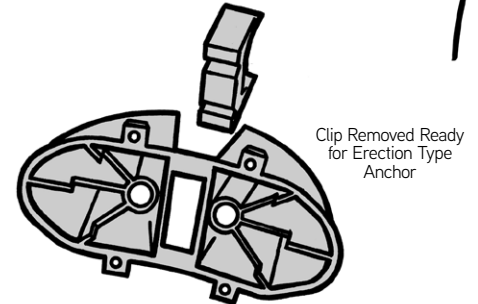

1) Edge Installation TwoStep

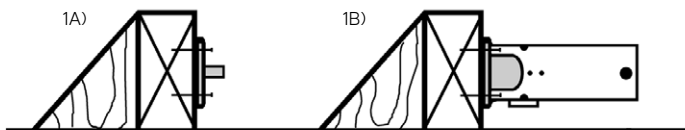

2) Edge Installation OneStep

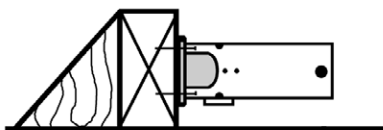

3) Edge Installation Double-Faced Tape

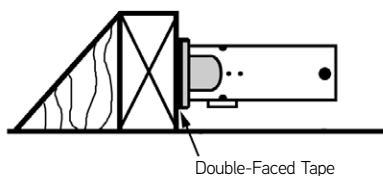

4) Edge Installation With Holding Rod

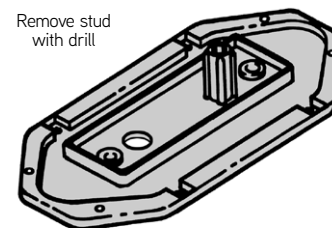
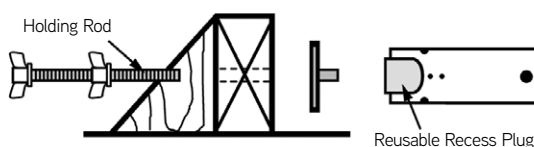

Installation of P99D Disposable Recess Plug and Standard Anchors

Installing Standard Anchors in the Disposable Recess Plug:

To install standard, non-erection head anchors, open the Dayton Superior P99D Disposable Recess Plug just enough to allow the anchor to be inserted fully into the body of the recess plug. Do not excessively open the body to avoid damaging the recess plug. Note that the anchor clip fits snugly against the anchor to seal out any concrete leakage. Snapping the cover/patch onto the recess plug completes the installation.

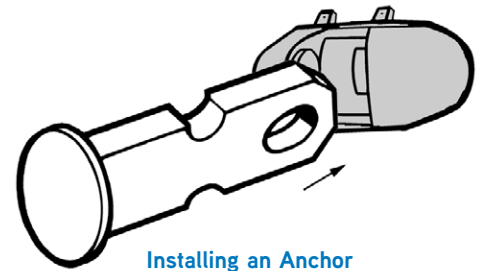

Installing an Anchor

Setting Standard Anchors with the Disposable Recess Plug:

The recess plug/anchor assembly can be set in position in a variety of methods: (1) by nailing it to a support beam and suspending it above the surface of the concrete, (2) nailed or double-faced taped to the form face or (3) wet set. Wet setting is accomplished by nailing or taping the assembly to a small template board and then working the assembly down into the freshly poured concrete. Light vibration is usually needed to ensure good bond around the anchor. A properly placed anchor will have the cover/patch slightly below the surface of the concrete. This will facilitate screeding operations and will aid in locating the recess after curing.

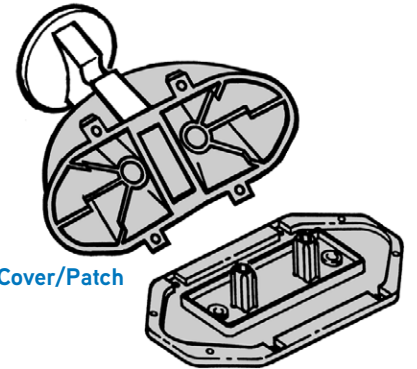

Install Cover/Patch

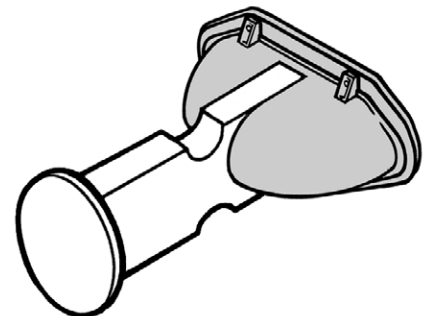

S-Anchor Installed

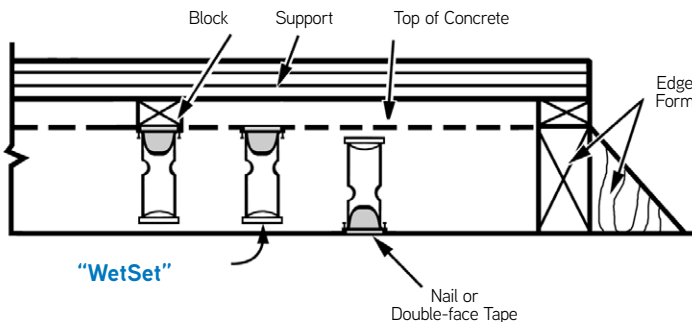

Disposable Recess Plug Removal:

(A) To remove the cover/patch – Place a blade screwdriver in the center of cover/patch’s side and carefully dislodge and remove the cover/patch. (B) To remove the recess plug’s body – Insert a screwdriver or similar tool into each round hole in the recess plug and rotate the tool to remove the body. The anchor clip may remain in the recess and require a separate removal.

Remove recess body by inserting screwdriver into **each** round hole and rotate to release. Remove body.

Note: Body clip may remain in recess and require separate removal.



P99D Temporary Cover/Patch Installation

The Dayton Superior P99-D Cover/Patch can be used as a temporary cover to keep sand, rain, snow, debris, etc., out of the recess. Under normal precast plant yard conditions, it will stay in place without adhesive.

When planning to use the cover/patch as a temporary cover, be careful when removing the cover to avoid damage. Simply replace the cover/patch into the formed recess, flush with the surface of the concrete. A silicone adhesive may be used on the inner rim of the recess to prevent water from entering the recess.

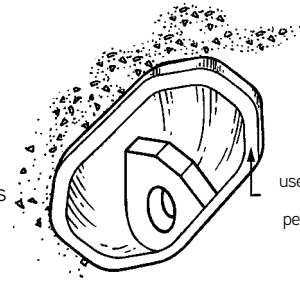

Support Rim:
use silicone adhesive on this area for permanent or water tight patch

Permanent Cover/Patch Installation

When used as a permanent patch, the cover/patch eliminates the need to grout and will protect the anchor from the environment. The light gray color of the unit will blend with most normal concrete, or it can be painted to closely match other color applications.

When anticipating the use of the cover/patch as a permanent application, be careful during removal to protect the integrity of the concrete around the perimeter of the recess. An application of a silicone or other type adhesive to the inner rim of the recess will seal out the elements or other contaminants. If the recess plug/anchor assembly was installed flush with the concrete surface, the cover/patch will be flush in its permanent position. Future access to the anchor is easily accomplished by removing the cover as described earlier.

Additional cover/patches may be purchased separately, if required.

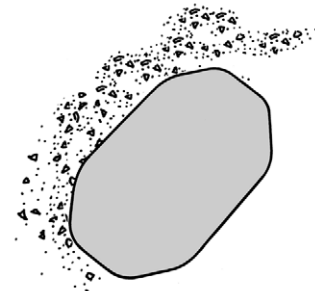

Reinstalled as a temporary or permanent patch

Protective Cap for Reusable Recess Plugs

The cover/patch can be used as a protective cap for the reusable recess plug. This will protect the recess plug and will eliminate the use of duct tape to cover the back of the recess plug. After installing the anchor in the recess plug, snap the cover/patch onto the recess plug. The cover/patch can be ordered separately for this purpose and can be used and reused many times in this type of installation.

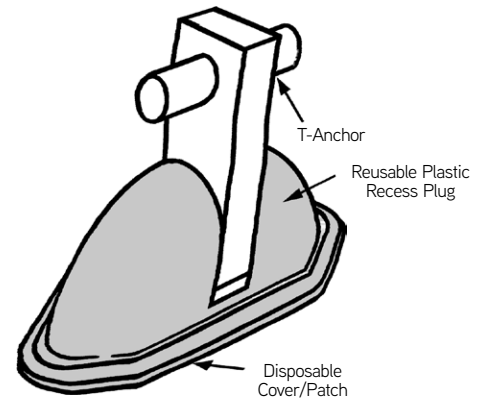

T-Anchor

Reusable Plastic Recess Plug

Disposable Cover/Patch

P99P Fleet Patch

The Dayton Superior P99P Fleet Patch is a durable plastic patch designed to quickly cover 2-6-ton Fleet-Lift setting plug recesses. The P99P patch is fabricated from an additive stabilized polypropylene to maintain the patch's slightly convex shape. The convex shape helps to keep a constant gripping pressure after installation. The patch is supplied in a concrete gray color with a matte finish that allows subsequent painting, if desired.

Fleet Patch Advantages:

- Special shape-holding composition
- Fast, one-piece "push-on" installation
- Paintable concrete gray matte finish
- Full eight (8) inch diameter
- Weather and chemical resistant
- Self adjusting grippers

The P99P Fleet Patch is a high quality, one piece plastic patch that is easy to install and maintain. It will provide a quick and economical solution to covering Fleet-Lift anchor recesses.

Typical P99P Fleet Patch Installation:

- 1) Start the patch grippers on the top edge of the anchor
- 2) Push the patch onto the anchor and flush with the concrete

Note: The P99P Fleet Patch will not prevent corrosion or rusting of an embedded anchor that is subject to wet conditions. Spraying the anchor with a corrosion resistant compound and applying a bead of silicone around the underside of the patch will help prevent moisture penetration.

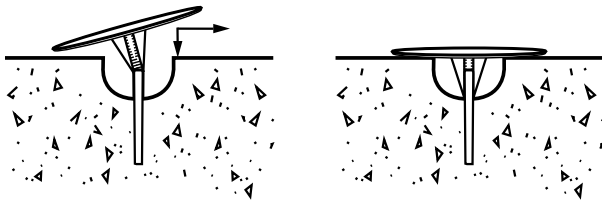

P99P Fleet Patch

Fleet Patch

Sales Category	Product Code	Weight for 100
P99P	FL612	24 lbs.

To Order:

Specify: (1) quantity, (2) name, (3) product code.

Example:

200, P99P Fleet Patch, FL612.

P100M Fleet-Lift Magnetic Plate

The Dayton Superior P100M Fleet-Lift Magnetic Plate eliminates the need for drilling setting-bolt holes in steel forms. Installed into a rubber base is a set of strong, reliable magnets. These magnets, along with an attachment stud and setting screw, work together to hold a Fleet-Lift anchor tightly in position during the placement of concrete.

The P100M Magnetic Plate is available in three sizes to fit the three P99 Fleet-Lift Recess Plugs.

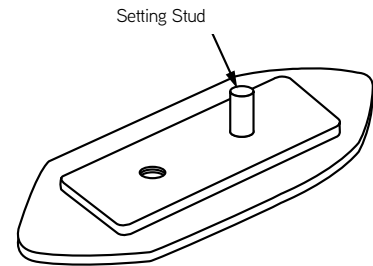

P100M Fleet-Lift Magnetic Plate

P100MS Setting Screw

Provided with 3/8" coil threads and used to attach the magnetic setting plate to the P99 Recess Plug, this unit has either a slot or hex in the head.

Use the 1-1/2" long setting screw with the 1, 2 and 3-ton system and the 2-3/8" long setting screw with both the 4 to 6-ton and the 8 to 10-ton systems.



P100MS Setting Screw

P100M Fleet-Lift Magnetic Plate Installation

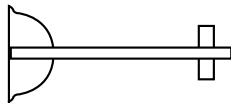

1. Attach Fleet-Lift Anchor to recess plug.

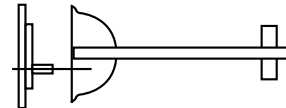

2. Push recess plug onto setting stud of the magnet using the non-threaded middle hole.

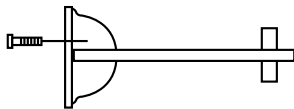

3. Place the P100MS Setting Screw through the hole in setting plate, securing setting plate tightly to recess plug.

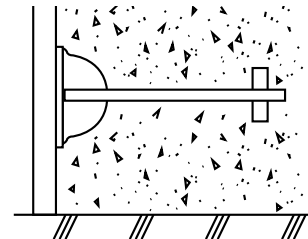

4. Carefully set complete anchor assembly into proper position in the form.

P104F Fleet-Lift One Piece Magnetic Recess

The Dayton Superior P104F One Piece Magnetic Recess allows installation of the Fleet anchors in a metal face form using a one piece rubber recess with magnets imbedded in the top of the recess. Available in 2T, 4T and 8T products.



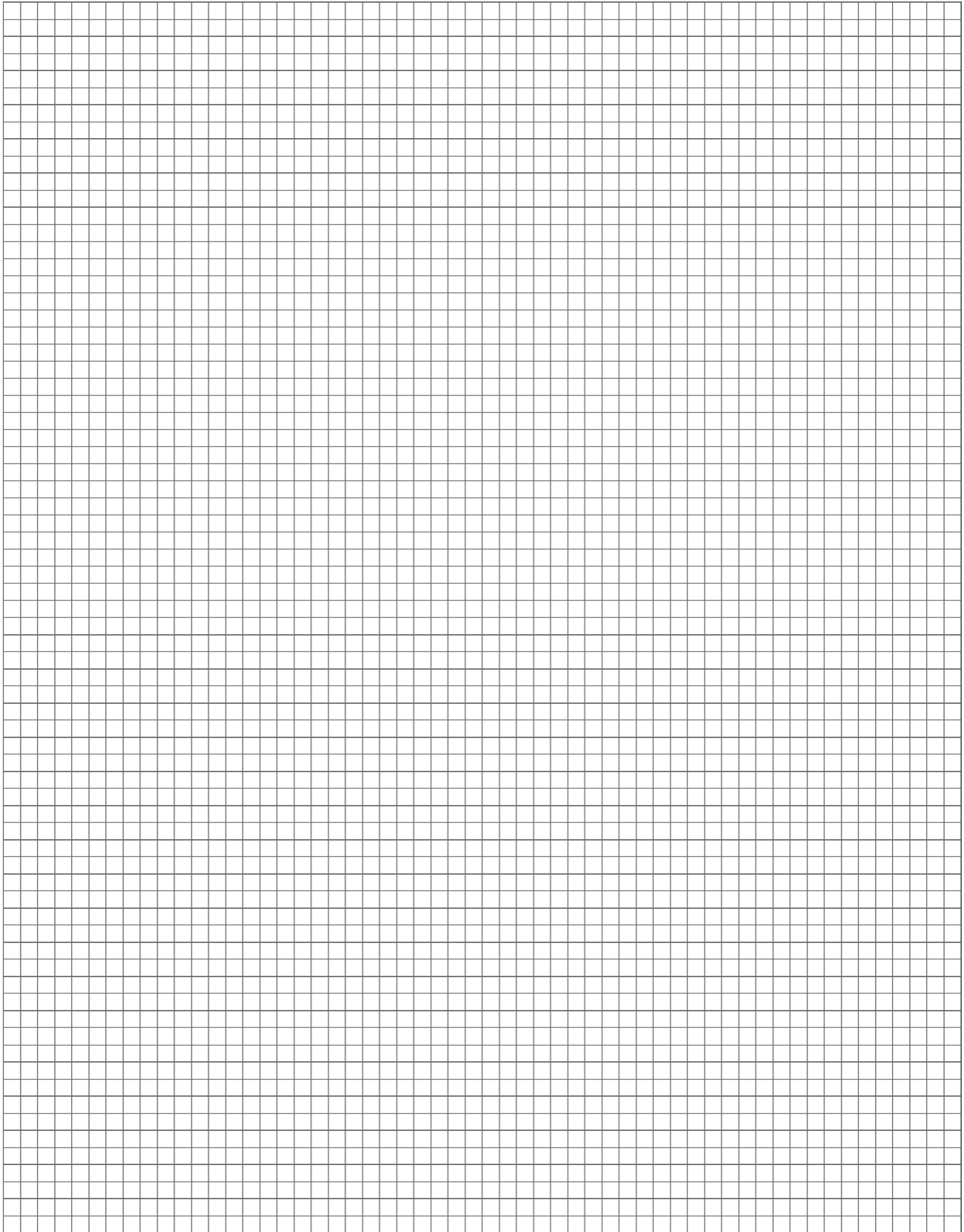

Utility Anchor System

The Dayton Superior Utility Anchor System is designed to economically simplify the lifting and handling of precast concrete elements. Its economics, ease of use and versatility will be a welcome addition to your precast operations.

Key Advantages

- High strength – up to 24,000 lbs. SWL
- No special lifting hardware required
- Uses a standard hook or clevis
- Easy to install and use
- Utilizes reusable 90° and 45° polyurethane recess plugs
- Eliminates “through holes” in the precast element
- An economical and versatile system – applicable to any precast concrete element

Added Benefit

Utility contractors can use the utility anchor effectively as a pulling iron. When used as a pulling iron, the safe working loads may be increased by 33%, based on the use of a 3 to 1 factor of safety.

The design of the Dayton Superior Utility Anchor Utility System assures the precaster of an economical, user-friendly system for lifting and handling precast concrete elements.

Utilize the Utility Anchor System to:

- Remove precast elements from their forms
- Handle in the precast yard
- Load for shipment
- Unload and place at the job site

The precaster is able to do it all without the need for any special lifting equipment or hardware. Simply use a standard hook or shackle to connect slings to the utility anchor for a safe lift.

The Utility Anchor System uses a polyurethane recess plug to create a void in the concrete. The concrete void created for the P75H utility anchor is sufficiently large to accept the following:

1. 6-ton Grade 8 alloy hook or
2. 7-ton forged alloy shackle

For the P75S Utility Anchors:

3. 15-ton cast/alloy hook or
4. 15-ton forged alloy shackle

DO NOT use larger hooks or shackles; they will apply additional and unintended loads to the utility anchor and could cause a premature failure of the concrete or anchor.

Anchor Placement

Placement of the Utility Anchor is dependent on the structural shape of the precast element. Utility anchors are not designed for thin edge installation. Always maintain minimum edge distances. For special conditions, contact the nearest Dayton Superior Technical Service Department for assistance.

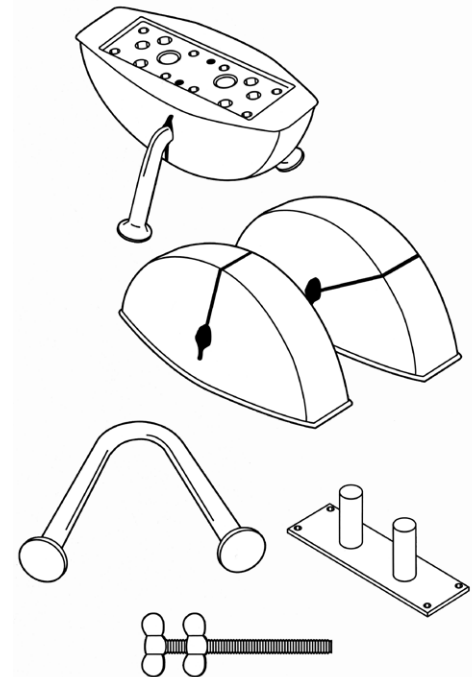

Utility Anchor
Lifting System

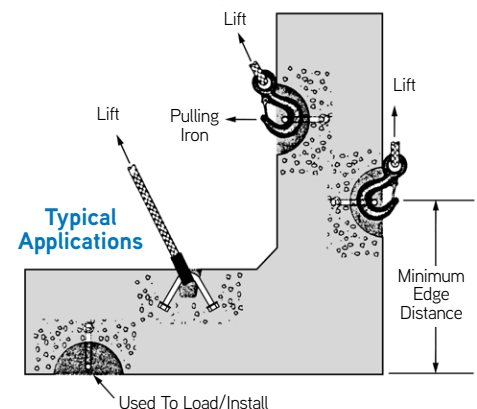

P72 Block Wall Lifting Anchor

PRODUCT DESCRIPTION

P72 Block Wall Lifting Anchors are made of 5/8" diameter galvanized carbon steel wire..

PRODUCT APPLICATION:

P72 Block Wall Lifting Anchors are designed for lifting and handling of Stone Strong retaining wall blocks.

PRODUCT FEATURES AND BENEFITS:

- Made with Hot-Dipped Galvanized finish per ASTM A153
- Safe Working Load is 7,150 lbs based on ultimate anchor failure and 4,500 lbs based on anchor deflection with 4:1 Safety Factor in 4,000 psi normal weight concrete
- Ultimate mechanical strength of P72 Anchor is 28,850 lbs
- P72 Anchor is 11.5" wide and 16.5" deep



RELATED PARTS:

- P75R

Product Code	Description	Weight
145552	16.5" HOT DIPPED GALV.	3.6 LB

To Order:

Specify: (1) Quantity, (2) Name, (3) Product Code.

Example:

25, P72 Block Wall Lifting Anchor, 145552.

Utility Anchor Lifting System

P73SL Thin Slab Utility Anchor

PRODUCT DESCRIPTION:

The Dayton Superior Thin Slab Utility Anchor is hot forged from carbon steel. The formed head provides for lifting hardware, while a disc-shaped foot is embedded in the concrete. Available in two sizes.

Due to the anchor being forged, it does not depend on welds or thread engagement to develop its safe working load. Forging provides maximum safety with its advantageous material structure. This allows the anchor to easily meet the OSHA requirement of 4 to 1 factor of safety.

PRODUCT APPLICATION:

The P73 is installed in thin slab Precast concrete for tension lifting applications

PRODUCT FEATURES AND BENEFITS:

- Plain or galvanized finishes available, meets nonrusting requirements
- Can be placed in 4" and greater wall thicknesses (T)
- Forged design creates up to 33% higher load capacity than stamped anchors; can reduce the number of anchors required
- Forged material minimizes rust and can result in eliminating galvanizing requirement for some projects
- No special lifting equipment or hardware required. Uses standard Crosby Hook or Clevis
- Anchor ultimate mechanical strength is 40,000 lbs.

INSTALLATION:

The P73SL Thin Slab Utility Anchor is set in the form using the P76L Void Former.

RELATED PARTS:

- P76L Void Former – 139832
- Magnetic Setting Plate – 143067
- Holding Rod – FL131C



Utility Anchor Lifting System

To Order:

Specify: (1) Quantity, (2) Name, (3) Product Code, (4) Finish

Example:

25, P73SL Thin Slab Utility Anchor, 139528, Galvanized

P73SL Thin Slab Utility Anchor Tension Load

Product Code	Finish	Length (L)	Width (W)	Panel Thickness (T)			
				4"	5"	6"	8"
139528	Galvanized	4.5"	3.00"	3,636 lbs	4,129 lbs	5,820 lbs	5,457 lbs

Safe Working Load provides an approximate factor of safety of 4:1 in 3,500 psi normal weight concrete.

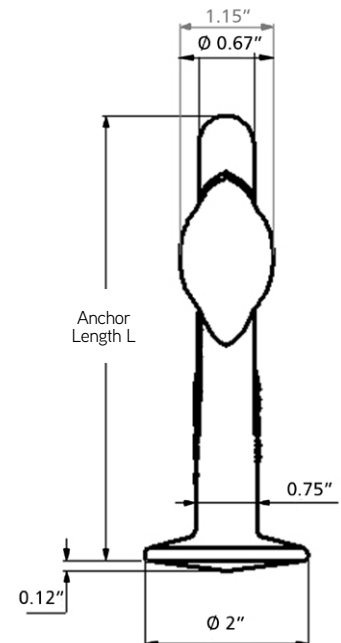
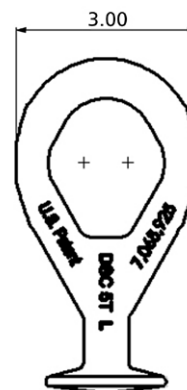
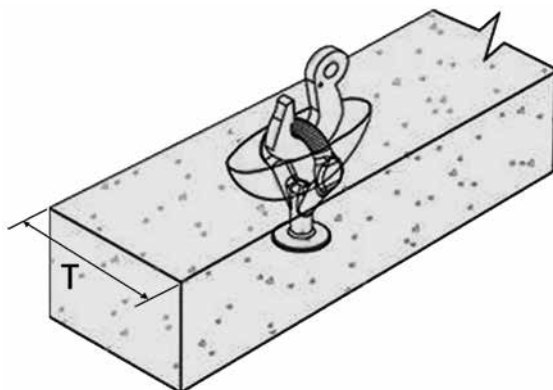

P75 and P75H Utility Anchor®

The Dayton Superior Utility Anchors are available in three diameters and a series of lengths for specific concrete thickness. The utility anchor can be set in either a 90° or a 45° anchor orientation using the appropriate setting plug.

To Order:

Specify: (1) quantity, (2) name, (3) product code.

Example:

200, P75 Utility Anchors, 5UA444.

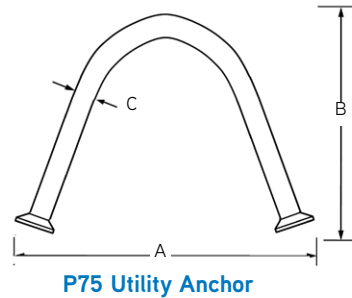

P75 Utility Anchor

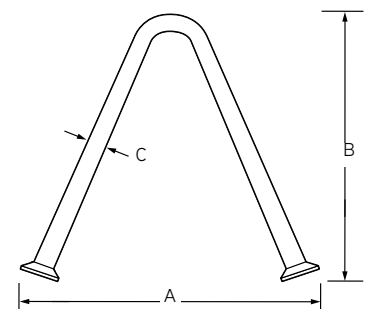

P75H Utility Anchor

Anchor	Type	Product Code	Minimum Panel Thickness	Safe Working Load Tension 90	Safe Working Load Shear 90	Safe Working Load Tension/Shear 45	Minimum Edge Distance	A	B	C	End Shape
P75	4UA444	121877	4"	3,200	5,800	2,260	9"	5-1/4"	3-1/8"	0.444"	Swift Lift
	5UA444	123442	5"	3,860	7,710	2,730	10"	6"	3-3/4"		
	6UA444	121888	5-5/8"	4,460	9,460	3,150	12"	7-3/8"	4-3/4"		
	5UA671	123441	5"	4,560	8,430	3,220	10"	6-7/16"	3-3/4"	0.671"	
	6UA671	121889	5-5/8"	7,320	15,780	5,170	12"	7-3/8"	4-3/4"		
	8UA671	121891	7-5/8"	10,830	18,850	7,660	16"	9-3/4"	6-3/4"		
P75H	12UA875	124738	12"	24,000	24,000	24,000	30"	15-7/8"	11"	0.875"	

Note:

- Compressive strength of normal weight concrete to be 4,000 psi at time of initial lift.
- Safe working loads provide an approximate factor of safety of 4 to 1.
- Utility anchors to be installed at 90° to surface of the concrete.
- Shear safe working loads are based on loading in the direction of the top of the precast concrete element.

P75C Utility Anchor® with Clip

The Dayton Superior Utility Anchor with Clip is designed to allow the Utility Anchor to be secured to the wire mesh cage. This product utilizes the P75 Utility Anchors with 2 wire clips welded to opposite legs of the anchor. These wire clips are positioned to hold the utility anchor with Void to the wire mesh in the proper position in the wall for lifting your precast product. Both the 5UA and 6UA anchors in 0.444 and 0.671 diameters for 9" wire spacing are in stock. Other anchor and wire spacing are readily available.

To Order:

Specify: (1) quantity, (2) name, (3) product code (4) anchor size, (5) wire spacing (6) wall thickness.

Example:

200, P75C, #121443, 5UA444 anchor, 9" wire spacing, 5" wall.

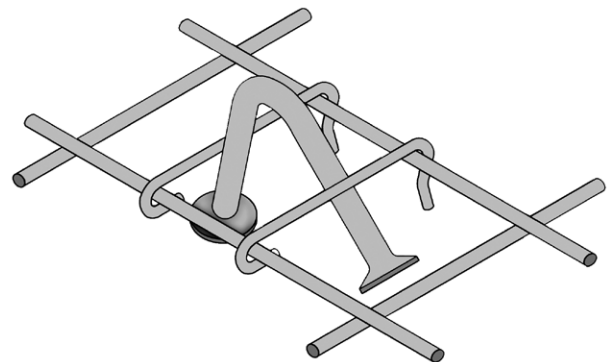

Product Code	Utility Anchor	Wire Clip Lengths	Wall Thickness
123443	5UA444	9"	5"
121890	5UA671	9"	5"
121892	6UA444	9"	6"
121893	6UA671	9"	6"
127446	8UA671	9"	8"

P76 Utility Anchor® Setting Plugs

Utility Anchor Setting Plugs are a polyurethane plastic in 90° and 45° orientation.

The reusable setting plug properly sets the anchor approximately 1/2" below the surface of the concrete and provides an adequate recess for easy sling attachment. After final positioning of the concrete element, the recess formed by the recess member can be easily grouted or conveniently covered by the Utility Anchor Cover/Patch.

The 90P875 Setting Plug used with the P75H 24,000 lb. anchor requires 2 each P101 holding rods to attach setting plug to the form. No holding plate or magnetic plate are available for this setting plug.

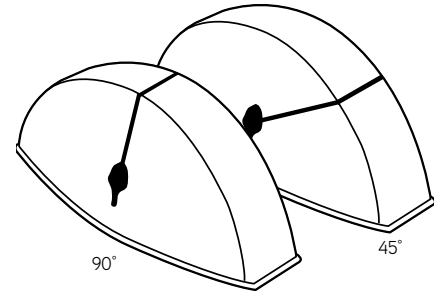

P76 Utility Anchor Setting Plugs

P76 Utility Anchor Setting Plug

Type	Product Code No.	Length	Width	Depth	Color
90P444	123175	8.00"	3.25"	3"	Blue
45P444	123176	8.00"	3.25"	3"	Blue
90P671	123177	8.00"	3.25"	3"	Orange
90P671	127786	9.00"	4.58"	3.35"	Orange
45P671	123178	8.00"	3.25"	3"	Orange
90P875	124685	15.00"	6.13"	5"	Blue

To Order:

Specify: (1) quantity, (2) name, (3) product code.

Example:

200, P76 Utility Anchor Setting Plugs, 90P444.

P76D Disposable Setting Plugs

The Disposable Setting Plug is manufactured to offer the precastor an inexpensive alternate to urethane setting plugs. This 2 piece high density polyethylene plastic setting plug is used with the 0.671 Dayton Superior Utility Anchors. The two piece design snaps tightly together around the legs of the anchor eliminating concrete entering the void. The setting plug is installed to the formwork using nail holes on each end of the plug.

To Order:

Specify: (1) quantity, (2) name, (3) product code.

Example:

200, P76D, #126214.

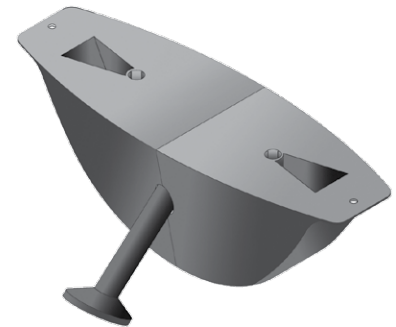

P76D Disposable Utility Anchor Setting Plugs 0.671

P76C Utility Anchor Cover/Patch

The P76C Utility Anchor Cover/Patch installs over the back of the setting plug to protect the unit without the use of duct tape. The cover/patch can be installed on the setting plug/anchor assembly prior to setting the assembly in the form. This protects the assembly from concrete leakage through the concrete placement sequence. It can also be used later as a temporary or permanent cover for the recess. The P76C cover is gray in color and will blend with most concrete. It can be painted to match other color schemes.

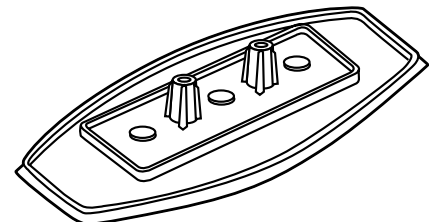

P76C Utility Anchor Cover/Patch

P76M Utility Anchor® Magnetic Setting Plate

The Dayton Superior P76M Utility Anchor Magnetic Setting Plates are available for easy setting of utility anchors in steel precast forms.

Use 3/8" P101 Holding Rod in threaded through hole to strip magnet from steel form.

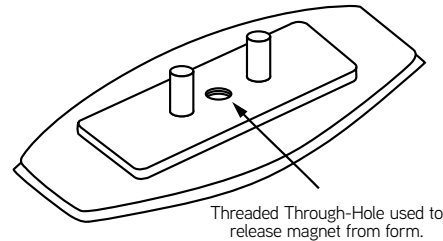

Threaded Through-Hole used to release magnet from form.

P76M Utility Anchor Magnetic Setting Plate

To Order:

Specify: (1) quantity, (2) name.

Example:

200, P76M Utility Anchor Magnetic Setting Plates.

P100 Utility Anchor® Holding Plate P101 Utility Anchor® Holding Rod

The Dayton Superior P100 Utility Anchor Holding Plate and P101 Holding Rod are used in various applications to install Utility Anchors in the form. The Holding Plate can be nailed, screwed, welded or double-face taped to the form. The setting plug/anchor assembly is pushed onto the projecting studs of the plate and held firmly in place through the concrete placement.

The Holding Rod is placed through a predrilled hole in the form and into the threaded insert in the setting plug. After fully seating the holding rod in the setting plug, the setting plug can be pulled up tightly to the form with the holding rod's free-running wing nut.

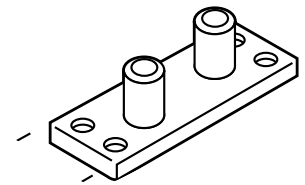

P100 Utility Anchor Holding Plate (FL111)

To Order:

Specify: (1) quantity, (2) name, (3) anchor diameter.

Example:

200, P100 Utility Anchor Holding Plates, 0.671 anchor diameter.

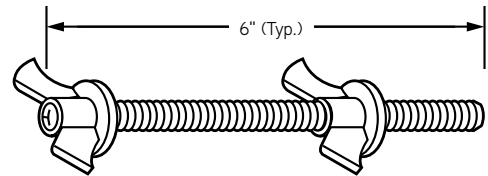

P101 Utility Anchor Holding Rod (3/8" Coil Thread) (FL131)

P104U One Piece Magnetic Utility Anchor® Recess

The Dayton Superior P104U One Piece Magnetic Utility Anchor Recess allows installation of Utility Anchors in a metal face form using a one piece rubber recess with Magnet imbedded in the top of the recess. Available for 0.444 or 0.671 Utility Anchors.

To Order:

Specify: (1) quantity, (2) name.

Example:

200, P104 One Piece Magnetic Utility Anchor Recess.



Utility Anchor Lifting System

Anchor Placement

Placement of the Utility Anchor is dependent on the structural shape of the precast unit and/or the manufacturer's preference. The Utility Anchors are not designed for thin edge installations. Always maintain minimum edge distances and adjust anchor capacities if concrete strengths, other than those noted in the capacity chart, are encountered. Refer to edge distance chart.

In-Form setting:

1. Assemble setting plug and anchor.
2. Affix holding plate (nail, weld, magnetic setting plate, double-face tape) to the form.
3. Push the setting plug/anchor assembly onto the holding plate and firmly against the form.

Through-Form Setting

1. Assemble setting plug and anchor.
2. Insert holding rod through form and line up setting plug.
3. Finger-tighten holding rod and lock assembly in place with the running wing nut.

Wet Setting

1. Assemble setting plug holding plate and anchor.
2. Use cover/patch or duct tape to seal setting plug cavities.
3. Work the assembly down into the wet concrete until the top surface of the plug is flush with the surface of the concrete.

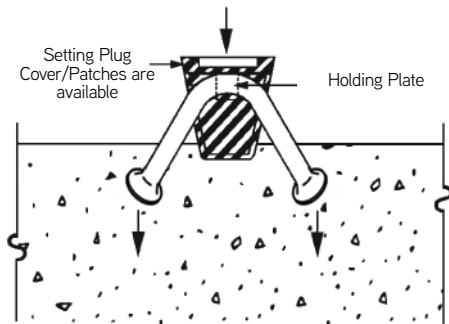

"Wet" Setting

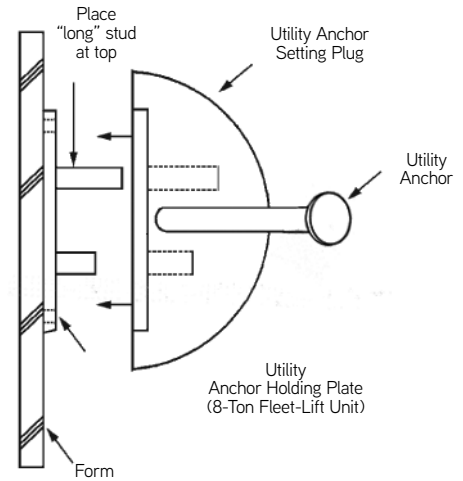

In-Form Setting

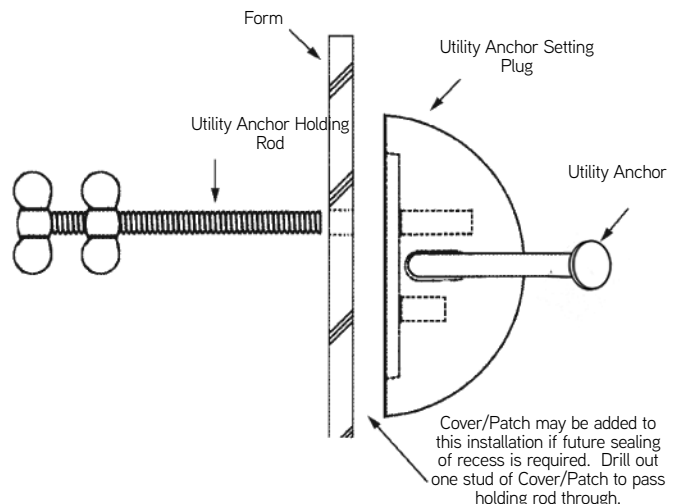

Through-Form Setting

Utility Anchor Lifting System

P76 Utility Anchor® and Double Tee Anchor Setting Plug

The new P76 Setting Plug is a re-usable polyurethane setting plug designed to provide a larger recess in the concrete for the 0.671 Utility Anchors and the Double Tee Anchors. This setting plug is 9.0" in length, 4.5" in width across the top, and 3.3" in depth. This recess member positions the anchor at a 90 degree angle to the surface of the concrete product. The reusable setting plug sets the anchor approximately 1/2" below the top of the concrete. The setting plug is attached to the form with the P101 Holding Rod and/or the P100 Holding Plate. The P76 Setting Plug is stripped from the concrete by placing two 3/8" dia. rods into the holes provided in the plug and using a 'scissor action' to strip the plug from the anchor.



To Order:

Specify: (1) quantity, (2) name, (3) product code.

Example:

200, P76 Utility Anchor and Double Tee Anchor Setting Plug, #127786.

P110 Wire Rope Lifting System™

The Wire Rope Lifting System is an economical lifting loop for utility type structures. It is used in face lift applications and is 'mucked' into the surface of the concrete. The galvanized wire rope is formed in a figure 8 shape, with the ends of the rope secured by a positive swaged clamp, and a steel band at approximately the mid point to establish the proper shape. The Wire Rope Lifting System is embedded 2/3 of its length into the concrete. The hardware must be standard hook or clevis with a diameter at least twice the rope diameter. Each anchor has a color-coded tag which identifies the SWL in tension of the anchor.



Product Features and Benefits:

- 7 standard sizes – handles most precast applications up to 10,000 lb SWL
- Mucked into surface – no recess members required by the precaster
- Uses standard jobsite Crosby Hooks – no hardware purchases required by precaster.
- Galvanized wire rope – reduces rusting of the anchor
- Can be cut off or left exposed – reduces labor cost for precaster
- Economical – for the cost conscious precaster

To Order:

Specify: (1) quantity, (2) name, (3) product code.

Example:

200, P110 Wire Rope Lifting System #127327.

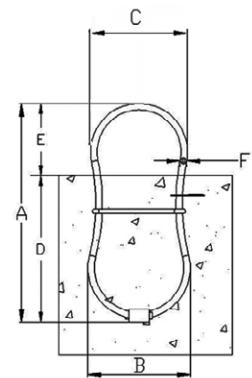

Part #	Description	Safe Working Load	A	B	C	D	E	F
#127326	0.8 T	1,600#	8.07"	3.7"	3.3"	5.7	2	0.24
#127327	1.2 T	2,400#	9.06"	3.9"	3.5"	6.6	2.50	0.275
#127328	1.6 T	3,200#	9.84"	5.1"	4.9"	7.1	2.75	0.313
#127329	2.0 T	4,000#	11.81"	5.3"	4.9"	8.7	3.13	0.375
#127330	2.5 T	5,000#	12.80"	5.5"	4.9"	9.4	3.38	0.375
#127331	3.8 T	7,600#	14.57"	6.5"	5.7"	10.7	3.88	0.473
#127332	5.0 T	10,000#	14.96"	7.6"	5.7"	11.1	3.80	0.630

NOTE: SWL is 4:1 SF in 3000 psi concrete

Tag Color: White= 0.8T, Red= 1.2T, Pink= 1.6T, Light Green= 2.0T, Dark Green= 2.5T, Emerald Green= 3.8T, Light Yellow= 5.0T

Wire Loop Parallel To Wall Thickness

Anchor Tonnage	Minimum Wall Thickness	Overall Length	Embedment Depth	Minimum Edge Distance	Minimum Corner Distance	SWL @ 3000 psi	Concrete Strength For maximum SWL	Maximum SWL
0.8 ton	4.0"	8.0625"	5.7"	2.0"	8.75"	1,600lbs	3,000 psi	1,600 lbs.
1.2 ton	4.5"	9.375"	6.5"	2.25"	9.75"	2,400lbs	3,000 psi	2,400 lbs
1.6 ton	4.75"	9.8125"	7"	2.375"	10.5"	2,841lbs	4,000 psi	3,200 lbs
2.0 ton	6"	11.8125"	8.7"	3"	13.25"	3,547lbs	4,000 psi	4,000 lbs
2.5 ton	7.0"	12.34"	9.4"	3.5"	14.25"	4,898lbs	3,500 psi	5,000 lbs
3.8 ton	9.0"	14.5"	10.7"	4.5"	16.25"	6,796 lbs	4,000 psi	7,600 lbs
5.0 ton	12"	14.9375"	11.1"	6"	16.75"	9,539 lbs	3,500 psi	10,000 lbs

Wire Loop Perpendicular To Wall Thickness

Anchor Tonnage	Minimum Wall Thickness	Overall Length	Embedment Depth	Minimum Edge Distance	Minimum Corner Distance	SWL @ 3000 psi	Concrete Strength For maximum SWL	Maximum SWL
0.8 ton	5.5"	8.0625"	5.7"	2.75"	8.75"	1,600lbs	3,000 psi	1,600 lbs.
1.2 ton	6"	9.375"	6.5"	3"	9.75"	2,400lbs	3,000 psi	2,400 lbs
1.6 ton	6.5"	9.8125"	7"	3.25"	10.5"	2,700lbs	4,500 psi	3,200 lbs
2.0 ton	7"	11.8125"	8.7"	3.5"	13.25"	3,474 lbs	4,000 psi	4,000 lbs
2.5 ton	7.5"	12.34"	9.4"	3.75"	14.25"	4,251 lbs	4,500 psi	5,000 lbs
3.8 ton	9.0"	14.5"	10.7"	4.5"	16.25"	5,468 lbs	6,000 psi	7,600 lbs
5.0 ton	12"	14.9375"	11.1"	6"	16.75"	7,739 lbs	5,000 psi	10,000 lbs

B1 or B2 Coil Ties Used as Inserts

The Dayton Superior B1 Two Strut Coil Tie and B2 Four Strut Coil Tie, when used as inserts for lifting and handling thin wall precast elements, are extremely effective.

Coil ties are available with an optional B3 Screw-on Coil for use with the B30 Screw-on Plastic Cone to set the insert back from the face of the concrete.

Minimum spacing between inserts is twice the corner distance.

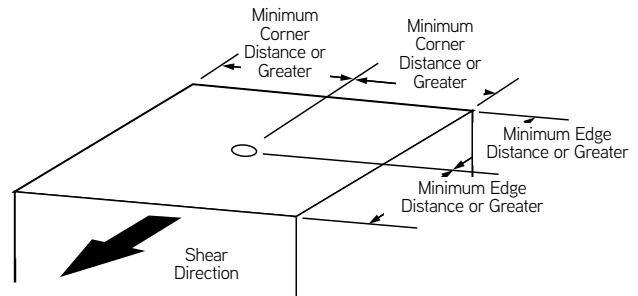

B1 or B2 Coil Ties

Insert Type	Bolt Diameter	Insert Height	Minimum Edge Distance	Minimum Corner Distance	Safe Working Load Tension	Safe Working Load Shear	A	B	C
B1	3/4"	6"	8"	14"	4,500 lbs	2,810 lbs	6"	1-5/8"	0.375"
B1	3/4"	6"	14"	21"	4,500 lbs	4,500 lbs	6"	1-5/8"	0.375"
B1	1"	6"	8"	14"	5,447 lbs	3,200 lbs	6"	2-1/4"	0.440"
B1	1"	6"	16"	24"	6,120 lbs	6,120 lbs	6"	2-1/4"	0.440"
B1	1-1/4"	8"	10"	15"	6,750 lbs	4,670 lbs	8"	2-1/2"	0.440"
B1	1-1/4"	8"	16"	24"	6,750 lbs	6,750 lbs	8"	2-1/2"	0.440"
B2	3/4"	6"	8"	14"	5,536 lbs	4,710 lbs	6"	1-5/8"	0.375"
B2	3/4"	6"	12"	16"	6,220 lbs	6,220 lbs	6"	1-5/8"	0.375"
B2	1"	8"	10"	15"	7,897 lbs	5,640 lbs	8"	2"	0.375"
B2	1"	8"	16"	24"	9,000 lbs	9,000 lbs	8"	2"	0.375"
B2	1"	12"	10"	15"	9,000 lbs	6,100 lbs	12"	2"	0.375"
B2	1"	12"	15"	22"	9,000 lbs	9,000 lbs	12"	2"	0.375"
B2	1-1/4"	8"	12"	18"	9,400 lbs	7,840 lbs	8"	2-1/2"	0.440"
B2	1-1/4"	8"	15"	22"	9,400 lbs	9,390 lbs	8"	2-1/2"	0.440"
B2	1-1/4"	12"	15"	22"	13,500 lbs	10,500 lbs	12"	2-1/2"	0.440"
B2	1-1/4"	12"	20"	30"	13,500 lbs	13,500 lbs	12"	2-1/2"	0.440"

Safe Working Load provides a factor of safety of approximately 4 to 1 in 3,000 psi normal weight concrete.

Safe Working Loads are based on 1/2" setback from face of concrete.

NOTE: Contact Dayton Superior Technical Assistance for shear loads for inserts located near an edge smaller than in the table. B1 or B2 Coil Ties

Insert Type	Bolt Diameter	Insert Height	Safe Working Load Mechanical	Safe Working Load Tension Concrete *	A	B	C
B1	3/4"	6"	4,500 lbs	6,220 lbs	6"	1-5/8"	0.375"
B1	1"	6"	6,750 lbs	6,120 lbs	6"	2-1/4"	0.440"
B1	1-1/4"	8"	6,750 lbs	9,400 lbs	8"	2-1/2"	0.440"
B2	3/4"	6"	9,000 lbs	6,220 lbs	6"	1-5/8"	0.375"
B2	1"	8"	9,000 lbs	9,514 lbs	8"	2"	0.375"
B2	1"	12"	9,000 lbs	17,525 lbs	12"	2"	0.375"
B2	1-1/4"	8"	13,500 lbs	9,400 lbs	8"	2-1/2"	0.440"
B2	1-1/4"	12"	13,500 lbs	17,369 lbs	12"	2-1/2"	0.440"

NOTE: * SWL Tension Concrete values are provided for use with the tables on pages 17 and 18 for tension load reduction due to edge distance conditions closer than 1.5 x the insert length. Installed SWL is determined by the actual concrete capacity (edge conditions, strength, etc.), but can never be greater than the mechanical rating of the anchor.

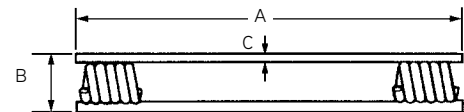

B1 Two Strut Coil Tie

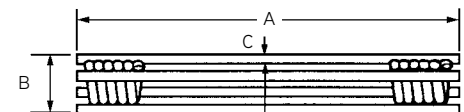

B2 Four Strut Coil Tie

To Order:

Specify: (1) quantity, (2) product code, (3) bolt diameter, (4) length, (5) finish.

Example:

400, B1 Coil Ties, 1-1/4" dia. x 8" long, plain finish.

Mounting Washers

Most Dayton Superior 1/2", 3/4", 1", 1-1/4" or 1-1/2" diameter coil inserts are available with an 11 gauge mounting washer welded to the upper ends of the strut wires. The 1/2", 3/4" and 1" diameter coil inserts use a 2" x 2" square washer, while the 1-1/4" and 1-1/2" inserts use a 3" x 3" square washer.

The mounting washer allows an insert to be fastened to wood forms with ease. When inserts are ordered with mounting washers, they are supplied with Ethafoam plugs to keep concrete out of the coil. Removal of the Ethafoam plug clears the insert, allowing for proper engagement of the lifting bolt.

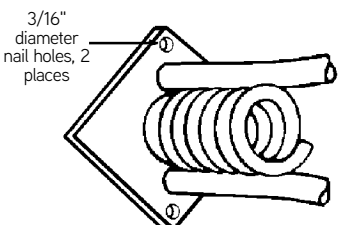

Mounting Washer

B11 Flat Washer

Made from carbon steel.

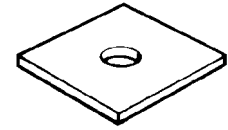

B11 Flat Washer

Type	Bolt Diameter	Safe Working Load	Sizes
B11 Standard	1/2"	1,800 lbs.	3" x 4" x 1/4"
B11 Heavy	1/2"	2,700 lbs.	4" x 5" x 1/4"
B11 Standard	3/4"	2,700 lbs.	4" x 5" x 3/8"
B11 Heavy	3/4"	3,600 lbs.	5" x 5" x 3/8"
B11 Standard	1"	7,200 lbs.	5" x 5" x 1/2"
B11 Heavy	1"	15,000 lbs.	7" x 7" x 3/4"
B11 Standard	1-1/4"	10,800 lbs.	5" x 5" x 5/8"
B11 Heavy	1-1/4"	15,000 lbs.	7" x 7" x 3/4"
B11 Standard	1-1/2"	15,000 lbs.	5" x 5" x 3/4"
B11 Heavy	1-1/2"	15,000 lbs.	7" x 7" x 3/4"

Safe Working Load provides a factor of safety of approximately 5 to 1.

To Order:

Specify: (1) quantity, (2) type, (3) diameter of bolt to be used, (4) finish.

Example:

200, B11 Heavy Flat Washers, 1" bolt dia., plain finish.

B12 Coil Rod

- Available high tensile B12 strengths.
- May be cut with carborundum blades without damaging the threads.
- Do not use cutting torch to cut coil rod to length.
- Used with B13 or B25 Coil Nuts for making special coil bolts.
- B12 requires two B13 or one B25 Coil Nut to develop safe working loads.
- B12 standard length is 12'-0" and P49 standard length is 10'-0".
- Available in any length up to 20'-0" on special order.



Coil Rod

To Order:

Specify: (1) quantity, (2) name, (3) diameter, (4) length.

Example:

200, B12 Coil Rod, 1" dia. x 12'-0" long.

B13 Coil Nut and B25 Heavy Coil Nut

Bolt Diameter	B12 Safe Working Load		P49 Safe Working Load	
	Tension	Shear	Tension	Shear
1/2"	3,600 lbs.	2,400 lbs.	2,700 lbs.	1,800 lbs.
3/4"	7,200 lbs.	4,800 lbs.	-	-
1"	15,000 lbs.	10,000 lbs.	-	-
1-1/4"	22,500 lbs.	15,000 lbs.	-	-
1-1/2"	27,000 lbs.	18,000 lbs.	-	-

Safe Working Load provides a factor of safety of approximately 5 to 1.



B13 Coil Nut

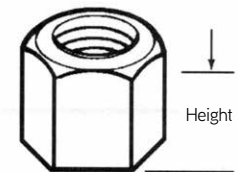

B25 Heavy Coil Nut

To Order:

Specify: (1) quantity, (2) name, (3) diameter.

Example:

200, B13 Coil Nuts, 1" diameter.

Type	Diameter	Approx. Height	Safe Working Load tension	
			Using one B13 Nut	Using two B13 Nuts or one B25 Heavy Nut
B13	1/2" Height	7/16"	2,400 lbs.	3,600 lbs.
B25	1/2"	1-3/16"	-	3,600 lbs.
B13	3/4"	5/8"	3,600 lbs.	7,200 lbs.
B25	3/4"	1-3/16"	-	7,200 lbs.
B13	1"	1"	9,600 lbs.	15,000 lbs.
B25	1"	2"	-	15,000 lbs.
B13	1-1/4"	1-1/4"	14,400 lbs.	22,500 lbs.
B13	1-1/2"	1-1/2"	19,000 lbs.	27,000 lbs.

Safe Working Load provides a factor of safety of approximately 5 to 1.

B14 Coil Bolt

B14 coil bolts are available in 1/2", 3/4", 1", 1-1/4" and 1-1/2" diameters with integrally formed heads.

Coil Bolts have fast-acting and self-cleaning threads. They can be reused, but will wear and must be regularly inspected for wear and damage. Keep bolts clean and lubricated at all times.

When determining the overall length of a coil bolt, you must consider:

- Height of hardware and/or formwork "grip"
- Insert Setback
- Minimum coil penetration
- The minimum coil penetration shown in the tables below, apply to all coil products

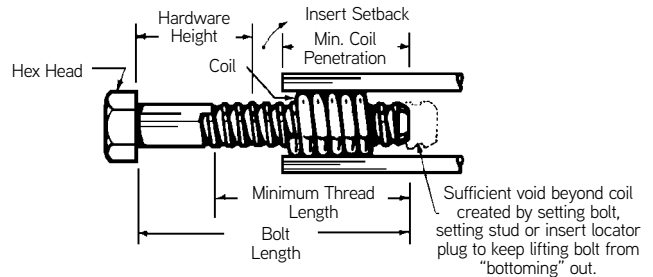

To Order:

Specify: (1) quantity, (2) type, (3) diameter, (4) length, (5) type.

Example:

200, B14 Coil Bolts, 1" dia. X 12" long, forged head.

B14 Coil Bolts with Integrally Formed Hex Heads

1/2" Diameter Forged Hex Head Safe Working Load		3/4" Diameter Forged Hex Head Safe Working Load		1" Diameter Forged Hex Head Safe Working Load		1-1/4" Diameter Forged Hex Head Safe Working Load		1-1/2" Diameter Forged Hex Head Safe Working Load	
Tension	Shear	Tension	Shear	Tension	Shear	Tension	Shear	Tension	Shear
3,600 lbs.	2,400 lbs.	8,000 lbs.	5,300 lbs.	14,500 lbs.	9,600 lbs.	20,300 lbs.	13,500 lbs.	29,500 lbs.	19,600 lbs.
Minimum Coil Penetration 2"		Minimum Coil Penetration 2-1/4"		Minimum Coil Penetration 2-1/2"		Minimum Coil Penetration 2-1/2"		Minimum Coil Penetration 3"	
Bolt Length	Minimum Thread Length	Bolt Length	Minimum Thread Length	Bolt Length	Minimum Thread Length	Bolt Length	Minimum Thread Length	Bolt Length	Minimum Thread Length
3"	2-1/4"	3"	2-3/4"	3"	2-3/4"	3"	2-3/4"	-	-
4"	3-1/4"	4"	3-3/4"	4"	3-3/4"	4"	3-3/4"	4"	3-3/4"
5"	4-1/4"	5"	4-3/4"	5"	4-3/4"	5"	4-3/4"	5"	4-3/4"
6"	5"	6"	5-3/4"	6"	5-3/4"	6"	5-3/4"	6"	5-3/4"
Over 6"	5"	Over 6"	5-3/4"	Over 6"	5-3/4"	Over 6"	5-3/4"	Over 6"	5-3/4"

Safe Working Load provides a factor of safety of approximately 5 to 1.

B16 Straight Coil Loop Insert

Although simple in design and fabrication, the B16 Straight Coil Loop Insert is highly efficient for lifting and handling precast concrete elements. Standard inserts are shown in the chart. Special inserts for use with larger diameter coil bolts, or with loops having longer lengths and of heavier wire can be furnished, if required, on special order.

B16 Straight Coil Loop Insert

Bolt Diameter	Insert Length	Minimum Edge Distance	Minimum Corner Distance	Safe Working Load Tension	Safe Working Load Shear	A	B
1/2"	3"	2"	5"	810 lbs.	200 lbs.	3"	0.223"
		3"	5"	1,310 lbs.	325 lbs.		
		5"	10"	1,950 lbs.	1,050 lbs.		
		10"	10"	1,950 lbs.	1,350 lbs.		
3/4"	4"	2"	5"	1,190 lbs.	200 lbs.	4"	0.306"
		3"	5"	1,910 lbs.	325 lbs.		
		5"	10"	1,950 lbs.	1,050 lbs.		
		8"	10"	1,950 lbs.	2,250 lbs.		
1/2" 3/4" or 1"	6"	2"	7"	1,420 lbs.	225 lbs.	6"	0.306"
		3"	7"	2,240 lbs.	425 lbs.		
		5"	7"	3,600 lbs.	775 lbs.		
		12"	12"	3,600 lbs.	3,600 lbs.		

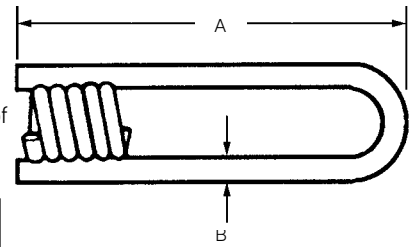

B16 Straight Coil Loop Insert

To Order:

Specify: (1) quantity, (2) name, (3) bolt diameter, (4) length, (5) finish.

Example:

200, B16 Straight Coil Loop Inserts, 1/2" dia. x 6" long, electro-plated finish

Safe Working Loads are based on 1/2" setback from face of concrete.
 Safe Working Load provides a factor of safety of approximately 4 to 1 in 3,000 psi normal weight concrete.
Note: Dayton Superior does not recommend the use of 1/2" diameter bolts for lifting/handling of precast panels.

Lifting/Handling Inserts and Accessories

B17 Double Flared Coil Loop Insert

The safe working load of the B17 Double Flared Coil Loop Insert is greatly increased over that of a B18 Single Flared Coil Loop. This increase in capacity is achieved by welding a second loop to the same coil. By adding the additional loop, it doubles the cross-sectional area of steel embedded in the concrete and at the same time, increases the area of the shear cone.

The design of the B17 insert leaves an open space between the two loops, allowing the B17 insert to "straddle" reinforcing steel or prestressing strands.

Standard sizes are shown in the table and other sizes are available on special order. Minimum spacing between inserts is twice the minimum corner distance.

B17 Double Flared Coil Loop Insert

Bolt Diameter	Minimum Edge Distance	Minimum Corner Distance	Safe Working Load Tension	Safe Working Load Shear	A	B	C	D
1" 1-1/4" or 1-1/2"	5"	15"	4,920 lbs.	2,760 lbs.	12"	0.375"	5-9/16"	5-9/16"
	9"	15"	9,500 lbs.	6,720 lbs.				
	12"	18"	9,500 lbs.	9,500 lbs.				
	18"	27"	9,500 lbs.	9,500 lbs.				
1" 1-1/4" or 1-1/2"	5"	15"	4,950 lbs.	2,940 lbs.	12"	0.440"	5-3/4"	5-3/4"
	9"	15"	9,810 lbs.	7,120 lbs.				
	12"	18"	11,150 lbs.	10,960 lbs.				
	18"	27"	13,500 lbs.	13,500 lbs.				

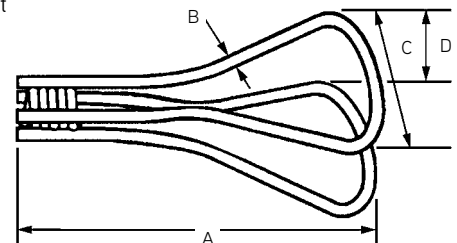

B17 Double Flared Coil Loop Insert

To Order:

Specify: (1) quantity, (2) name, (3) bolt diameter, (4) length, (5) finish.

Example:

400, B17 Double Flared Coil Loop Inserts, 1-1/4" dia. x 12-3/8" long, plain finish.

Safe Working Loads are based on 1/2" setback from face of concrete.
 Safe Working Load provides a factor of safety of approximately 4 to 1 in 3,000 psi normal weight concrete.

B18 Single Flared Coil Loop Insert

The load carrying capacity of any cast-in-place concrete insert is largely dependent upon the ability of the insert to draw upon the tensile strength of the mass of concrete within which it is embedded. The B18 Single Flared Coil Loop Insert makes effective use of this principle by increasing the depth and width of concrete embedment.

B18 inserts are available with an optional B3 Screw-on Coil for use with the B0 Screw-on Plastic Cone which acts to set the insert back from the face of the concrete.

Minimum spacing between inserts is twice the corner distance.

B18 Single Flared Coil Loop Insert

To Order:

Specify: (1) quantity, (2) name, (3) bolt diameter, (4) length, (5) finish.

Example:

200, B18 Single Flared Coil Loop Inserts,
1" dia. x 12" long, plain finish.

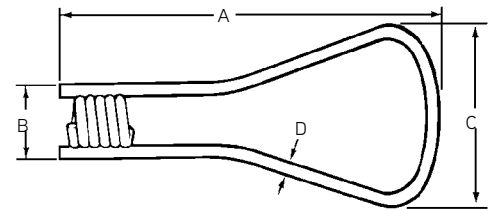

B18 Single Flared Coil Loop Insert

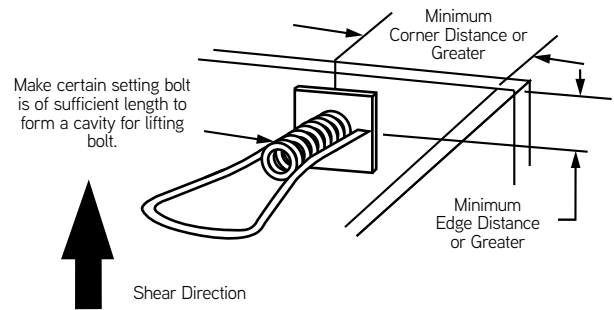

Bolt Diameter	Insert Height	Min. Edge Distance	Min. Corner Distance	Safe Working Load Tension	Safe Working Load Shear	A	B	C	D
1/2"	4"	5"	10"	2,250 lbs.	1,510 lbs.	4"	1-3/16"	3"	0.223"
	4"	8"	10"	2,250 lbs.	2,250 lbs.				
3/4"	6"	5"	10"	2,930 lbs.	1,770 lbs.	6"	1-5/8"	5-1/2"	0.306"
	6"	12"	12"	3,750 lbs.	3,750 lbs.				
3/4"	9"	5"	10"	3,750 lbs.	1,770 lbs.	9"	1-5/8"	5-1/2"	0.306"
	9"	12"	12"	3,750 lbs.	3,750 lbs.				
3/4"	12"	5"	10"	3,750 lbs.	1,770 lbs.	12"	1-5/8"	5-1/2"	0.306"
	12"	12"	12"	3,750 lbs.	3,750 lbs.				
3/4"	9"	5"	10"	4,500 lbs.	1,960 lbs.	9"	1-3/4"	5-5/8"	0.375"
	9"	15"	15"	4,500 lbs.	4,500 lbs.				
3/4"	12"	5"	10"	4,500 lbs.	1,960 lbs.	12"	1-3/4"	5-5/8"	0.375"
	12"	12"	12"	4,500 lbs.	4,500 lbs.				
1"	6"	5"	10"	2,920 lbs.	1,960 lbs.	6"	1-7/8"	5-5/8"	0.375"
	6"	12"	12"	4,500 lbs.	4,500 lbs.				
1"	9"	5"	10"	4,500 lbs.	1,960 lbs.	9"	1-7/8"	5-5/8"	0.375"
	9"	12"	12"	4,500 lbs.	4,500 lbs.				
1"	12"	5"	10"	4,500 lbs.	1,960 lbs.	12"	1-7/8"	5-5/8"	0.375"
	12"	12"	12"	4,500 lbs.	4,500 lbs.				
1"	12"	5"	12"	5,970 lbs.	2,130 lbs.	12"	2-1/4"	5-7/8"	0.440"
	12"	14"	14"	7,500 lbs.	7,500 lbs.				
1-1/4"	12"	7"	10"	7,500 lbs.	3,530 lbs.	12"	2-1/2"	5-7/8"	0.440"
	12"	7"	14"	7,500 lbs.	3,530 lbs.				
1-1/2"	12"	7"	10"	7,500 lbs.	3,530 lbs.	12"	2-3/4"	5-7/8"	0.440"
	12"	14"	14"	7,500 lbs.	7,500 lbs.				

Safe Working Loads are based on 1/2" setback from face of concrete.

Safe Working Load provides a factor of safety of approximately 4 to 1 in 3,000 psi concrete.

Note: Dayton Superior does not recommend the use of 1/2" diameter bolts for lifting/handling of precast panels.

B33 Double Flared Coil Loop Insert

The safe working load of the B33 Double Flared Coil Loop Insert is identical to the B17 Double Flared Coil Loop. However, its crisscross design will not allow the insert to “straddle” reinforcing steel or prestressing strands.

Standard sizes are shown in the table and other sizes are available on special order. Minimum spacing between inserts is twice the minimum corner distance.

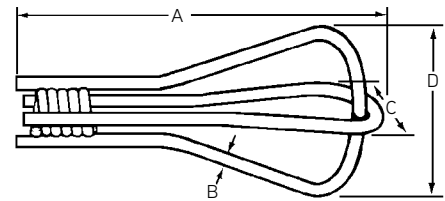

B33 Double Flared Coil Loop Insert

To Order:

Specify: (1) quantity, (2) name, (3) bolt diameter, (4) length, (5) finish.

Example:

400, B33 Double Flared Coil Loop Inserts, 1-1/4" dia. x 12-3/8" long, plain finish.

B33 Double Flared Coil Loop Insert Selection Table

Bolt Diameter	Minimum Edge Distance	Minimum Corner Distance	Safe Working Load Tension	Safe Working Load Shear	A	B	C	D
1" 1-1/4" or 1-1/2"	5"	15"	4,910 lbs.	2,760 lbs.	12-3/8"	0.375"	5-9/16"	5-9/16"
	9"	15"	9,500 lbs.	6,720 lbs.				
	12"	18"	9,500 lbs.	9,500 lbs.				
	18"	18"	9,500 lbs.	9,500 lbs.				
1" 1-1/4" or 1-1/2"	5"	15"	4,970 lbs.	2,940 lbs.	12-1/2"	0.440"	5-3/4"	5-3/4"
	9"	15"	9,650 lbs.	7,120 lbs.				
	12"	18"	10,960 lbs.	10,960 lbs.				
	22"	22"	13,500 lbs.	13,500 lbs.				

Safe Working Load provides a factor of safety of approximately 4 to 1 in 3,000 psi normal weight concrete. Safe Working Loads are based on 1/2" setback from face of concrete.

Lifting/Handling Inserts and Accessories

F47 Double Flared Loop Insert

The Dayton Superior F47 Double Flared Loop Insert has been designed for use in 3-1/4" or thicker precast concrete elements. This insert is available for use with 3/4" diameter coil bolts only.

To Order:

Specify: (1) quantity, (2) name, (3) finish.

Example:

200, F47 Double Flared Loop Inserts, plain finish.

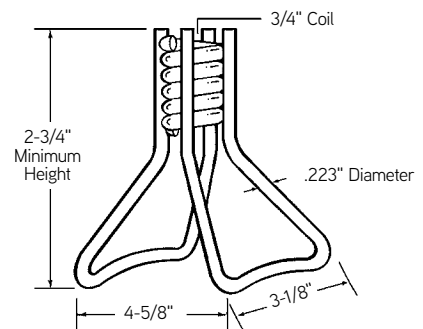

F47 Double Flared Loop Insert

Bolt Diameter x Insert Height	Safe Working Load Tension	Concrete Strength	Minimum Edge Distance
3/4" x 2-3/4"	2,750 lbs.	2,500 psi	6"

Safe Working Load provides a factor of safety of approximately 4 to 1 in normal weight concrete. Safe Working Loads are based on 1/2" setback from face of the concrete.

F48 Eye Nut, F49 Eye Bolt and F49A Eye Bolt

The Dayton Superior F48 Eye Nut is cast from ductile iron that meets ASTM Standard A-536 Grade 80-55-06. The eye nut is cast with coil threads and is intended to be used with B12 Coil Rod that has been cut to the proper length. The eye nut eliminates the need to inventory several different lengths of eye bolts.

To make permanent length eye bolts, it is possible to weld lengths of coil rod to the casting. Since improper welding techniques can result in reduced safe working loads, Dayton Superior recommends that you contact your local welding supply house for proper welding instructions and techniques.

The F49 Eye Bolt is an F48 Eye Nut supplied with a specified length of coil rod that has been welded in place. In order to develop the F49 eye bolt's rated load, the shoulder must be tightened securely against the face of the concrete.

The F48 Eye Nut and F49 Eye Bolt are intended for straight tensile loading only; pulling or lifting at an angle drastically reduces the safe working load and is not recommended.

F48 Eye Nut and F49 Eye Bolt Selection Table

Safe Working Load - Tension	Coil Rod Diameter	A	B	C	D	E
2,700 lbs.	1/2"	3-1/4"	1"	1"	3/4"	2"
3,600 lbs.	3/4"	3-1/2"	1"	1"	3/4"	2"
7,200 lbs.	1"	5"	1-1/4"	1-3/4"	1"	3"
10,800 lbs.	1-1/4"	6-1/4"	1-1/2"	2-1/4"	1-1/4"	4"

Safe Working Load provides a factor of safety of approximately 5 to 1.

Note: Dayton Superior does not recommend the use of 1/2" diameter bolts for lifting/handling of precast panels.

The F49A Eye Bolt is a forged, carbon steel, one piece, shoulder pattern eye bolt. It is available with 3/4" or 1" diameter coil threads and stocked in 3-1/2" and 6" lengths. Other lengths are available special order.

In order to develop the F49A Eye Bolt's rated load, the shoulder must be tightened firmly against the face of the concrete. The eye bolt is intended for straight tensile loading only; pulling or lifting at an angle drastically reduces the safe working load and is not recommended. The F49A Eye Bolt meets material requirements of ASTM Standard A-489.

To Order F48 Eye Nut:

Specify: (1) quantity, (2) name, (3) bolt diameter.

Example:

200, F48 Eye Nuts, 1" dia. bolt.

To Order F49 or F49A Eye Bolts:

Specify: (1) quantity, (2) name, (3) bolt diameter, (4) length.

Example:

200, F49 Eye Bolts, 1" dia. x 12" long.

Bolt Diameter	Tension Safe Working Load	A	B	C
3/4"	3,600 lbs.	2-7/8"	1-1/2"	3" or 6"
1"	6,400 lbs.	3-1/2"	1-3/4"	3"

Safe Working Load provides a factor of safety of approximately 5 to 1.

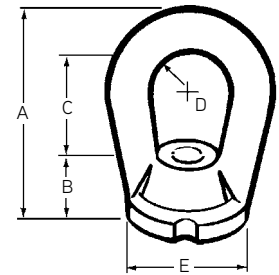

F48 Eye Nut

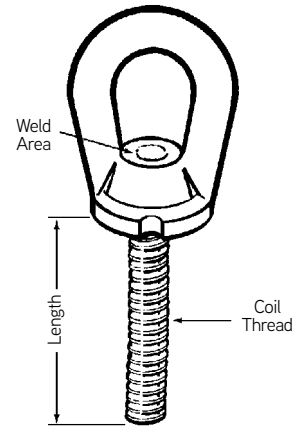

F49 Eye Bolt

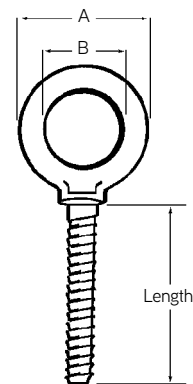

F49A Eye Bolt

P21 Wire Rope Loop

The P21 Dayton Superior Wire Rope Loop provides a fast method for handling precast items. Designed to work with 3/4" and 1" diameter coil inserts under straight tension loads only. Do not use under shear loading conditions, instead, use a swivel lift plate and coil bolt. With proper care, the wire rope loop can be reused. Visual evidence of any deterioration of the wire rope is a safety feature of this product.

Diameter x Type of Thread	Safe Working Load Tension	Loop Dimensions		
		A	B	C
1/2" Coil	2,000 lbs.	6"	2"	1-1/4"
3/4" Coil	5,200 lbs.	8-3/4"	2-1/2"	1-3/4"
1" Coil	8,000 lbs.	12"	3"	2-1/4"

Safe Working Load provides a factor of safety of approximately 5 to 1.

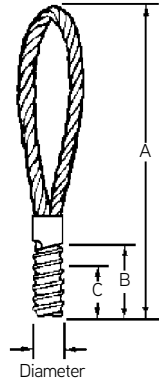

P21 Wire Rope Loop

To Order:

Specify: (1) quantity, (2) name, (3) diameter.

Example:

100, P21 Wire Rope Loop, 3/4" dia.coil.

F53 Thin Slab Coil Insert

The Dayton Superior F53 Thin Slab Coil Insert is designed for lifting thin precast concrete panels from the casting bed and for handling the panels until they are set into their final position. Inserts should be set back 1/2" from the surface of the concrete, maintaining at least 3/4" of concrete below the insert. Minimum spacing between inserts is twice the minimum corner distance. Available in insert heights up to 4".

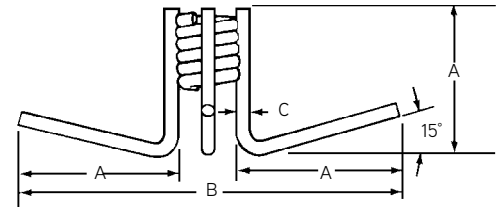

F53 Thin Slab Coil Insert

B33 Double Flared Coil Loop Insert Selection Table

Bolt Diameter	Minimum Edge Distance	Minimum Corner Distance	Safe Working Load Tension	Safe Working Load Shear	A	B	C
3/4"	3"	12"	2,340 lbs.	2,340 lbs.	3"	7-1/8"	0.306"
1"	4"	15"	3,520 lbs.	3,460 lbs.	4"	9-3/8"	
1-1/4"						9-5/8"	
1-1/2"						9-7/8"	

Safe Working Load provides a factor of safety of approximately 4 to 1 in 3,000 psi normal weight concrete. Safe Working Loads are based on 1/2" setback from face of concrete.

To Order:

Specify: (1) quantity, (2) name, (3) bolt diameter, (4) height, (5) finish.

Example:

200, F53 Thin Slab Coil Inserts, 1" dia. x 4" height, plain finish.

F56, F58 and F60 Expanded Coil Inserts

Expanded Coil Inserts are fabricated in two, four or six strut versions, as required. A standard coil is welded at one end of the strut wires and on the opposite end, an expanded pitch coil is welded. The expanded pitch coil welded to the more deeply embedded end of the insert, serves to distribute the applied loads over a larger volume of concrete.

- Ethafoam Plug installed when mounting washers are ordered.
- Minimum spacing between inserts is twice the minimum corner distance.
- Longer lengths available, if required.

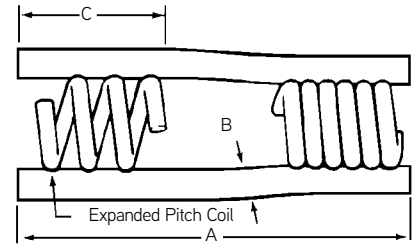

**F56 Expanded Coil Insert
for Coil Threaded Bolts**

**F56 Insert – 2 Struts
F58 Insert – 4 Struts
F60 Insert – 6 Struts**

Expanded Coil Insert Selection Table

Insert Type	Bolt Diameter	Insert Length	Min. Edge Distance	Min. Corner Distance	Safe Working Load Tension	Safe Working Load Shear	A	B	C
F56 Coil	3/4"	4-1/2"	2-1/2"	6"	1,800 lbs.	680 lbs.	4-1/2"	0.375"	1-1/2"
			4"	8"	2,220 lbs.	1,380 lbs.			
			8"	12"	4,250 lbs.	2,760 lbs.			
			14"	20"	4,250 lbs.	4,250 lbs.			
F56 Coil	1"	5-1/2"	2-1/2"	7"	2,000 lbs.	740 lbs.	5-1/2"	0.440"	2-1/2"
			4"	9"	2,560 lbs.	1,500 lbs.			
			8"	12"	5,300 lbs.	3,250 lbs.			
			18"	24"	6,250 lbs.	6,250 lbs.			
F58 Coil	1-1/4"	7-1/2"	3"	10"	2,480 lbs.	1,270 lbs.	7-1/2"	0.440"	2-3/4"
			5"	12"	3,600 lbs.	2,730 lbs.			
			8"	15"	5,700 lbs.	4,790 lbs.			
			18"	26"	10,480 lbs.	10,590 lbs.			
F60 Coil	1-1/2"	9-1/2"	3"	12"	2,820 lbs.	1,500 lbs.	9-1/2"	0.440"	3-5/8"
			5"	15"	3,880 lbs.	3,230 lbs.			
			8"	15"	6,680 lbs.	6,260 lbs.			
			22"	30"	14,580 lbs.	16,430 lbs.			

Safe Working Load provides a factor of safety of approximately 4 to 1 in 3,000 psi normal weight concrete.
Safe Working Load is based on a 1/2" setback from face of concrete.

To Order:

Specify: (1) quantity, (2) name, (3) bolt diameter, (4) finish.

Example:

200, F60 Expanded Coil Inserts, 1-1/2" diameter, plain finish.

F63 Flared Thin Slab Coil Insert

The Dayton Superior F63 Flared Thin Slab Coil Insert is designed for use in very thin slabs or other conditions where a longer insert cannot be used. Inserts should be set back 1/2" from the surface of the concrete, maintaining at least 3/4" of concrete below the insert. Minimum spacing between inserts is twice the minimum corner distance.

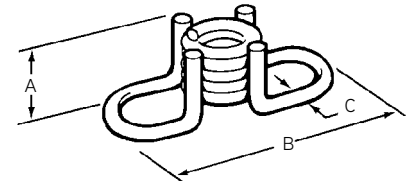

F63 Flared Thin Slab Coil Insert

To Order:

Specify: (1) quantity, (2) name, (3) bolt diameter, (4) height, (5) finish.

Example:

200, F63 Flared Thin Slab Coil Inserts, 1" dia. x 4-1/2", plain finish.

F63 Flared Thin Slab Coil Insert Selection Table

Bolt Diameter	Insert Length	Minimum Edge Distance	Minimum Corner Distance	Safe Working Load Tension	Safe Working Load Shear	A	B	C
1/2"	1-3/4"	6"	6"	1,520 lbs.	1,090 lbs.	1-3/4"	4-1/8"	0.223"
3/4"	2-5/16"	8"	8"	2,170 lbs.	1,640 lbs.	2-5/16"	4-7/8"	0.306"
3/4"	3-1/2"	9"	9"	3,570 lbs.	2,600 lbs.	3-1/2"	4-7/8"	0.306"
1"	2-5/16"	8"	8"	2,460 lbs.	1,970 lbs.	2-5/16"	5-1/4"	0.306"
1"	4-1/2"	12"	12"	5,280 lbs.	4,000 lbs.	4-1/2"	5-1/4"	0.306"

Safe Working Load provides a factor of safety of approximately 4 to 1 in 3,000 psi normal weight concrete.

Note: Dayton Superior does not recommend the use of 1/2" diameter bolts for lifting/handling of precast panels.

Lifting/Handling Inserts and Accessories

F65 Type L Coil Insert

The Dayton Superior F65 Type L Coil Insert is designed for use in lifting and handling lightweight precast concrete elements. Inserts should be set back 1/2" from the surface of the concrete. Minimum spacing between inserts is twice the minimum corner distance.

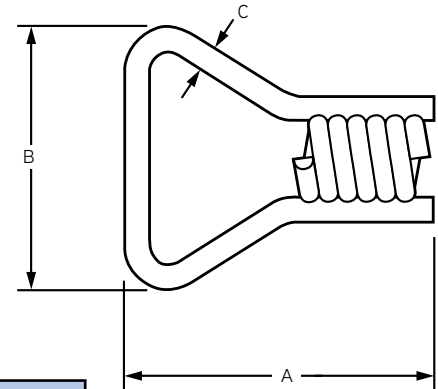

F65 Type L Coil Insert

To Order:

Specify: (1) quantity, (2) name, (3) bolt diameter, (4) finish.

Example:

200, F65, Type L Coil Inserts, 1/2" diameter, plain finish.

B16 Straight Coil Loop Insert

Bolt Diameter	Insert Length	Minimum Edge Distance	Minimum Corner Distance	Safe Working Load Tension	Safe Working Load Shear	A	B	C
1/2"	4"	2-1/2"	10"	1,150 lbs.	530 lbs.	4"	2-3/8"	0.223"
		5"	10"	2,250 lbs.	1,230 lbs.			
		8"	12"	2,250 lbs.	1,980 lbs.			
3/4"	4"	2-1/2"	10"	1,140 lbs.	600 lbs.	4"	3-3/8"	0.306"
		5"	10"	2,630 lbs.	1,400 lbs.			
		8"	12"	3,520 lbs.	2,250 lbs.			

Safe Working Load provides a factor of safety of approximately 4 to 1 in 3,000 psi normal weight concrete.

Note: Dayton Superior does not recommend the use of 1/2" diameter bolts for lifting/handling of precast panels.

Note: Table based on Face Lift usage of inserts.

T1 Single Pickup Insert

Dayton Superior T1 Single Pickup Inserts are available with plastic or stainless steel tips and with or without T21 Insert Locator Plugs installed. T1 inserts are designed for use with T12 or T26 Swivel Lifting Plates. Do not use T1 inserts as an edge or end pick-up insert.

Height of insert is 3/8" less than the panel's structural thickness. Standard panel thickness is shown in the chart and other panel thickness is available on special order.

Minimum spacing between inserts is twice the minimum corner distance.

T1 Single Pickup Insert Selection Table

Bolt Diameter	Panel Thickness	Safe Working Load Tension	Safe Working Load Shear
3/4"	4"	2,269 lbs.	4,539 lbs.
	5"	3,442 lbs.	5,400 lbs.
	6"	4,766 lbs.	5,400 lbs.
	7"	6,227 lbs.	5,400 lbs.
	8"	7,813 lbs.	5,400 lbs.
1"	4"	2,269 lbs.	4,539 lbs.
	5"	3,442 lbs.	5,520 lbs.
	6"	4,766 lbs.	5,520 lbs.
	7"	6,227 lbs.	5,520 lbs.
1-1/4"	4"	2,269 lbs.	4,539 lbs.
	5"	3,442 lbs.	5,520 lbs.
	6"	4,766 lbs.	5,520 lbs.
	7"	6,227 lbs.	5,520 lbs.
	8"	7,813 lbs.	5,520 lbs.
1-1/2"	4"	2,269 lbs.	4,539 lbs.
	5"	3,442 lbs.	5,520 lbs.
	6"	4,766 lbs.	5,520 lbs.
	7"	6,227 lbs.	5,520 lbs.
	8"	7,813 lbs.	5,520 lbs.

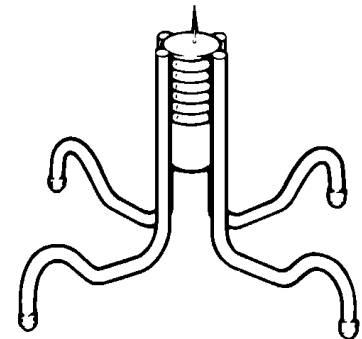

T1 Single Pickup Insert

To Order:

Specify: (1) quantity, (2) name, (3) diameter, (4) panel structural thickness, (5) type of tips.

Example:

200, T1 Single Pickup Inserts, 3/4" dia., 5" panel structural thickness, plastic tipped feet.

Safe Working Load provides a factor of safety of approximately 4 to 1 in 3,000psi normal weight concrete.

P1 Single Pickup Insert

Dayton Superior P1 Single Pickup Inserts are available with electro galvanized finish, with or without plastic dipped feet. Also available in stainless steel wire with or without plastic dipped feet. Installed T21 Insert Locator. Plugs are optional. P1 inserts are designed for use with T26 Swivel Lifting Plates. Do not use P1 inserts as an edge or end pickup insert.

- Standard insert heights are shown in the chart and other insert heights are available on special order
- Minimum spacing between inserts is twice the minimum corner distance
- Wire diameter = 0.440"

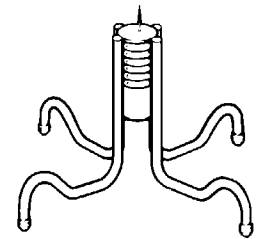

P1 Single Pickup Insert

P1 1-1/4" Diameter Insert Height	Insert Setback									
	1"		1-1/2"		2"		2-1/2"		3"	
	Tension	Shear	Tension	Shear	Tension	Shear	Tension	Shear	Tension	Shear
6"	7,454 lbs.	4,554 lbs.	8,276 lbs.	4,770 lbs.	9,126 lbs.	4,981 lbs.	10,004 lbs.	5,189 lbs.	10,909 lbs.	5,393 lbs.
7"	9,126 lbs.	4,981 lbs.	10,004 lbs.	5,189 lbs.	10,909 lbs.	5,393 lbs.	10,909 lbs.	5,593 lbs.	10,909 lbs.	5,791 lbs.
8"	10,909 lbs.	5,393 lbs.	10,909 lbs.	5,593 lbs.	10,909 lbs.	5,791 lbs.	10,909 lbs.	5,985 lbs.	10,909 lbs.	6,177 lbs.

Safe Working Load provides a factor of safety of approximately 4 to 1 in 3,000psi normal weight concrete.

To Order:

Specify: (1) quantity, (2) name, (3) diameter, (4) insert height (5) type of tips, (6) finish.

Example:

200, P1 Single Pickup Inserts, 3/4" dia., 6" insert height, plastic tipped feet, galvanized.

T3 and T3A End Pickup Inserts

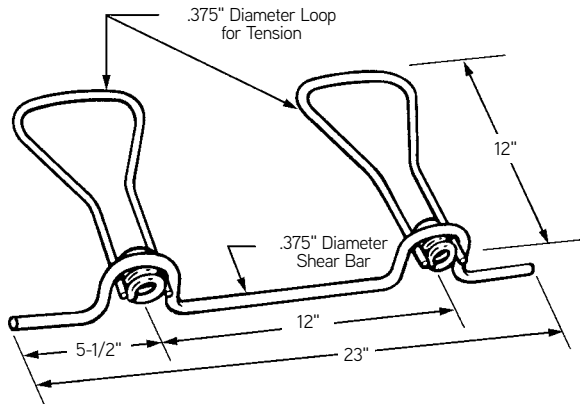

T3 End Pickup Insert

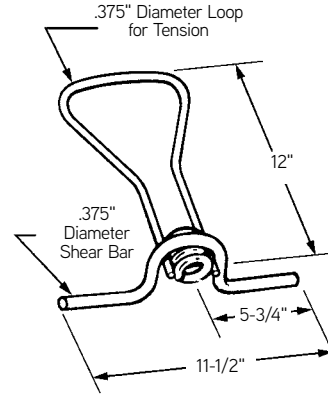

T3A End Pickup Insert

T3 and T3A End Pickup Insert Selection Table

Insert Type	Bolt Diameter	Load Condition	4" Panel	5" Panel	5-1/2" Panel	6" Panel	6-1/2" panel	7" Panel	7-1/2" Panel	8" Panel
T3A	3/4" Single	Tension	1,500 lbs.	—	—	—	—	—	—	—
		Shear	1,250 lbs.	—	—	—	—	—	—	—
	1" Single	Tension	—	3,000 lbs.	3,300 lbs.	3,600 lbs.	3,900 lbs.	4,200 lbs.	4,500 lbs.	4,500 lbs.
		Shear	—	1,350 lbs.	1,375 lbs.	1,400 lbs.	1,425 lbs.	1,450 lbs.	1,500 lbs.	1,550 lbs.
T3	3/4" Double	Tension	2,500 lbs.	—	—	—	—	—	—	—
		Shear	1,500 lbs.	—	—	—	—	—	—	—
	1" Double	Tension	—	4,000 lbs.	4,400 lbs.	4,800 lbs.	5,200 lbs.	5,600 lbs.	6,000 lbs.	6,000 lbs.
		Shear	—	2,100 lbs.	2,250 lbs.	2,400 lbs.	2,550 lbs.	2,700 lbs.	2,850 lbs.	3,000 lbs.

Safe working load provides a factor of safety of approximately 4 to 1 in 3,000 psi normal weight concrete.
 Safe Working Loads are based on 1/2" setback from face of concrete.

To Order:

Specify: (1) quantity, (2) name, (3) diameter.

Example:

200, T3 End Pickup Inserts, 1" diameter.

Lifting/Handling Inserts and Accessories

T7S and T7ST Slotted Setting Studs

The Dayton Superior T7S Slotted Setting Stud has a slot to facilitate installation and removal. The T7ST stud has a slot and is drilled 1" deep and tapped with 1/4"-20 threads to allow the stud to be used as an insert setting plug.

- Used with standard coil threaded inserts to provide void for B14 coil bolts.
- Made from continuous threaded steel rod.
- Top is cut off square so screed can pass over.
- Threads and slot should be coated with non-staining lubricant to prevent bonding.
- Loosen studs within 2 to 12 hours after concrete placement to ease removal when ready to lift.
- Standard steel sizes are 1/2", 3/4", 1", 1-1/4" and 1-1/2" diameter x 4" long. Other lengths available on request.

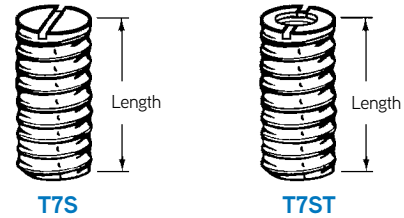

To Order:

Specify: (1) quantity, (2) name, (3) diameter.

Example:

200, T7S Slotted Setting Studs, 1" diameter.

P25 Plastic Setting Bolt

The Dayton Superior Plastic Setting Bolt is used to attach 1/2", 3/4" and 1" diameter coil inserts to wood frames. The head of the setting bolt has nail holes allowing easy attachment of the bolt. The plastic setting bolt positions the insert 3/4" from concrete surface.

Product Code	Bolt Diameter	Length Thread
100210	1/2"	2"
100220	3/4"	3-1/4"
100230	1"	4-3/4"

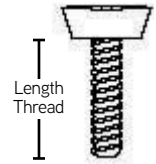

To Order:

Specify: (1) quantity, (2) name, (3) diameter.

Example:

200, P25 Plastic Setting Bolt, 1" diameter.

T8 Lifting Angle

- Designed for use with T2 Double Pickup Inserts.
- May be used for face lifting inserts and edge lifting inserts when panel thickness exceeds 6".
- Cut washers are required under head of all bolts.
- Made from structural steel angle in the sizes shown below.
- Safe Working Load is 18,000 lbs.

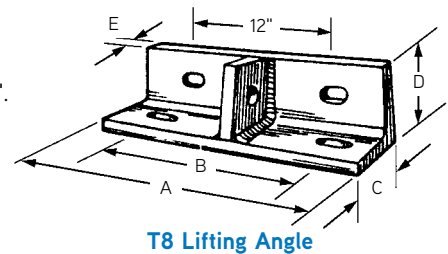

Bolt Diameter	A	B	C	D	E	Clevis Hole
1"	18"	12"	6"	4"	5/8"	1-3/4" dia.
1-1/4"	21"	15"	6"	6"	3/4"	1-1/2" dia.
1-1/2"						

To Order:

Specify: (1) quantity, (2) name, (3) bolt diameter.

Example:

200, T8 Lifting Angles, 1-1/4" bolt diameter.

T10 and T11 End Pickup Inserts

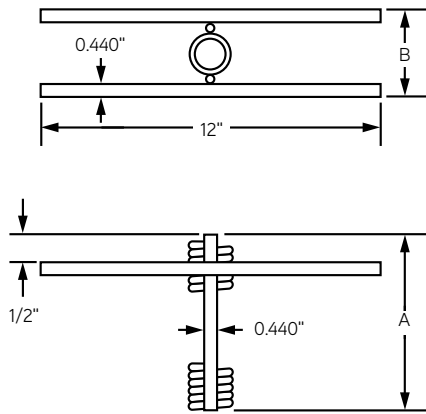

T10 Single End Pickup Insert

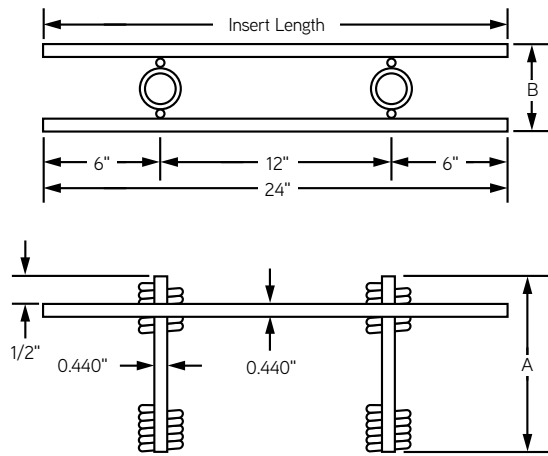

T11 Double End Pickup Insert

To Order:

Specify: (1) quantity, (2) name, (3) length, (4) struts.

Example:

200, T11 Single End Pickup Inserts, 1" dia. x 9" height, 4 struts.

T10 or T11 End Pickup Insert Selection Table

Insert Type	Bolt Diameter	No. of Struts Wires	Insert Length	Minimum Corner Distance	Safe Working Load Tension	Safe Working Load Shear	Minimum Panel Thickness	A	B
T10	1"	2	9"	11"	3,660lbs	1,300lbs	9"	9"	3-1/16"
T10	1-1/4"	2	10"	9"	3,870lbs	1,520lbs	10"	10"	3-5/16"
T10	1"	4	9"	11"	3,660lbs	1,680lbs	9"	9"	3-1/16"
T10	1"	4	12"	14"	5,540lbs	2,740lbs	12"	12"	3-1/16"
T10	1"	4	15"	18"	7,890lbs	3,950lbs	15"	15"	3-1/16"
T11	1"	2	9"	15"	7,250lbs	2,450lbs	9"	9"	3-1/16"
T11	1-1/4"	2	10"	15"	6,190lbs	2,740lbs	10"	10"	3-5/16"
T11	1"	4	9"	15"	8,730lbs	3,180lbs	9"	9"	3-1/16"
T11	1"	4	12"	19"	11,640lbs	4,570lbs	12"	12"	3-1/16"
T11	1"	4	15"	19"	12,390lbs	6,070lbs	15"	15"	3-1/16"

Safe working load provides a factor of safety of approximately 4 to 1 in 3,000 psi normal weight concrete.
 Safe working load based on 1/2" setback from face of concrete.

Lifting/Handling Inserts and Accessories

Proper Installation of T3 and T11 End Pickup Inserts

When using end pickup inserts, a 1/2" thick wood washer, length of plastic pipe or cut washers must be used against the ends of the loops. This is necessary so that when the lifting plate is tightened down, it will bear against the concrete and not against the loop ends. This procedure is necessary to develop the safe working load of the end pickup inserts. End pickup inserts must be located in the center of the panel structural thickness to obtain their safe working load.

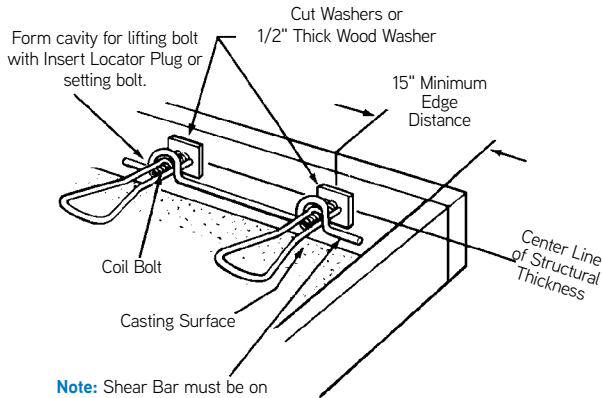

Note: Shear Bar must be on top of coils for T3 or T3A inserts.

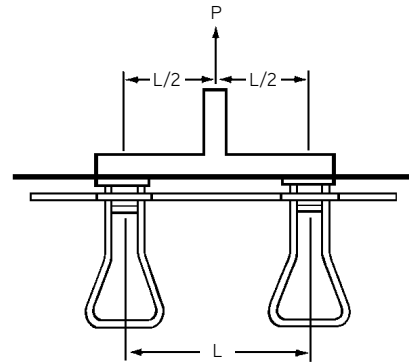

Note: To achieve Safe Working Load, Lifting Plate must be centered on T3 or T11 Insert

How To Determine Bolt Length

Always check to make certain that you have the proper clearance under the coil to prevent the lifting bolt from bottoming out against the concrete. You must be able to tighten the bolt securely to prevent the lifting hardware from slipping and applying unexpected loads to the insert.

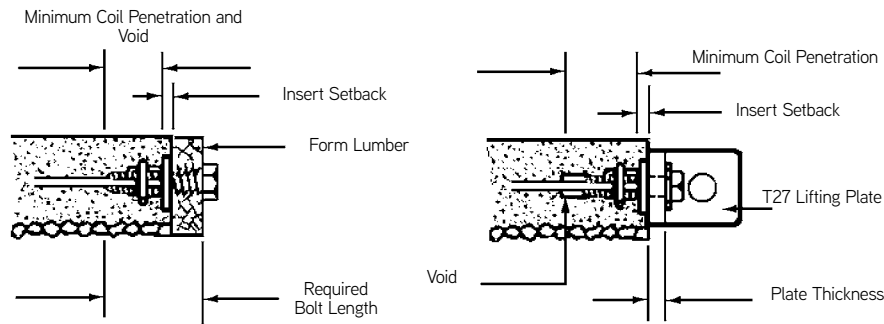

Setting Bolt

Lifting Bolt

Note: Face insert lifting bolt lengths are calculated in a similar manner to that shown above.

Safety Notes

- Coils must be perpendicular to the slab edge to achieve safe working loads shown.
- Inserts must be set back 1/2" from the concrete surface in order to achieve safe working loads shown.
- Coil bolt penetration must agree with minimums shown above.

Setting Bolt for Edge Inserts		Lifting Bolt for Edge Inserts	
Form Lumber	1-1/2"	T27 Plate Thickness	1"
Insert Setback	1/2"	Insert Setback	1/2"
Minimum Coil Penetration	2-1/2"	Minimum Coil Penetration	2-1/2"
Minimum Void	1/2"	Total Bolt Length	4"
Total Bolt Length	5"		

T12 Swivel Lifting Plate

- Designed for use with single pickup inserts.
- Can be used for face lifting or edge lifting.
- Complete unit made of forged steel.

T12 Swivel Lifting Plate

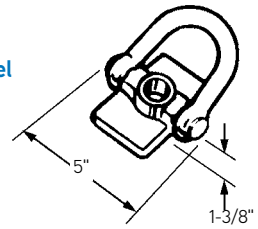

Safety Notes

- All plates must have full bearing on smooth, flat surfaces.
- Lifting plates must be used with a bolted fastener of sufficient strength to develop the required loads.
- Lifting plates are to be used only with the bolt diameter for which they were designed. For example, use a 3/4" bolt with a 3/4" T12 Swivel Lifting Plate, do not use a 3/4" bolt with a 1", 1-1/4" or 1-1/2" T12 Swivel Lifting Plate.
- All Plates must be securely fastened to slabs.
- For exposed aggregate panels, a grout pad is required to provide bearing for the plate.
- Coil bolt penetration must agree with minimums.

Type	Bolt Diameter	Loop Height	Safe Working Load	Bearing Plate Size
T12	3/4"	3.688"	7,200 lbs.	1/2 x 2-1/2" x 5"
	1"	3.688"	10,000 lbs.	
	1"	6.75"	10,000 lbs.	

Safe Working Load provides a factor of safety of approximately 5 to 1.

To Order:

Specify: (1) quantity, (2) name, (3) bolt diameter.

Example:

10, T12 Swivel Lifting Plates, 1" bolt diameter.

Lifting/Handling Inserts and Accessories

T21 Insert Locator Plugs

The Dayton Superior T21 Insert Locator Plug is a two piece plastic unit designed to engage the top and bottom of 3/4", 1", 1-1/4" and 1-1/2" diameter insert coils. The top piece has a protruding stem that marks the insert location. Plug removal is easily accomplished with a screw driver or similar device. The bottom portion of the plug forms a cavity for final bolt clearance. T21 plugs are available factory installed in the inserts or loose for field installation.

To Order:

Specify: (1) quantity, (2) name, (3) bolt diameter.

Example:

10, T21 Insert Locator Plug, 1-1/4" bolt diameter.

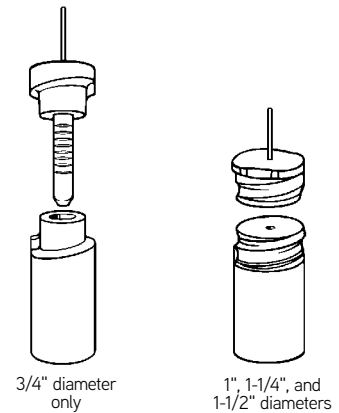

T21 Insert Locator Plugs

T26 Double Swivel Lifting Plate

- Designed for use with 1", 1-1/4" and 1-1/2" diameter coil bolts.
- Rotates 360° in horizontal plane and 180° in vertical plane.
- Round bearing plate provides maximum safety when used with any coil bolt lifting system.
- Heavy forged bail is made of high-strength material.
- Double swivel action allows bail to rotate in direction of applied load.
- Safe Working Load is 9,000 lbs. for 1" diameter.
- Safe Working Load is 13,500 lbs. for 1-1/4" and 1-1/2" diameter.

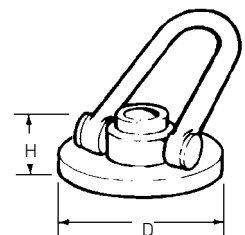

T26 Double Swivel Lifting Plate

Type	Bolt Diameter	H	D	Safe Working Load
T26	1"	2-11/16"	5"	9,000
T26	1-1/4"	2-3/4"	7"	13,500
T26	1-1/2"	2-3/4"	7"	13,500

Safe Working Load provides a factor of safety of approximately 5 to 1.

To Order:

Specify: (1) quantity, (2) name, (3) bolt diameter.

Example:

10, T26 Double Swivel Lifting Plate, 1-1/4" bolt diameter.

T27 Edge Lifting Plate

- Designed for use with T3 or T11 pickup inserts.
- Made from structural steel plate 1" x 4" x 18" long.
- Cut washers are required under head of all bolts.
- For use with 3/4" or 1" diameter bolts.
- For use on panels up to 6" thick; on panels thicker than 6", use T8.
- Safe Working Load is 8,800 lbs.

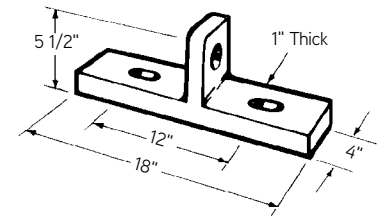

T27 Edge Lifting Plate

To Order:

Specify: (1) quantity, (2) name, (3) bolt diameter.

Example:

10, T27 Edge Lifting Plate, 1" bolt diameter.

Warning: Never use T27 with face lift inserts.

Dos and Don'ts

- Do not modify, weld or alter, in any way, lifting hardware units.
- Prior to lifting any precast element, apply an initial cable tension making certain that the bail or clevis attachment plate is aligned in the direction of the load at all times. Crane line loads must not be allowed to apply a sideward load to the bail or clevis attachment plate, as this condition is dangerous and could lead to a premature failure.

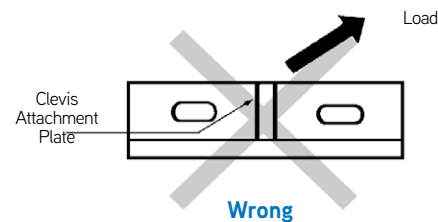
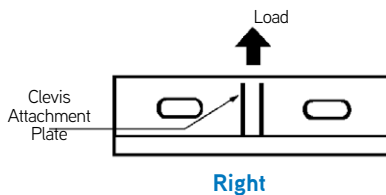

T8 Lifting or T27 Edge Lifting Plate

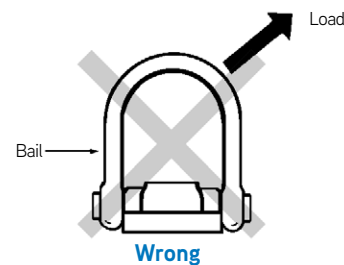
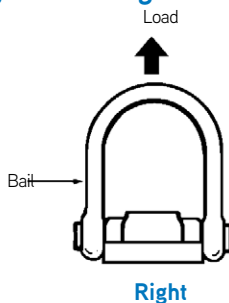

T12 Swivel or T26 Double Swivel Lifting Plates

Total System and Safe Working Loads

The user must be aware of the capacity of the total lifting system since the determination of the safe working load involves concrete strength and safe working loads of the insert, bolt and lifting hardware. All must be evaluated with the lowest safe load component determining the safe working load of the system. This handbook has such values listed in tabular form for all components, including the minimum concrete compressive strengths that must exist at time of use. Therefore, do not assume that an insert's safe working load is that of the system, since the Safe Working Loads of the bolt or lifting hardware may be less than that of the insert. Examine the values of all components.

Danger! Crane line loads and bails of swivel and double swivel lifting plates must be turned in direction of crane forces before lifting operations begin. Crane line loads must not be allowed to apply sideward loads to bails of Swivel Lifting Plates or Clevis Attachment Plates of Lifting Angle or Lifting Plate; this condition is dangerous and could lead to failure of hardware.

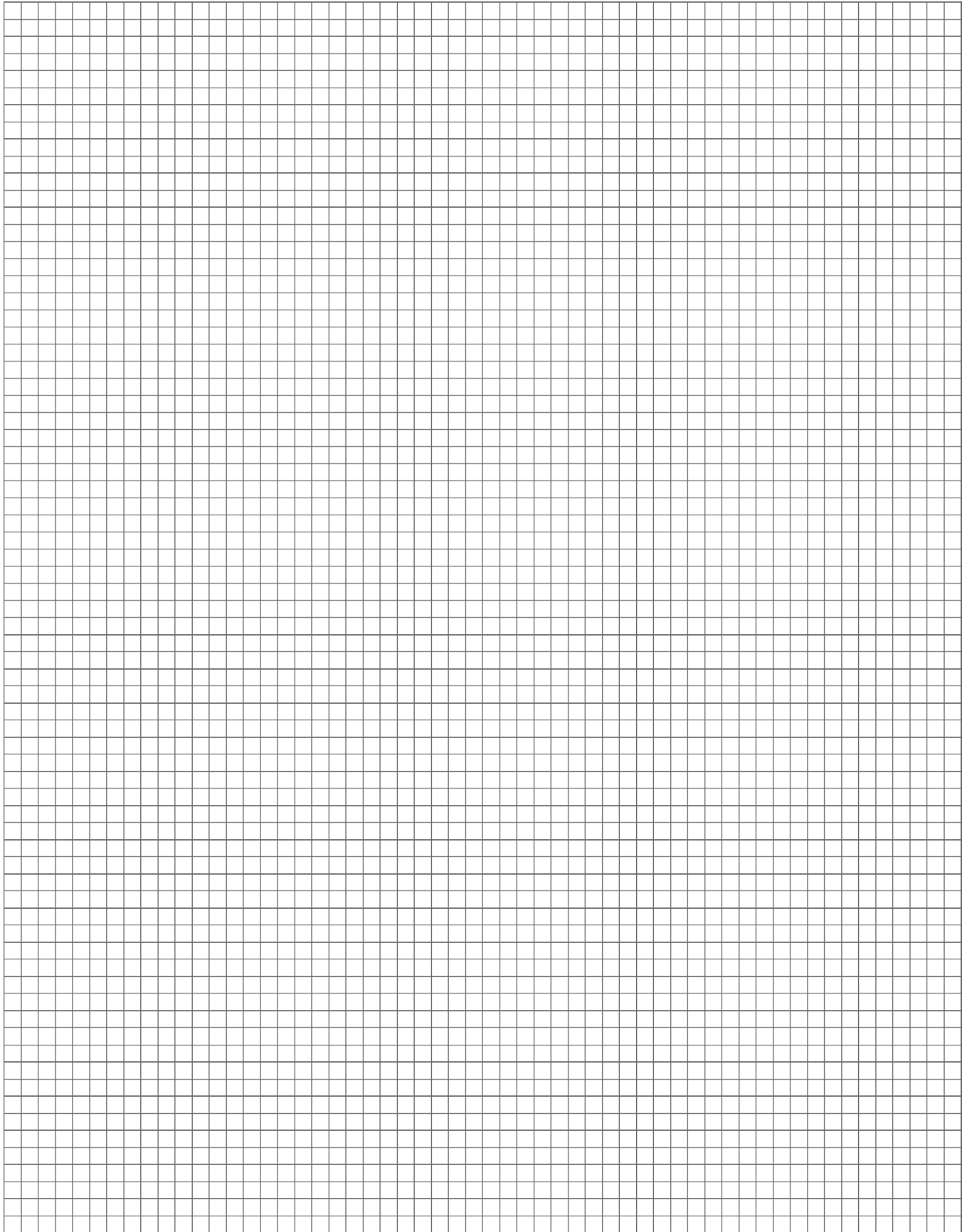

F5 Threaded Insert

The Dayton Superior F5 Threaded Inserts have National Course (NC) threads and are recommended for use under permanent loading conditions. This insert has been approved by the Board of Standards and Appeals for use in New York City under Calendar No. 447-60SM.

The F5 insert is cast from ductile iron that meets ASTM A-395, Grade 60-40-18.

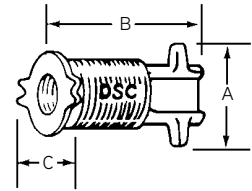

F5 Threaded Insert

F5 Threaded Insert Selection Table

Bolt Diameter and Threads per Inch	Tension Safe Working Load	Bolt Engagement	A	B	C
1/2" – 13	1,500 lbs.	15/16"	1-5/8"	2-1/2"	1-5/8"
5/8" – 11	2,000 lbs.	3/4"	1-5/8"	3"	1-5/8"
3/4" – 10	2,500 lbs.	7/8"	1-13/16"	3"	1-7/8"
7/8" – 9	3,000 lbs.	1-5/16"	2-1/2"	3-3/8"	2/5/8"
1" – 8	3,000 lbs.	1-5/16"	2-1/2"	3-3/8"	2/5/8"

Safe Working Load provides a factor of safety of approximately 3 to 1 when the insert is properly embedded in 3,000 psi normal weight concrete.

To Order:

Specify: (1) quantity, (2) name, (3) bolt diameter.

Example:

200, F5 Threaded Inserts, 3/4" bolt diameter.

F42 Loop Ferrule Insert

The Dayton Superior F42 Loop Ferrule Insert is fabricated by welding a looped strut to a closed-end ferrule. F42 insert is available in the sizes shown in the chart below and is well suited for structural connections and the suspension of equipment, piping, etc.

Minimum spacing between inserts is twice the minimum corner distance.

To Order:

Specify: (1) quantity, (2) name, (3) bolt diameter.

Example:

200, F42 Loop Ferrule Inserts, 3/4" bolt diameter.

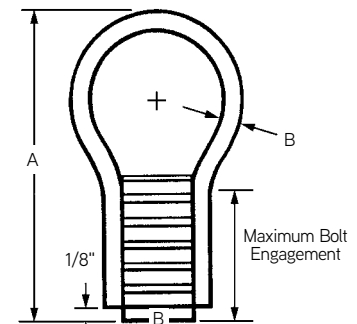

F42 Loop Ferrule Insert

F42 Loop Ferrule Insert Selection Table

Bolt Diameter and Threads per Inch	Minimum Edge Distance	Minimum Corner Distance	Safe Working Load Tension	Safe Working Load Shear	Maximum Bolt Engagement	A	B
1/4" – 20 NC	5"	5"	650 lbs.	650 lbs.	3/4"	2-3/4"	0.225
3/8" – 16 NC	5"	5"	2,000 lbs.	1,260 lbs.	3/4"	2-3/4"	0.225
	10"	15"	2,000 lbs.	2,000 lbs.			
1/2" – 13 NC	5"	5"	2,000 lbs.	1,280 lbs.	1"	2-3/4"	0.225
	7"	10"	2,000 lbs.	2,000 lbs.			
5/8" – 11 NC	5"	7"	2,200 lbs.	1,990 lbs.	1-1/8"	3-1/2"	0.262
	8"	8"	2,200 lbs.	2,200 lbs.			
3/4" – 10 NC	5"	7"	2,200 lbs.	1,990 lbs.	1-1/8"	3-1/2"	0.262
	8"	8"	2,200 lbs.	2,200 lbs.			
7/8" – 9 NC	8"	8"	5,300 lbs.	4,060 lbs.	1-1/8"	6"	0.375
	10"	15"	5,300 lbs.	5,300 lbs.			
1" – 8 NC	8"	8"	5,300 lbs.	4,060 lbs.	1-1/8"	6"	0.375
	10"	15"	5,300 lbs.	5,300 lbs.			

Safe Working Load provides a factor of safety of approximately 3 to 1 in 3,000 psi normal weight concrete. Safe Working Loads are based on 1/2" setback from face of concrete.

F43 Plain Ferrule

The Dayton Superior F43 Plain Ferrule (without loops) can be furnished for fabricating special inserts at the job site. Ferrules are manufactured from either 12L14 cold drawn carbon steel or Type 304 Stainless Steel. Contact your local welding service for proper welding techniques and instructions on welding either of these materials.

When ferrules are produced from Type 304 stainless steel, they will have a knurled rib, as shown. Ferrules that do not have any knurling are produced from 12L1K steel.

Minimum bolt engagement for ferrule inserts shall be equal to the nominal bolt diameter plus 1/8". The use of shorter bolt engagements will result in a lower than expected load carrying capacity.

All of the ferrules and ferrule inserts listed in this handbook are tapped with National Course (NC) threads. Dayton Superior can furnish, on special order, ferrules that are tapped with metric threads.

Note: All ferrules are made with a knock-out area in the closed bottom. When knocked out, the hole will accept a #8-32 self tapping screw that is used to attach ferrule inserts to the form face.

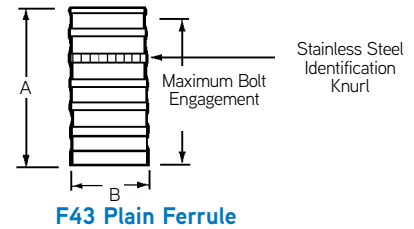

To Order:
Specify: (1) quantity, (2) name, (3) bolt diameter, (4) finish.

Example:
2000 pcs., F43 Plain Ferrules, 3/8" bolt diameter, type 304 SS.

F43 Plain Ferrule Selection Table

Bolt Diameter and Threads per Inch	Bolt Engagement	A	B
1/4" – 20 NC	3/4"	1-1/4"	9/16"
3/8" – 16 NC	3/4"	1-1/4"	9/16"
1/2" – 13 NC	1"	1-3/8"	11/16"
5/8" – 11 NC	1-1/8"	1-5/8"	7/8"
3/4" – 10 NC	1-1/8"	1-5/8"	1"
7/8" – 9 NC	1-1/8"	1-5/8"	1-1/4"
1" – 8 NC	1-1/8"	1-5/8"	1-3/8"
1-1/4" – 7 NC	1-3/4"	2-1/2"	1-5/8"
1-1/2" – 6 NC	2-1/4"	3"	1-7/8"

Structural Connectors

Special Ferrule Application

Many precasters have found that a 3/4"-10 NC threaded ferrule, when used as a nut in a special shop built insert, will solve many of their connection problems. The safe working loads of the ferrule (nut) when it is subjected to various bolt engagements are listed for your use.

Note: As the Ferrule SWL's listed are based on compression loading conditions, do not attempt to use these safe working loads with regular ferrule inserts.

Nominal Bolt Diameter and Threads per Inch	Minimum Bolt Engagement	Maximum Safe Working Load
3/4" - 10	1/4" 7 mm	5,500lbs. 24.4 kN
3/4" - 10	3/8" 10 mm	7,200lbs. 32.0 kN
3/4" - 10	1/2" 13 mm	8,700lbs. 38.6 kN
3/4" - 10	3/4" 19 mm	10,300lbs. 45.8 kN

The SWL's provide approximately a 3 to 1 factor of safety against thread stripping.

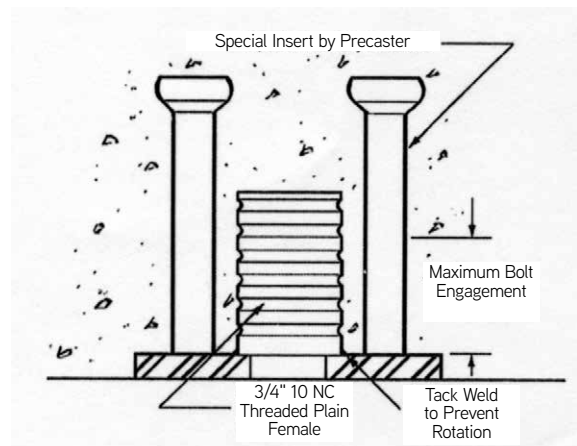

The SWL's listed in the table assume that the special precaster built insert has the capacity to safely support at least 3 times the ferrules safe working load.

F44 Thin Slab Ferrule Insert

The Dayton Superior F44 Thin Slab Ferrule Insert is a specially designed insert for use where the depth of embedment is extremely limited and where there is a requirement for limited capacity in both tension and shear. Depending on region, the F44 will be furnished with either two struts welded to the bottom of the ferrule or one strut looped around the ferrule (see sketch). Minimum spacing between inserts is twice the minimum corner distance.

F44 Thin Slab Ferrule Selection Table

Bolt Diameter and Threads per Inch	Safe Working Load Tension	Maximum Bolt Engagement	A	B
1/4" – 20 NC	450 lbs.	3/4"	1-1/4"	9/16"
3/8" – 16 NC	450 lbs.	3/4"	1-1/4"	11/16"
1/2" – 13 NC	900 lbs.	1"	1-3/8"	13/16"
5/8" – 11 NC	1,000 lbs.	1-1/8"	1-5/8"	1-1/16"
3/4" – 10 NC	1,600 lbs.	1-1/8"	1-5/8"	1-1/16"
7/8" – 9 NC	1,600 lbs.	1-1/8"	1-5/8"	1-1/16"
1" – 8 NC	1,600 lbs.	1-1/8"	1-5/8"	1-1/16"

Safe Working Load provides a factor of safety of approximately 3 to 1 in 3,000 psi normal weight concrete. Safe Working Loads are based on 1/2" setback from face of concrete.

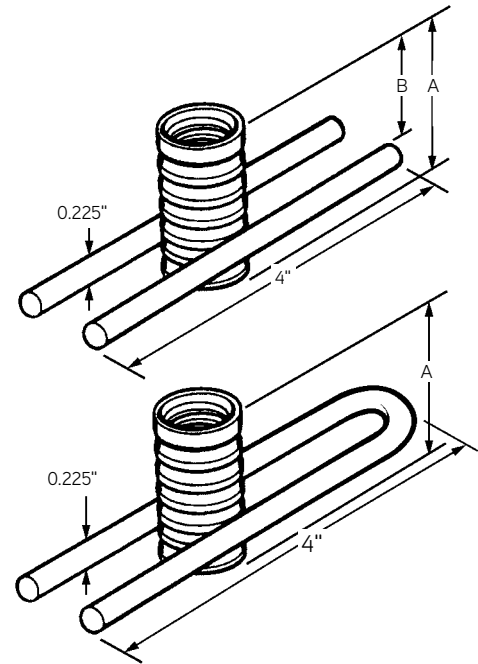

F44 Thin Slab Ferrule Inserts

To Order:

Specify: (1) quantity, (2) name, (3) bolt diameter, (4) finish.

Example:

200, F44 Thin Slab Ferrule Inserts, 1/2" bolt diameter, plain finish.

F45 Cap Plug

The Dayton Superior F45 Cap Plug is the least expensive device available for positioning NC threaded inserts. The Cap Plug is easily nailed to a wood form. Push an NC Threaded insert onto the plastic cap for a press fit.

If care is taken in the placement of concrete and in the use of vibrators, the F45 Plastic Plug is a satisfactory mounting device. Available for use with 3/8", 1/2", 5/8", 3/4", 1" and 1-1/4" National Course (NC) threaded inserts.

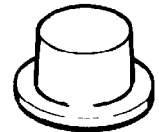

F45 Cap Plug

To Order:

Specify: (1) quantity, (2) name, (3) size.

Example:

200, F45 Cap Plugs, 1/2" diameter.

F50 Rocket/Kohler® Ferrule Insert

The Dayton Superior F50 Rocket Kohler Ferrule Insert is a two-strut ferrule insert with an extended length ferrule and integral washer face. The F50 insert is available in diameters from 1/4" through 1-1/4" and is well suited for structural connections or supporting hung ceilings, equipment, piping, etc.

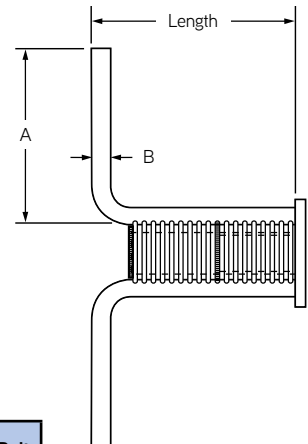

F50 Rocket/Kohler Ferrule Insert

To Order:

Specify: (1) quantity, (2) name, (3) bolt diameter, (4) finish.

Example:

200, F50 Rocket/Kohler Ferrule Insert, 1/2" bolt diameter, plain finish.

F50 Rocket/Kohler Ferrule Insert Selection Table

Bolt Diameter and Threads Per Inch	Insert Length	Minimum Edge Distance	Minimum Corner Distance	Safe Working Load Tension	Safe Working Load Shear	A	B	Maximum Bolt Engagement
1/4" – 20 NC	1-3/4"	4"	6"	750 lbs.	750 lbs.	1-3/4"	0.225"	1-1/4"
3/8" – 16 NC	1-3/4"	4"	6"	1,050 lbs.	1,350 lbs.	1-3/4"	0.225"	1-1/4"
1/2" – 13 NC	2-1/4"	6"	9"	1,575 lbs.	1,075 lbs.	2-1/4"	0.225"	1-3/4"
5/8" – 11 NC	3-3/8"	6"	11"	3,000 lbs.	3,000 lbs.	3-3/8"	0.312"	2-3/4"
3/4" – 10 NC	3-3/8"	6"	11"	3,000 lbs.	3,000 lbs.	3-3/8"	0.312"	2-3/4"
7/8" – 9 NC	3-3/4"	7"	12"	3,800 lbs.	3,800 lbs.	3-3/4"	0.340"	3-1/8"
1" – 8 NC	3-3/4"	7"	12"	3,800 lbs.	3,800 lbs.	3-3/4"	0.340"	3-1/8"
1-1/8" – 7 NC	4-1/4"	8"	14"	4,350 lbs.	4,350 lbs.	4-1/4"	0.340"	3-5/8"
1-1/4" – 7 NC	4-1/4"	8"	14"	4,350 lbs.	4,350 lbs.	4-1/4"	0.340"	3-5/8"

Safe Working Load provides a factor of safety of approximately 3 to 1 in 3,000 psi normal weight concrete. Safe Working Loads are based on 1/2" setback from face of concrete.

F52 Thin Slab Ferrule Insert

The Dayton Superior F52 Thin Slab Ferrule Insert is fabricated with four L-shaped struts resistance-welded to an NC thread ferrule. The F52 insert is available in 3/4" and 1" bolt diameters and in any height. Maximum insert safe working load is developed at an insert height of 5-1/2"

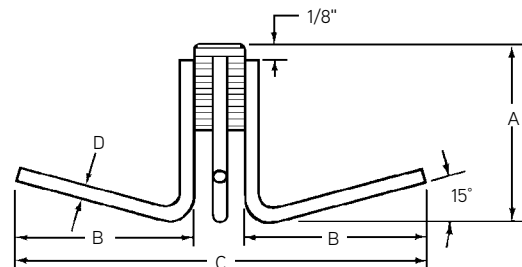

F52 Thin Slab Ferrule Insert

To Order:

Specify: (1) quantity, (2) name, (3) bolt diameter, (4) insert height, (5) finish.

Example:

200, F52 Thin Slab Ferrule Insert, 1" bolt diameter, 5-1/2" height, plain finish.

F52 Thin Slab Ferrule Insert Selection Table

Bolt Diameter and Threads Per Inch	Insert Length	Minimum Edge Distance	Minimum Corner Distance	Safe Working Load Tension	Safe Working Load Shear	A	B	C	D	Maximum Bolt Engagement
5/8" – NC	2-1/2"	6"	9"	2,006 lbs.	1,166 lbs.	2-1/2"	2-1/2"	6"	0.306	1-1/8"
3/4" – 10 NC	3-1/8"	8"	12"	3,680 lbs.	3,200 lbs.	3-1/8"	3"	7"	0.306"	1-1/8"
1" – 8 NC	4-1/8"	12"	18"	5,300 lbs.	5,300 lbs.	4-1/8"	4"	9-3/8"	0.306"	1-1/8"

Safe Working Load provides a factor of safety of approximately 3 to 1 in 3,000 psi normal weight concrete.

Structural Connectors

F54 Ductile Embed Insert

The Dayton Superior F54 Ductile Embed Insert is a one-piece, integrally hot forged unit fabricated out of smooth, round steel meeting ASTM A-29 Hot Rolled Grade 1045 requirements.

Insert top has a round washer face with four nail holes. The user can nail or bolt the insert to side forms or wet set in face of panel as required. The bottom end has a forged, washer-face hex foot to resist pullout from the concrete.

Use as a cast-in-place insert or in a core and grout insert application. Several inserts can be laced and/or templated together to provide preset anchorage patterns for closely-spaced multiple insert requirements.

Longer insert lengths are available when required. Minimum spacing between the inserts, shown in the chart, is twice the minimum corner distance.

Available plain, electro-galvanized, hot-dipped galvanized or epoxy coated as required.

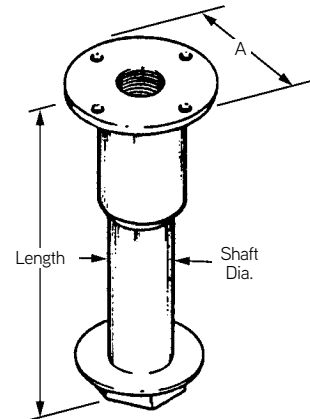

F54 Ductile Embed Insert

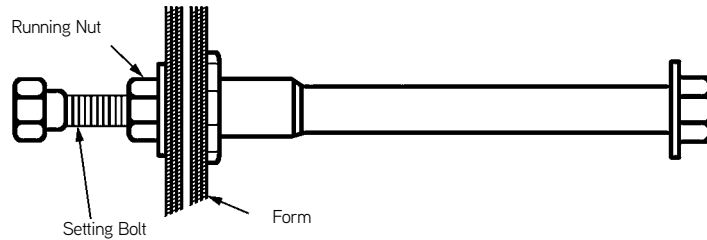
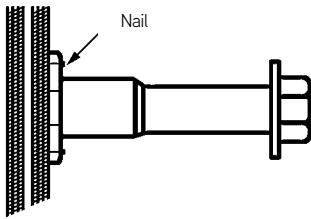

F54 Ductile Embed Insert Selection Table

Bolt Diameter and Threads per Inch	Shaft Diameter	Insert Length	Safe Working Load Tension	Safe Working Load Shear	Minimum Edge Distance	Minimum Corner Distance	Flange Diameter "A"	Maximum Bolt Engagement
5/8" – 11 NC	3/4"	7-1/2"	6,700 lbs.	4,310 lbs.	7-1/2"	15"	2"	15/16"
			9,030 lbs.	5,420 lbs.	10"	18"		
3/4" – 10 NC	7/8"	9"	8,800 lbs.	5,890 lbs.	9"	18"	2-1/4"	1-1/8"
			13,360 lbs.	8,020 lbs.	14"	20"		
7/8" – 9 NC	1"	10-1/2"	11,150 lbs.	8,050 lbs.	10-1/2"	18"	2-3/8"	1-5/16"
			18,350 lbs.	11,090 lbs.	16"	24"		
1" – 8 NC	1-1/8"	12"	13,790 lbs.	10,160 lbs.	12"	24"	2-1/2"	1-1/2"
			22,980 lbs.	14,540 lbs.	18"	30"		
1-1/4" – 7 NC	1-3/8"	15"	19,960 lbs.	15,570 lbs.	15"	30"	3-1/4"	1-7/8"
			33,150 lbs.	20,340 lbs.	24"	36"		

Safe Working Loads provide a factor of safety of approximately 3 to 1 in 3,000 psi normal weight concrete.

Safe Working Loads are based on 1/2" setback from the face of concrete.

Minimum spacing between inserts is twice the corner distance.

Note: Bolt diameter is 1/8" less shaft diameter all products.

To Order:

Specify: (1) quantity, (2) name, (3) shaft diameter, (4) overall length.

Example:

550, F54 Ductile Embed Insert, 3/4" x 9" long.

F57 Expanded Coil Ferrule Insert F59 Expanded Coil Ferrule Insert F61 Expanded Coil Ferrule Insert

The Dayton Superior Expanded Coil Ferrule Inserts were developed as a more effective means for increasing the insert's tensile capacity, without increasing its depth of embedment. By increasing the width of the base, the volume of the resisting shear cone is significantly increased. The expanded pitch coils welded to the more deeply embedded end of the insert serve to distribute the applied loads over a larger volume of concrete.

Available in longer lengths, as required. Minimum spacing between inserts is twice the corner spacing.

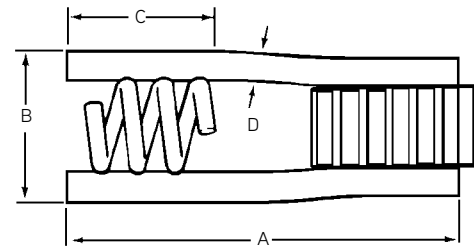

F57 Insert – 2 Struts
F59 Insert – 4 Struts
F61 Insert – 6 Struts

Expanded Coil Ferrule Loop Insert Selection Table

Insert Type	Bolt Diameter and Threads per Inch	Insert Length	Minimum Edge Distance	Minimum Corner Distance	Safe Working Load Tension	Safe Working Load Shear	A	B	C	D	Maximum Bolt Engagement
F57	3/4" – 10 NC	4-5/8"	6"	9"	4,650 lbs.	2,730 lbs.	4-5/8"	2-1/8"	1-1/2"	0.375"	1-1/8"
			14"	20"	5,890 lbs.	5,890 lbs.					
F57	1" – 8 NC	5-5/8"	8"	12"	6,990 lbs.	4,300 lbs.	5-5/8"	2-3/4"	2-1/4"	0.440"	1-1/8"
			16"	24"	8,100 lbs.	8,100 lbs.					
F59	1" – 8 NC	5-5/8"	8"	12"	7,465 lbs.	5,200 lbs.	5-5/8"	2-3/4"	2-1/4"	0.440"	1-1/8"
			18"	26"	13,310 lbs.	13,310 lbs.					
F59	1-1/4" – 7 NC	7-5/8"	10"	15"	9,920 lbs.	7,940 lbs.	7-5/8"	3"	2-3/4"	0.440"	1-3/4"
			18"	26"	13,310 lbs.	13,310 lbs.					
F61	1-1/2" – 6 NC	9-5/8"	12"	18"	13,180 lbs.	12,450 lbs.	9-5/8"	3-3/8"	3-5/8"	0.440"	2-1/4"
			22"	30"	18,680 lbs.	18,680 lbs.					

Safe Working Load provides a factor of safety of approximately 3 to 1 in 3,000 psi normal weight concrete.
Safe Working Loads are based on insert 1/2" setback from the face of concrete.
Minimum spacing between inserts is twice the corner.

To Order:

Specify: (1) quantity, (2) name, (3) bolt diameter, (4) finish.

Example:

200, F61 Expanded Coil Ferrule Inserts, 1-1/2" dia., plain finish.

F62 Flared Thin Slab Ferrule Insert

The F62 Flared Thin Slab Ferrule Insert was designed for use in thin precast concrete elements or for conditions where a longer insert cannot be used. This insert is closed at the back end of the ferrule to keep concrete from getting into the threads. The ferrule will accept only NC threaded bolts of appropriate diameters.

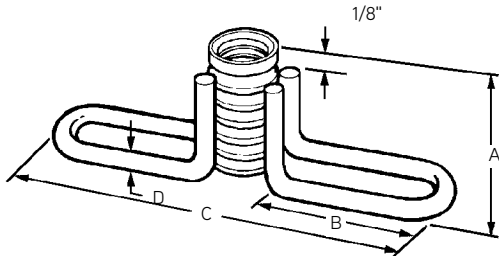

F62 Flared Thin Slab Ferrule Insert

To Order:

Specify: (1) quantity, (2) name, (3) bolt diameter, (4) insert height, (5) finish.

Example:

1,000 pcs., F62 Flared Thin Slab Ferrule Insert, 1" bolt x 2-7/16" high, plain finish.

F62 Flared Thin Slab Ferrule Insert Selection Table

Bolt Diameter and Threads per Inch	Insert Height A	Minimum Edge Distance	Minimum Corner Distance	Safe Working Load Tension	Safe Working Load Shear	B	C	D	Maximum Bolt Engagement
1/2" - 13 NC	1-3/4"	6"	9"	2,120 lbs.	2,120 lbs.	2"	4-3/4"	0.223"	1"
5/8" - 11 NC	2-7/16"	7"	10"	2,900 lbs.	2,900 lbs.	2"	4-3/4"	0.306"	1-1/8"
3/4" - 10 NC	2-7/16"	6"	9"	2,960 lbs.	2,960 lbs.	2"	4-7/8"	0.306"	1-1/8"
3/4" - 10 NC	3-5/8"	9"	14"	4,830 lbs.	4,830 lbs.	2"	4-7/8"	0.306"	1-1/8"
1" - 8 NC	2-7/16"	6"	9"	3,080 lbs.	3,080 lbs.	2-3/16"	5-1/8"	0.306"	1-1/8"
1" - 8 NC	4-5/8"	11"	16"	6,780 lbs.	6,780 lbs.	2-3/16"	5-1/8"	0.306"	1-1/8"

Safe Working Load provides a factor of safety of approximately 3 to 1 in 3,000 psi normal weight concrete.

Safe Working Loads are based on insert 1/2" setback from the face of concrete.

Minimum spacing between inserts is twice the corner.

F64 Ferrule Loop Insert

The Dayton Superior F64 Ferrule Loop Insert is manufactured by welding a wire loop to a steel ferrule which has been machined from bar stock. One end of the ferrule is closed, while the other end is drilled and tapped to accept an NC threaded bolt.

Typically, this insert is used to attach a precast wall panel to a building frame, as well as provide attachment of other structural elements that may be required.

Mounting Washer Option for all Ferrule Type Inserts

All ferrule type inserts are available with a 16 gauge x 2" x 2" mounting washer as an option. The mounting washer allows you to nail a ferrule type insert to the form.

To keep concrete from entering the threaded portion of an insert with mounting washer, cover the open face of the washer with duct tape.

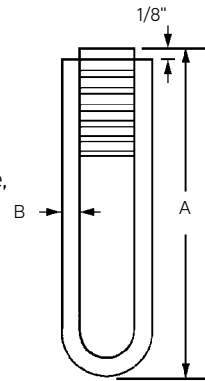

F64 Ferrule Loop Insert

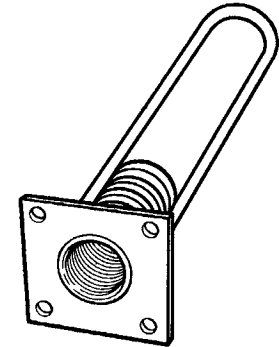

Insert with Optional Mounting Washer.

F64 Ferrule Loop Insert Selection Table

Bolt Diameter and Threads per Inch	Insert Height (A)	Minimum Edge Distance	Minimum Corner Distance	Safe Working Load Tension	Safe Working Load Shear	B	Maximum Bolt Engagement
1/2" – 13 NC	4-1/8"	5"	10"	3,000 lbs.	1,810 lbs.	0.223"	1"
		9"	15"	3,000 lbs.	3,000 lbs.		
1/2" – 13 NC	6-1/8"	7"	12"	5,000 lbs.	3,410 lbs.	0.306"	1"
		9"	12"	5,000 lbs.	3,410 lbs.		
5/8" – 11 NC	4-1/8"	5"	10"	3,000 lbs.	1,810 lbs.	0.223"	1-1/8"
		9"	12"	3,000 lbs.	3,000 lbs.		
5/8" – 11 NC	6-1/8"	7"	12"	5,000 lbs.	3,420 lbs.	0.306"	1-1/8"
		11"	15"	5,000 lbs.	5,000 lbs.		
		11"	15"	5,000 lbs.	5,000 lbs.		
3/4" – 10 NC	4-1/8"	5"	10"	3,000 lbs.	1,810 lbs.	0.223"	1-1/8"
		9"	12"	3,000 lbs.	3,000 lbs.		
3/4" – 10 NC	6-1/8"	7"	12"	5,000 lbs.	3,420 lbs.	0.306"	1-1/8"
		11"	15"	5,000 lbs.	5,000 lbs.		
7/8" – 9 NC	6-1/8"	7"	12"	5,000 lbs.	3,420 lbs.	0.306"	1-1/8"
		11"	15"	5,000 lbs.	5,000 lbs.		
1" – 8 NC	6-1/8"	7"	12"	5,000 lbs.	3,420 lbs.	0.306"	1-1/8"
		11"	12"	5,000 lbs.	4,650 lbs.		
1" – 8 NC	8-1/8"	7"	12"	5,000 lbs.	3,830 lbs.	0.306"	1-1/8"
		11"	15"	5,000 lbs.	5,000 lbs.		

Safe Working Load provides a factor of safety of approximately 3 to 1 in 3,000 psi normal weight concrete.

Safe Working Loads are based on 1/2" setback from the face of the concrete.

Minimum spacing between inserts is twice the minimum corner distance.

To Order:

Specify: (1) quantity, (2) name, (3) bolt diameter, (4) insert length, (5) finish.

Example:

200, F64 Ferrule Loop Insert, 5/8" bolt diameter, 6-1/8" insert length, plain finish.

F72 Threaded Setting Plug

The Dayton Superior F72 Threaded Setting Plugs eliminate the need for putting large holes in formwork in order to secure the inserts to the forms. Basically a socket set screw, it is drilled through and tapped with #8-32 thread. It can be nailed to wood forms, or bolted to steel forms using an #8-32 threaded bolt. The reusable plugs are easily removed using a standard hex wrench.

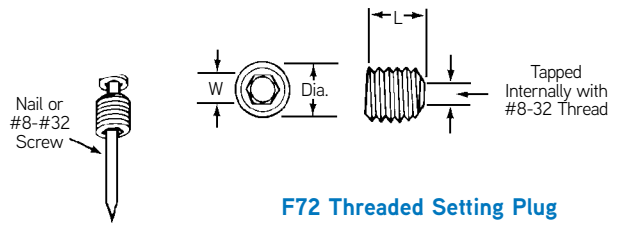

F72 Threaded Setting Plug

F72 Selection Table

Bolt Diameter and Threads per Inch	Dimensions	
	L	W
3/8" - 16 NC	3/8"	3/16"
1/2" - 13 NC	3/8"	1/4"
5/8" - 11 NC	1/2"	5/16"
3/4" - 10 NC	5/8"	3/8"
1" - 8 NC	1"	9/16"

To Order:

Specify: (1) quantity, (2) name, (3) diameter.

Example:

200, F72 Threaded Setting Plugs, 3/4" diameter.

F74 Threaded Plastic Plug

The Dayton Superior F74 Threaded Plastic Plug is manufactured with National Course (NC) threads to fit 3/8", 1/2", 5/8", 3/4", 7/8" and 1" NC threaded inserts. A hole is provided through the plug that may be used to attach (nail) the plug to the form.

To Order:

Specify: (1) quantity, (2) name, (3) bolt diameter.

Example:

200, F74 Threaded Plastic Plugs, 3/4" diameter.

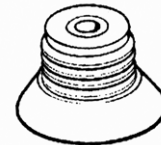

F74 Threaded Plastic Plug

P90 Connecting Systems Nylon Threaded Inserts

Dayton Superior P90 Connecting Systems Threaded Inserts are mineral-filled nylon inserts designed for attaching, suspending and fastening objects to precast concrete. They provide the precast manufacturer with an excellent, cost effective fastening system.

Advantages:

- Economical
- Light weight
- Easy to handle and use
- Available in five bolt diameters
- Can be used in hundreds of applications

Typical Applications:

- Lifting insert for light loads
- Secure handles of burial vaults
- Secure mechanical equipment to concrete pads
- Secure telephone booths to concrete pads
- Fasten cable holders to utility poles
- Secure benches, picnic tables and other landscape items to concrete bases
- Suspend pipes, conduits and other utilities from concrete panels and ceilings
- Plus many, many others

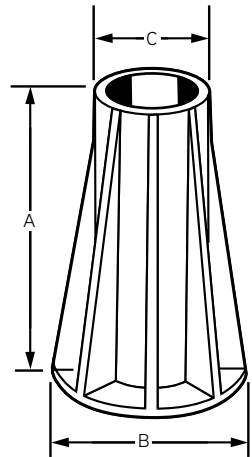
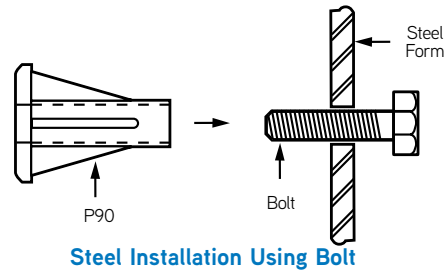

Bolt Diameter and Threads per Inch	Insert Length A	B	C	Minimum Edge Distance	Minimum Corner Distance	Safe Working Load Tension	Safe Working Load Shear
1/4" - 20 NC	1-1/2"	1"	3/4"	3"	6"	1272	763
3/8" - 16 NC	1-1/2"	1"	3/4"	3"	6"	1299	1251
1/2" - 13 NC	1-5/8"	1-3/8"	3/4"	3-1/2"	7"	1465	1465
1/2" -13 NC	2-5/8"	1-3/8"	3/4"	5-1/2"	11"	3007	3406
5/8" - 11 NC	3"	1-1/2"	7/8"	6"	12"	3674	4365
3/4" - 10 NC	3-1/4"	1-5/8"	1"	6-1/2"	13"	4143	4922

3:1 SF @ 5000 psi Concrete

D108A Headed Dowel Bar Insert

The Dayton Superior D108A Dowel Bar Insert is a one-piece unit integrally forged from material meeting ASTM A-615 Grade 60 requirements. This insert works extremely well in areas of heavy rebar congestion and provides excellent anchorage provisions for light standards, signs, posts, fixtures, etc. The D108A Headed Dowel Bar Insert is approved by the International Code Council, evaluation report ICC #4028.

The top of the insert has a round washer face with four nail holes. Nail or bolt insert to side forms or wet set in face of panel as required. The bottom end has a hot-forged, washer face hex foot to resist pull-out from the concrete.

Use this versatile insert as a cast-in-place insert or in a core and grout application. Lace and/or template several inserts together to provide repeat anchorage patterns of two, three, four or more inserts.

Longer length inserts are available as required. Minimum spacing between the inserts shown in the chart is twice the minimum corner distance.

Available plain, electro-galvanized, hot-dipped galvanized or epoxy coated as required.

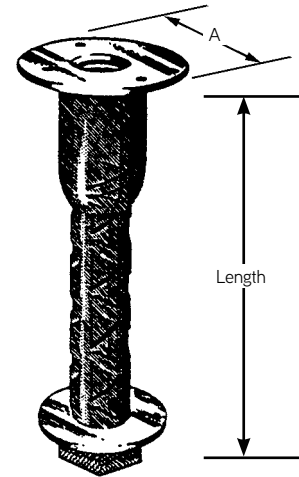

D108A Headed Dowel Bar Insert

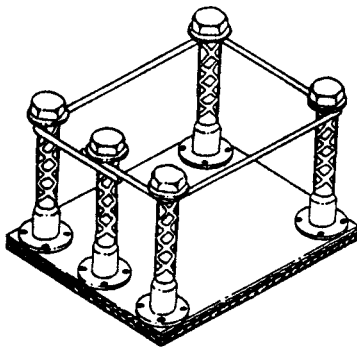

Laced and Template Application

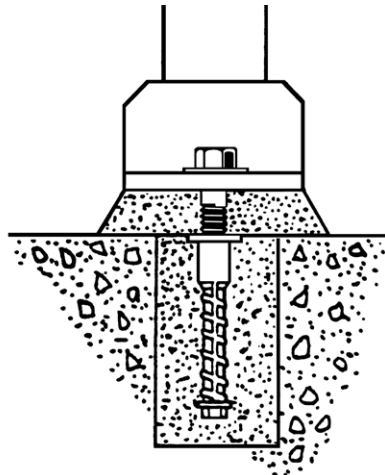

Core and Grout Application

To Order:

Specify: (1) quantity, (2) name, (3) bar size, (4) overall length, (5) finish.

Example:

300, D108A Headed Dowel Bar Insert, #5x7-1/2" long, plain finish.

D108A Headed Dowel Bar Insert Selection Table

Bolt Diameter and Threads per Inch	Shaft Diameter	Insert Length	Safe Working Load Tension	Safe Working Load Shear	Minimum Edge Distance	Minimum Corner Distance	Flange Diameter "A"	Maximum Bolt Engagement
5/8" - 11 NC	#4	7-1/2"	6,000 lbs.	4,000 lbs.	8"	12"	1-7/8"	7/8"
3/4" - 10 NC	#5	9"	9,300 lbs.	6,200 lbs.	11"	15"	2"	1"
7/8" - 9 NC	#6	10-1/2"	13,200 lbs.	8,800 lbs.	13"	20"	2-1/4"	1-1/8"
1" - 8 NC	#7	12"	18,000 lbs.	12,000 lbs.	16"	24"	2-7/16"	1-1/4"

Safe Working Load provides a factor of safety of approximately 3 to 1 in 3,000 psi normal weight concrete as calculated from criteria in ACI 318. Specific applications are the responsibility of the Engineer of Record, not Dayton Superior.

Minimum spacing between inserts is twice the corner distance.

Insert Length to bottom of bolt head.

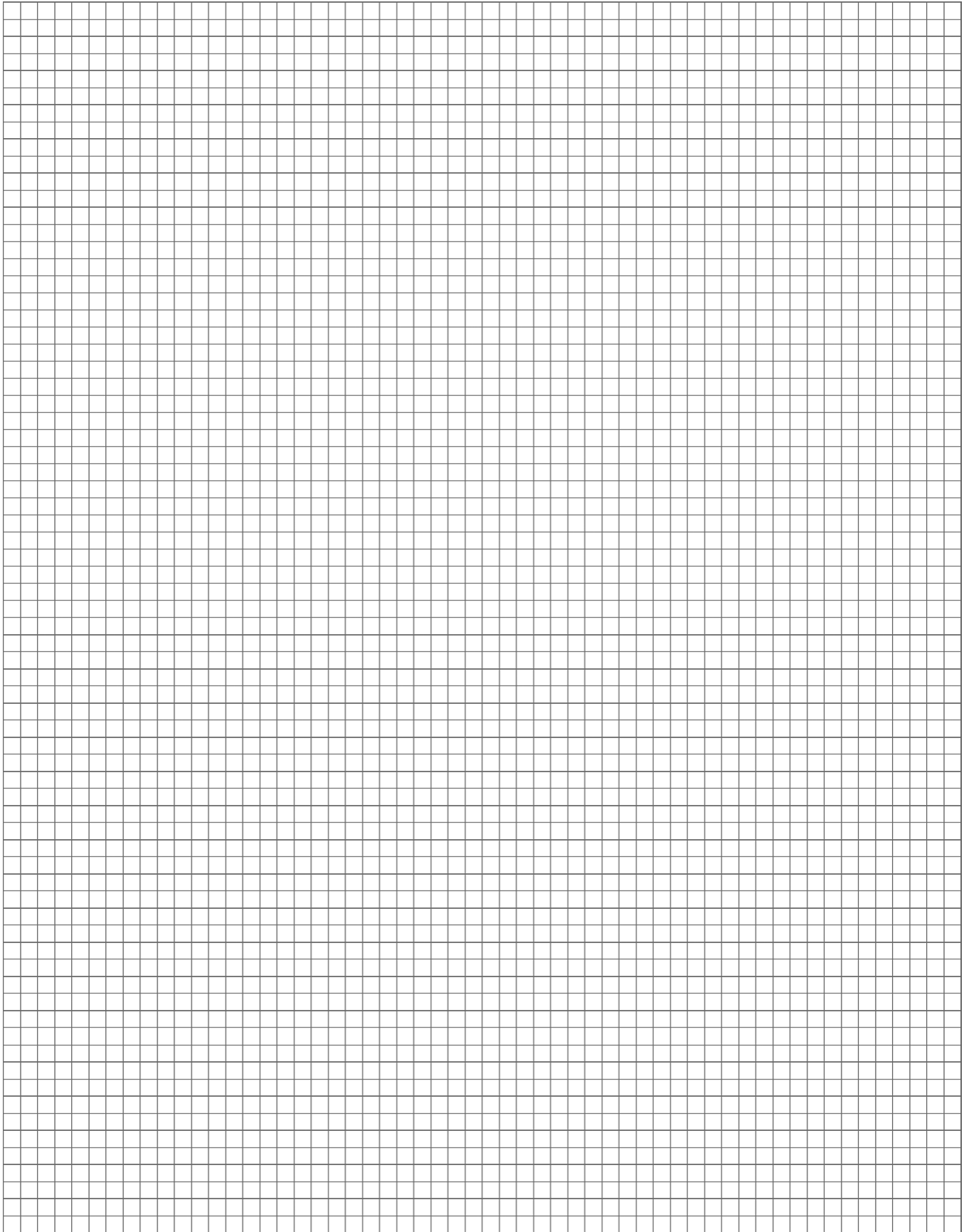

D410 Sleeve-Lock® Grout Sleeve

The Dayton Superior Sleeve-Lock Grout Sleeve is a one-piece mechanical coupler designed to butt-splice reinforcing steel in concrete structures. The Sleeve-Lock is available in seven (7) sizes to accommodate deformed bar sizes #4 through #18. Bars of like size or of different sizes can be effectively spliced by the System. Typical Sleeve-Lock applications include precast and cast-in-place concrete structures.

The Sleeve-Lock is a ductile casting with a minimum yield strength of 55,000 psi and a minimum tensile strength of 80,000 psi. It exceeds all known building codes and agency standards. The System achieves 160% f_y strength criteria with the Sleeve-Lock Grout D490 high strength, non-shrink grout.

The Sleeve has several unique features:

- Rebar Stop – An integrated post that acts as a precise stop when inserting rebar
- Alignment Fins – Positioning fins that keep inserted rebar centered
- Standard Port Sizes – Ports designed to accept standard 0.75" SCH40 PVC; ports use the same size PVC
- Stacking Feet – Feet used to stabilize the product during shipping and on the shelf while assisting in wire-tying and acting as a platform for a rebar chair.
- Made In USA – The sleeve is 100% made in the USA.

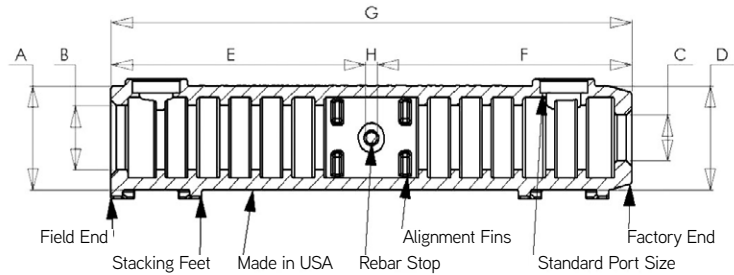

SIZE		SLEEVE-LOCK DIMENSIONS						REBAR EMBEDMENT LENGTH			
		A	B	C	D	G	H	E, MAX	E, MIN	F, MAX	F, MIN
#4	13MM	2.14	1.26	0.87	2.14	9.50	0.25	4.63	3.30	4.63	3.30
#5	16MM	2.14	1.26	0.87	2.14	9.50	0.25	4.63	4.13	4.63	4.13
#6	19MM	2.61	1.73	1.14	2.61	13.00	0.25	6.38	4.92	6.38	4.92
#7	22MM	2.61	1.73	1.14	2.61	13.00	0.25	6.38	5.71	6.38	5.71
#8	25MM	2.89	2.01	1.42	2.89	16.52	0.38	8.07	6.50	8.07	6.50
#9	29MM	2.89	2.01	1.42	2.89	16.52	0.38	8.07	7.40	8.07	7.40
#10	32MM	3.04	2.16	1.57	3.04	17.99	0.50	8.75	8.19	8.75	8.19
#11	36MM	3.32	2.32	1.73	3.32	19.54	0.50	9.52	8.98	9.52	8.98
#14	43MM	3.73	2.60	2.01	3.73	24.50	0.50	12.00	11.42	12.00	11.42
#18	57MM	4.77	3.27	2.68	4.77	36.00	0.50	17.75	17.00	17.75	17.00

All dimensions are in inches

D490 Sleeve-Lock® Grout

Sleeve-Lock Grout D490 is specifically designed and manufactured by DSC for the Sleeve-Lock System. It is a flowable grout capable of achieving 11,000ksi when mixed following the recommended mixing instructions of DSC. Available in 50lb bags, yield per bag, noting that grout used in PVC tubing is not accounted for, is as shown in table:

Use only potable water for mixing. A 50 pound (22.7 kg) of grout will require approximately 6.5 pints (3.07 liters) of water to achieve a flowable consistency. The water amount can be adjusted +/- 0.5 pints (0.23 liters) to achieve desired consistency. Determine correct water amount by mixing of a test batch prior to commencing grouting operation.

SIZE		SLEEVES PER BAG OF GROUT
#4	13MM	27
#5	16MM	28
#6	19MM	23
#7	22MM	16
#8	25MM	14
#9	29MM	12
#10	32MM	10
#11	36MM	8
#14	43MM	6
#18	57MM	3

Amounts are approximate.

D487 Sleeve-Lock® Seal Plug

The Sleeve-Lock Seal Plug is a rubberized plug used to seal the connection between the Sleeve-Lock Grout Sleeve and the reinforcing bar. It is designed to keep concrete from entering the inner cavity of the Sleeve-Lock Grout Sleeve on the Factory End and to contain the pumped in grout on the Field End. Per size, the Sleeve-Lock Seal Plug can be used on either end meaning that only one size Sleeve-Lock Seal Plug (QTY 2) per sleeve need be stocked.

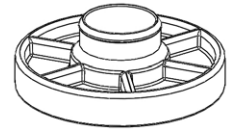

D491 Sleeve-Lock® Form Plug

The Sleeve-Lock Form Plug is a device using a rubberized grommet and a clamping device and used to attach the Sleeve-Lock Grout Sleeve to a piece of formwork i.e. steel, lumber, composite. It is designed to fasten the sleeve to the formwork while keeping concrete out of the sleeve's inner chamber. It is to be used on the Field End only and is not designed to be used as a structural connection.

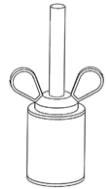

D492 Sleeve-Lock® 3/4" SCH40 PVC

The Sleeve-Lock 3/4" SCH40 PVC is standard, off the shelf, PVC, used to fill the inner chamber of the Sleeve-Lock Grout Sleeve. Either port of the sleeve uses the same size PVC. It is available locally or through DSC.

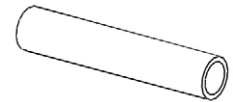

D493 Sleeve-Lock® Port Plug

The Sleeve-Lock Port Plug is a plastic plug used during jobsite shipping to plug the ports in order to keep debris from entering the inner chamber of the sleeve. They can also be used to plug the PVC before or after grouting. One size will fit either end port or PVC.



How to Specify:

Specific: Mechanical splices shall be the Sleeve-Lock® Grout Sleeve System manufactured by Dayton Superior Corporation.

Generic: The mechanical connection shall meet building code requirements of developing in tension and compression, as required, by local standards and codes. Grouting must be performed in accordance with the manufacturer's recommended grouting procedures.

Dowel Bar Splicer System*

ICC Evaluation Report No. 4028

The Dayton Superior Dowel Bar Splicer System is a two-piece, standard mechanical splicing technique (splicing bars of equal size) that eliminates protruding dowels. Typical applications include splicing reinforcement bars in precast structures, rebar anchorages, future expansion, and dowel bar substitution at construction joints.

The components of the system, the Splicer and Dowel-In, are manufactured from standard grade 60 rebar material. Basic fabrication consists of forging and threading operations. No welding or machining is required and the threading operation does not reduce the nominal cross-sectional area of the bar. The completed splice (joined Splicer and Dowel-In) obtains ultimate bar strengths and meets or exceeds all existing code requirements including 160% f_y or 95% of bar actual tensile requirements as identified by ICC acceptance criteria AC 133.

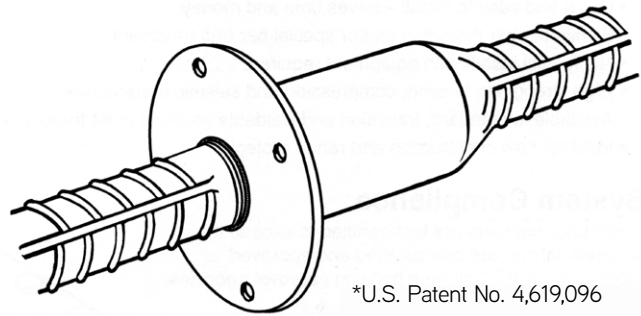

System Advantages

The patented Dowel Bar Splicer System has been engineered, tested and proven to meet or exceed all field standards and design/engineering practices. The System is strong, easy to use and readily identified as rebar material. The easy installation requires no special tools or machinery and simplifies the forming operations. There are no “extras,” such as wedges, nuts, collars or couplers required and routine cutting, bending, etc., can be easily handled in the field, if required.

The Dayton Superior Dowel Bar Splicer System Advantages:

- Strong
- Safe
- Easy to Use
- Eliminates Protruding Dowels
- Improves Forming Costs
- Reduces Forming and Stripping Hassles
- Saves Forms By Eliminating Drilling Holes
- No Forming Required

System Compliance

The Dowel Bar Splicer System complies with the following standards/specifications:

- International Conference of Building Officials (ICC Report #4028)
- City of Los Angeles Research Report RR 24518
- American Concrete Institute (ACI Standard 318)
- State Departments of Transportation
- Corps of Engineers (Specification CW03210)

Typical Splicing Specification

The Dayton Superior Dowel Bar Splicer System, consisting of the Dowel Bar Splicer and Dowel-In, shall be used in splicing of rebar. The Dowel Bar Splicer shall be forged from ASTM A-615 grade 60 deformed rebar material, free of external welding and machining. It shall be furnished with an integral nailing flange and threaded with UNC or UN thread to a depth equal to the nominal thread diameter. The Dowel-In shall be fabricated from ASTM A-615 grade 60 deformed rebar material with thread corresponding to the Splicer. The completed splice shall meet 160% f_y exceeding tensile requirements of American Concrete Institute Specification 318, *Building Code Requirements for Reinforced Concrete* and the Corps of Engineers Specification CW03210, *Civil Works Construction Guide Specification for Steel Bars, Welded Steel Wire Fabric and Accessories for Concrete Reinforcement*.

Note: For more information on the threaded Dowel Bar Splicer System, request a copy of the Dayton Superior Rebar Splicing Handbook

Dayton Superior Bar Lock® Coupler System*

ICC Evaluation Report No. 5064

The Dayton Superior Bar-Lock Coupler System provides a simple, quick, cost effective method for splicing rebar in tension and/or compression applications. Bar-Lock couplers may be used with plain or deformed bars in sizes #4 through #18.

Bar Lock couplers utilize lock-shear bolts and special grip rails to mechanically splice with the rebar. The serrated grip rails cradle the rebar and are embedded in the rebar as the lock-shear bolts are tightened. The heads of the lock-shear bolts are designed to shear off at a prescribed torque in order to accomplish proper installation.

System Advantages:

- Quick and easy to install – saves time and money.
- Eliminates bar threading and/or special bar end treatment.
- No special installation equipment required.
- High strength in tension, compression and seismic applications.
- Available in standard, transition and weldable versions in #4 through #18 sizes.
- Ideal for new construction and rehab projects.

System Compliance

Bar-Lock couplers are test-certified to exceed the requirements of, are pre-qualified and approved, or recognized by the following building approval agencies:

- State Departments of Transportation
- International Conference of Building Officials (ICC)
- Building Officials and Code Administrators (BOCA)
- Southern Building Code Congress International (SBCCI)
- American Concrete Institute (ACI)
- Concrete Reinforcing Steel Institute (CRSI)
- City of Los Angeles Department of Building and Safety

Bar-Lock coupler source material is fabricated under ISO9000 quality standards. Bar-Lock couplers are tested by independent, certified testing laboratories in four modes of testing: tension, compression, fatigue and cyclic. All tests are done to the requirements of ICC and/or Caltrans requirements utilizing ASTM A615 grade 60 rebar material. Copies of test reports are available on request.

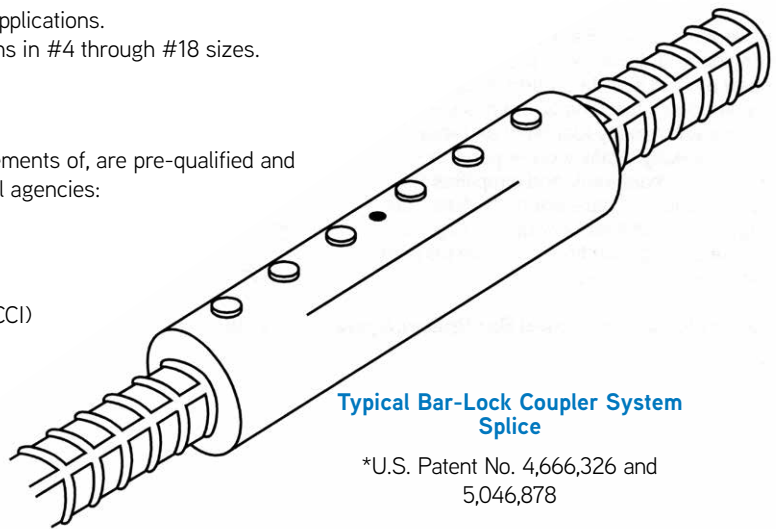

Typical Bar-Lock Coupler System Splice

*U.S. Patent No. 4,666,326 and 5,046,878

Typical Specification

By specific name:

Bar Lock Mechanical Coupler System manufactured by Dayton Superior Concrete Accessories.

By generic description:

Mechanical butt splices utilizing lock-shear bolts and internal serrated grip rails within the coupling sleeve. They shall exceed the specification requirements for both tension and compression specified by ACI 318 and the Uniform Building code, and be recognized by the International Conference of Building Officials (ICC).

Note: For more information on the Bar Lock Coupler System, request a copy of the Dayton Superior Rebar Splicing Handbook

F11 Hanger Insert and F12 Hanger Hook

One of the more economical and effective devices for providing points of anchorage for suspended ceilings is the hanger insert that can be fastened to a beam soffit by nailing or taping. The metal shell provides a cavity and the wire clip provides the anchorage for the attachment of ceiling suspension wires. If preferred, the Hanger Hook provides a simple method for the attachment of perforated metal hanger straps that can be used for the support of pipe, conduit, etc. Both insert and hook are fabricated from galvanized material. The F12 Hanger Hook is available with 9/32" or 13/32" holes.

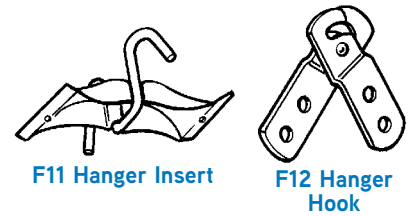

To Order:

Specify: (1) quantity, (2) name, (3) hole size in F12.

Example:

200 each, F11 Hanger Inserts and F12 Hanger Hooks, 9/23" holes.

P30 Corewall® Nut Type Slotted Insert

P31 Corewall® Strap Type Slotted Insert

COREWALL Slotted Inserts and accessories are engineered for performance and have proven to be one of the most advanced, adjustable inserts available on the market today. The slotted inserts feature a plastic back and a removable plastic slot cover that keeps the insert clean and saves you valuable time during the erection process.

COREWALL slotted inserts from Dayton Superior are available in two different types, the P30 Nut Type Slotted Insert and the P31 Strap Type Slotted Insert. Both types have tabs on each end of the insert for easy attachment to your forms.

The P30 Nut Type Slotted Insert uses a spring loaded, zinc-plated, heavy duty 3/4"-10 National Course (NC) threaded nut to provide fast, efficient and reliable connections. The P31 Strap Type Slotted Insert is used with either the P32 Standard Strap Anchor or the P33 Slotted Strap Anchor, depending upon your erection requirements. The P34 Threaded Strap Anchor is used with the P30 Nut Type Slotted Insert.

The design of the strap anchor allows for fast installation of the anchor into the slotted insert. This speeds up the erection process and saves valuable installation time. As part of the erection process, the strap anchor is welded to the building's structural frame to make a ductile connection. All COREWALL products are manufactured from a weldable grade of steel.

Dayton Superior COREWALL slotted inserts are ideal for use in precast concrete industrial wall panels, architectural panels, structural panels or precast parking structures. The COREWALL slotted inserts are also suitable for use in seismic areas.

P31 Strap Type Slotted Insert

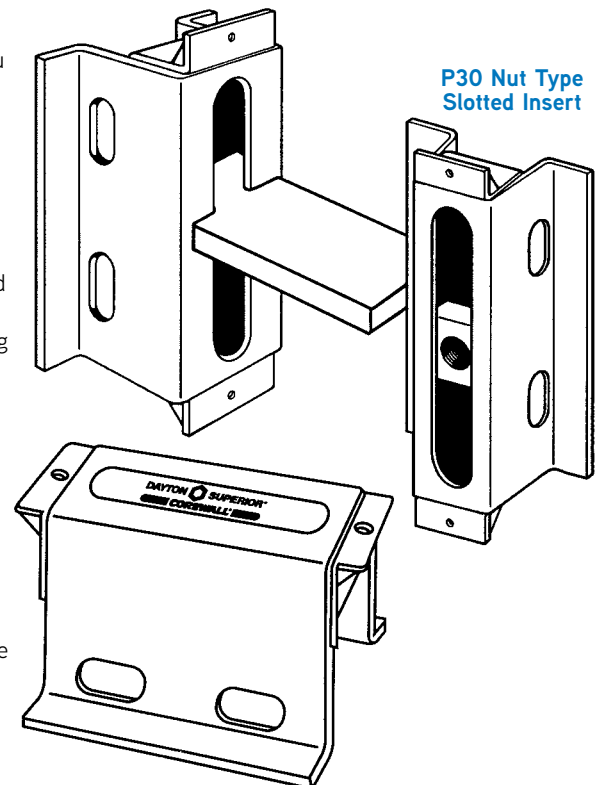

Fast, High Strength, Reliable
Concrete Connection Inserts

P30 Corewall® Nut Type Slotted Insert

The Dayton Superior P30 Nut Type Slotted Insert uses a spring loaded, zinc plated, heavy duty 3/4"-10 NC threaded nut to provide fast, efficient and reliable connections. The P30 insert can be used with standard NC threaded bolts or a P34 Threaded Strap Anchor, if a welded connection is required. P30 inserts are available in 4", 6" and 8" standard lengths with either blue epoxy-polyester or hot dipped galvanized (HDG) finish. Type 304 or 316 stainless steel is available on request.

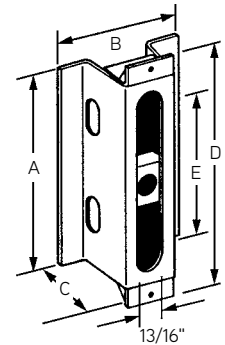

P30 Corewall Slotted Insert Nut Type

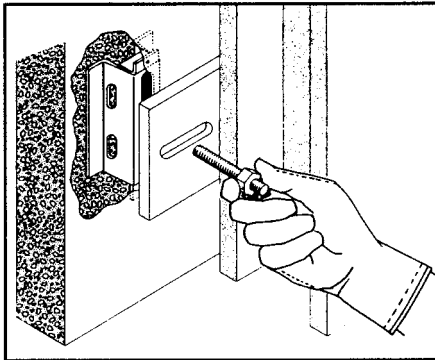

For proper connection to the structural frame of the building, use either a 3/4"-10 NC threaded bolt or rod meeting ASTM A-325 or SAE Grade 5 Standards.

To Order:

Specify: (1) quantity, (2) name, (3) part number, (4) finish.

Example:

200, P30 Corewall Nut Type Slotted Inserts, #CS425, hot-dip galvanized.

P30 Corewall Nut Type Slotted Insert Selection Table

Product Code	Tension Safe Working Load	Shear Safe Working Load	A	B	C	D	Adjustment E
CS425	4,000 lbs.	6,650 lbs.	4"	3-3/16"	2-1/2"	5-1/2"	2-1/2"
CS625	4,000 lbs.	6,650 lbs.	6"	3-3/16"	2-1/2"	7-1/2"	4-1/2"
CS825	4,000 lbs.	6,650 lbs.	8"	3-3/16"	2-1/2"	9-1/2"	6-1/2"
CS435	5,350 lbs.	6,650 lbs.	4"	3-3/8"	3-1/2"	5-1/2"	2-1/2"
CS635	5,350 lbs.	6,650 lbs.	6"	3-3/8"	3-1/2"	7-1/2"	4-1/2"
CS835	5,350 lbs.	6,650 lbs.	8"	3-3/8"	3-1/2"	9-1/2"	6-1/2"
CS445	6,650 lbs.	6,650 lbs.	4"	3-11/16"	4-1/2"	5-1/2"	2-1/2"
CS645	6,650 lbs.	6,650 lbs.	6"	3-11/16"	4-1/2"	7-1/2"	4-1/2"
CS845	6,650 lbs.	6,650 lbs.	8"	3-11/16"	4-1/2"	9-1/2"	6-1/2"

Safe Working Loads provide a factor of safety of approximately 3 to 1 in 5,000 psi normal weight concrete.

P31 Corewall® Strap Type Slotted Insert P32 Corewall® Strap Anchor

The P31 Corewall Strap Type Slotted Insert and the P30 Corewall Nut Type Slotted Insert are both quick and versatile precast concrete connection inserts. When used with the slot running in the same direction as the applied load, the inserts act as a tension tie to the structural frame. However, when the inserts are installed so that the slot runs 90° to the applied load, the inserts can support both shear and tension loads.

See following pages for the minimum edge distance requirements needed to develop the tension and shear safe working loads shown in the table below.

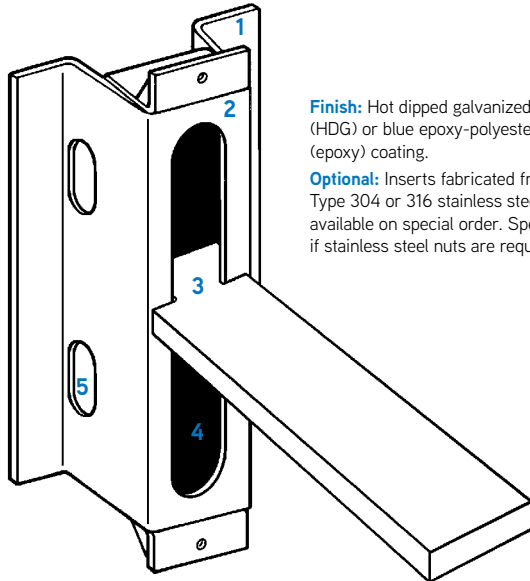

Finish: Hot dipped galvanized (HDG) or blue epoxy-polyester (epoxy) coating.
Optional: Inserts fabricated from Type 304 or 316 stainless steel are available on special order. Specify if stainless steel nuts are required.

P31 Corewall Strap Type Slotted Insert

P32 Corewall Strap Anchor

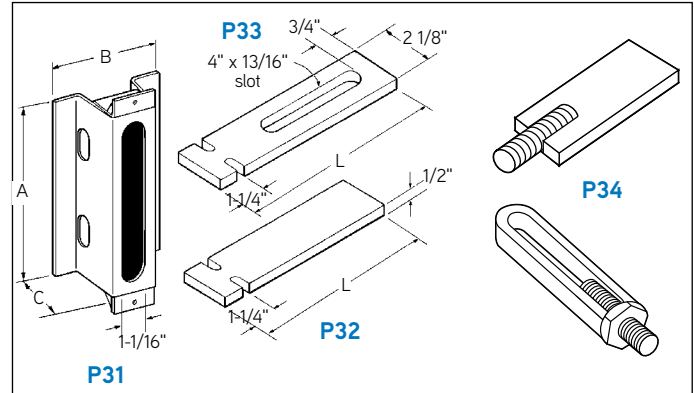

1. Tabs for easy attachment to forms.
2. Weldable grade of steel.
3. Notch in strap anchor assures positive connection to insert.
4. Slot allows adjustment for erection tolerances.
5. Slotted holes for extra reinforcement where required.

P31 Corewall Strap Type Slotted Insert Selection Table

Insert Style	Tension Safe Working Load	Shear Safe Working Load		A	B	C
		Up to 2' Eccentricity	Up to 3' Eccentricity			
SA 1425	4,000 lbs.	6,650 lbs.	4,000 lbs.	4"	4-3/16"	2-1/2"
SA 1625	4,000 lbs.	6,650 lbs.	4,000 lbs.	6"	4-3/16"	2-1/2"
SA 1825	4,000 lbs.	6,650 lbs.	4,000 lbs.	8"	4-3/16"	2-1/2"
SA 1435	5,350 lbs.	6,650 lbs.	4,000 lbs.	4"	4-3/8"	3-1/2"
SA 1635	5,350 lbs.	6,650 lbs.	4,000 lbs.	6"	4-3/8"	3-1/2"
SA 1835	5,350 lbs.	6,650 lbs.	4,000 lbs.	8"	4-3/8"	3-1/2"

Safe Working Load provides a factor of safety of approximately 3 to 1 in 5,000 psi normal weight concrete. Eccentricity is measured from face of insert to midpoint of the weld connecting the strap anchor to the structural frame.

Corewall Strap Anchor Selection Table

P32 Standard Strap Anchor		P33 Slotted Strap Anchor		P34 Threaded Channel Strap Anchor		P34 Threaded Plate Strap Anchor	
Part Number	Length	Part Number	Length	Part Number	Length	Part Number	Length
CE 806	6"	CE 906	6"	CE 675	6"	CE 600	6"
CE 808	8"	CE 908	8"	CE 875	8"	CE 800	8"
CE 810	10"	CE 910	10"	CE 1075	10"	CE 1000	10"
CE 812	12"	CE 912	12"	CE 1275	12"	CE 1200	12"

Note: Longer lengths are available on special order. The P34 Threaded Strap Anchor is used with the P30 Nut Type Slotted Insert and P38 Slotted Insert II.

P38 Corewall® Slotted Insert II

Product Description:

The Corewall Slotted Insert II is the next generation product in the Corewall legacy. The design has been improved to create a higher load capacity and greater ease to install the product. With six different product options and two different finishes, the Corewall Slotted Insert II will meet any application. This product is an addition to the Corewall Slotted Inserts which have been specified and used by precasters for over 20 years. The existing styles of Corewall Inserts remain available for use as well.

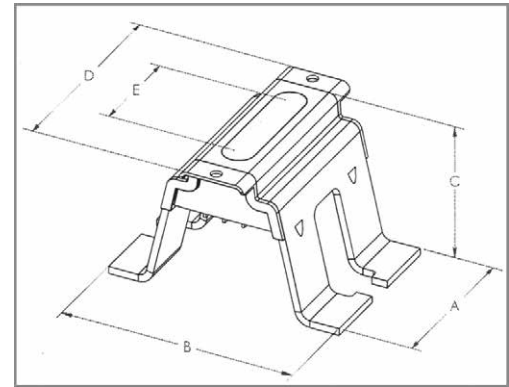

PRODUCT SPECIFICATION:

- 7 gauge one piece steel tampered body
- One piece plastic void former and removable plastic cap
- 3/4" - 10 special nut design
- 3 Insert heights - 2.5", 3.5", and 4.5"
- 3 Insert lengths - 4", 5", 6"
- P34 Threaded Strap Anchor for attachment to building frame

TECHNICAL DATA:

P38 Nut Type Slotted Anchor Insert Selection Table

Description	Tension Safe Working Load	Shear Safe Working Load	Length (A)	Width (B)	Depth (C)	Length (D)	Adjustment (E)
2.5" x 4" P38	4,660 lbs.	5,150 lbs.	4"	5-1/2"	2-1/2"	5-1/4"	2-1/2"
2.5" x 6" P38	5,500 lbs.	6,400 lbs.	6"	5-1/2"	2-1/2"	7-1/4"	4-1/2"
2.5" x 8" P38	5,500 lbs.	7,300 lbs.	8"	5-1/2"	2-1/2"	9-1/4"	6-1/2"
3.5" x 4" P38	6,300 lbs.	8,600 lbs.	4"	6"	3-1/2"	5-1/4"	2-1/2"
3.5" x 6" P38	6,750 lbs.	8,700 lbs.	6"	6"	3-1/2"	7-1/4"	4-1/2"
3.5" x 8" P38	7,100 lbs.	8,700 lbs.	8"	6"	3-1/2"	9-1/4"	6-1/2"
4.5" x 4" P38	8,600 lbs.	10,700 lbs.	4"	6-1/2"	4-1/2"	5-1/4"	2-1/2"
4.5" x 6" P38	8,800 lbs.	10,950 lbs.	6"	6-1/2"	4-1/2"	7-1/4"	4-1/2"
4.5" x 8" P38	9,100 lbs.	10,950 lbs.	8"	6-1/2"	4-1/2"	9-1/4"	6-1/2"

Safe Working Loads provide a factor of safety of approximately 3 to 1 in 5,000 psi normal weight concrete. Engineer is responsible to make sure that connecting threaded rod or bolt is strong enough to carry these loads.

To Order:

Specify: (1) quantity, (2) name, (3) part number, (4) description, (5) finish.



4.5" x 6" Insert with J-Coating finish

Corewall® Edge and Corner Details

Minimum edge distance, without the use of additional reinforcing steel, is shown below. Edge distance can be reduced if additional reinforcing steel is installed in the insert slots, as shown.

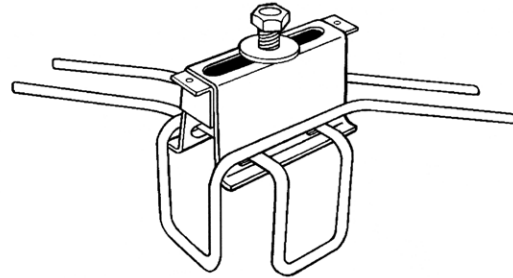
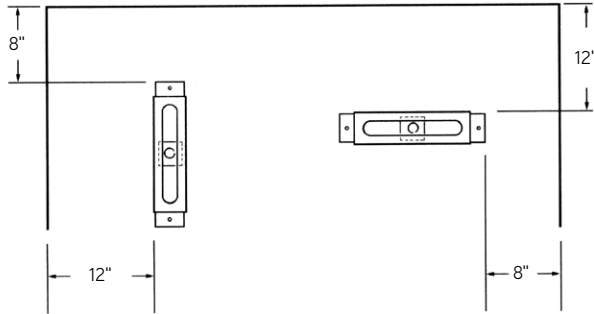

A variety of configurations of extra reinforcing bars can be easily placed through the slotted holes in the legs of the insert. This will allow the insert to be used in seismic areas, as well as close to corners or edges of a precast concrete panel.

<p>Corner Detail-</p> <p>Plan</p> <p>Section</p>	<p>Edge Perpendicular Detail</p> <p>Plan</p> <p>Section</p>	<p>Slot Details</p> <p>4" Insert</p> <p>6" Insert</p> <p>8" Insert</p>
<p>Edge Parallel Detail-</p> <p>Plan</p> <p>Section</p>	<p>Corner Detail-</p> <p>Plan</p> <p>Section</p>	<p>Stepped Hairpin</p> <p>Half Stepped Hairpin</p>

Miscellaneous Connection Inserts

P39 Corewall® Generation III Insert

Dayton Superior P39 Corewall Generation III Insert is the next generation product in the Corewall legacy. This insert is an economical way to connect precast panel to panel or panel to structural building.

FEATURES

- PATENT PENDING
- P39 Corewall III Inserts are engineered for consistent performance and have proven to be one of the most advanced, adjustable inserts available on the market today.
- The design has been improved to create a higher load capacity and greater ease to install the product which significantly reduces erection costs
- The P39 insert uses heavy duty electro galvanized 3/4"-10 NC threaded nut to provide fast, efficient and reliable connections
- Stainless steel nut is available on special order
- The P39 Corewall Inserts are made from an engineered grade of polymer material that can withstand temperatures from 0°F to 140°F.
- Minimum edge distance, without the use of additional reinforcing steel is 12"

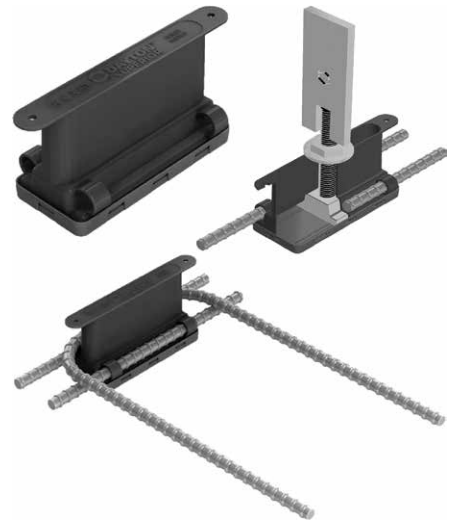

Technical Information

Product Code	Size	Condition	Horizontal Reinforcing	f _c '=5,000 psi	
				Ultimate Tension	Ultimate Shear
145643	2.5" x 6"	12" Away From the Edge	None	10,700	10,050
145643	2.5" x 6"		#3 x 9" Long	11,200	15,100
145643	2.5" x 6"		#4 x 12" Long	14,500	15,100
145644	3.5" x 6"		None	16,850	14,650
145644	3.5" x 6"		#3 x 9" Long	21,300	28,650
145644	3.5" x 6"		#4 x 12" Long	32,550	32,250
145645	4.5" x 6"		None	27,800	39,100
145645	4.5" x 6"		#3 x 9" Long	31,100	46,150
145645	4.5" x 6"		#4 x 12" Long	31,700	46,350
145643	2.5" x 6"		Edge	U-Shaped Bar	8,400
145644	3.5" x 6"	Edge	U-Shaped Bar	12,750	8,300
145645	4.5" x 6"	Edge	U-Shaped Bar	16,800	8,300
145643	2.5" x 6"	Corner	U-Shaped Bar	8,400	7,440
145644	3.5" x 6"	Corner	U-Shaped Bar	12,400	6,150
145645	4.5" x 6"	Corner	U-Shaped Bar	13,800	6,150

Load Capacity of P34L Strap Anchor

Eccentricity	Ult. Shear Load (lbs)	Ult. Tension Load (lbs)
1"	21,800	39,550
1.5"	21,700	
2"	20,100	
2.5"	18,100	
3"	15,300	

Edge / Corner Details

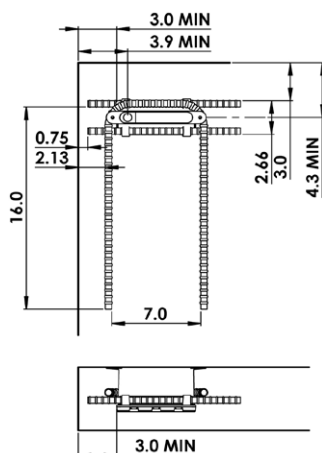

P39 Corewall Generation III Insert Ordering Information

Product Code	Depth	Length	Nut Adjustment	Color	Weight (lbs)
145643	2.5"	6"	4.5"	White	0.415
145644	3.5"	6"	4.5"	Red	0.447
145645	4.5"	6"	4.5"	Black	0.476

Miscellaneous Connection Inserts

Corewall Insert Installation Procedure

1. P39 Corewall Inserts can be used in three different ways:
 - a. Without any additional rebar
 - b. With additional horizontal bars (#3x9" or #4x12" long) for increased load capacity
 - c. With additional bent bars if inserts are installed close to panel edge or corners

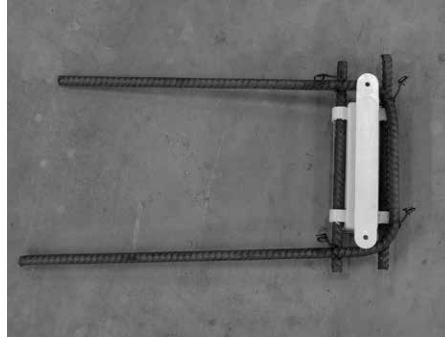

2. There are 3 ways to install P39 Corewall Inserts into concrete panels:
 - a. Inserts can be installed by nailing them to the wood that runs across the top of the panels
 - b. Inserts can be installed upside down by gluing them down to the steel forms
 - c. Inserts can be mucked-in after concrete is poured
3. After installing the required inserts, bar supports, rebar and lifting inserts, place and screed the concrete to the specified thickness.
4. At the jobsite, open up the insert's lid to get access to the steel nuts inside.



5. Attach the threaded rod, or a strap anchor, into the corewall steel T-nut.

Note: it is recommended that jam nut and washer are always used with both P34L Strap Anchors and threaded rods to resist compression forces.



6. On the other end, the strap anchor will be welded to the steel structure

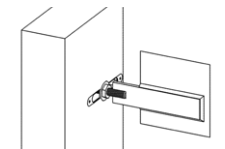

7. Or, the threaded rod will be bolted to the steel structure

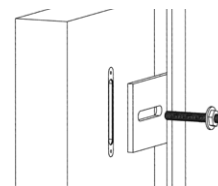

P12D Dur-O-Web® Shear Reinforcement

The Dayton Superior P12D Dur-O-Web is a prefabricated structural web reinforcement assembly that has been developed to replace conventional U-shaped and closed stirrups. The vertical steel wires provide reinforcement for the applied shear stresses. The double, horizontal side wires at the top and bottom of the assembly develop the required anchorage for the vertical wire reinforcement. The design of Dur-O-Web allows the spacing and size of both the vertical and horizontal wires to vary to meet your design requirements.

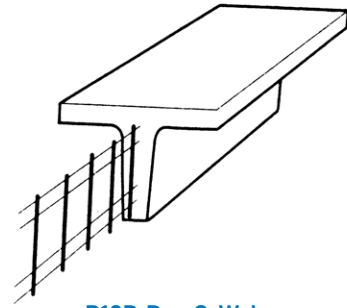

P12D Dur-O-Web Shear Reinforcement

Availability

Dayton Superior Dur-O-Web is shipped in bundles containing 500 ft. (50 pcs. of 10'-0" long units). Lengths other than 10'-0" can be supplied on special order. The standard finish is bright basic. Galvanized wire, hot dipped galvanized and epoxy coated finishes are also available on special order.

While Dur-O-Web is normally supplied with uniform spacing of vertical wires, variable spacing is available.

Benefits

- Ideal shear reinforcement for prestressed/precast concrete double tees, other precast elements having narrow webs, or where space is limited
- Wide variety of wire sizes and spacings
- Ready to use
- Reduces costs by eliminating the cutting and bending of standard rebars or mesh
- Easy to place
- Available in standard 10'-0" lengths
- Serves as a mesh support in double tee flanges
- The ability to vary wire diameters and spacing guarantees the most economical solution to your reinforcement requirements

Approvals

The use of Dayton Superior Dur-O-Web Shear Reinforcement to replace open and closed stirrups is allowed by American Concrete Institute (ACI-318) Standard Building Code Requirements for Concrete Structures, and Canadian Standards Association Standard CAN3A23.3 Design of Concrete Structures for Buildings.

Using the Selection Table

The P12D Dur-O-Web selection table, shown below, shows the diameter and area of the vertical shear reinforcement wires that are available. It also lists the minimum size horizontal anchor wire that ASTM standards require. In addition, the area of shear reinforcement per foot is shown for the various spacing of the vertical shear reinforcement selected.

Example:

A required shear steel area of 0.100 sq. in. per foot can be provided by using 1 gauge vertical wires spaced at 7-1/2" centers with 7 gauge longitudinal side wires. This example would provide 0.101 sq. in. of steel reinforcement per foot. Another solution would be the use of 5 gauge vertical wires spaced at 4" centers with 10 gauge longitudinal side wires. This combination would provide 0.102 sq. in. of reinforcement per foot.

P12D Dur-O-Web Selection Table

Wire Size	Wire Gauge	Wire Dia.	Steel Area (sq in)	Weight lb / ft	Min. Side Wire Gauge	Area of Steel (sq. in.) per Lineal Foot at Indicated Main Shear Reinforcement Spacing											
						2"	3"	4"	5"	6"	7"	7-1/2"	8"	9"	10"	11"	12"
W-7.4	0	0.306"	0.074	0.251	6	0.444	0.296	0.222	0.178	0.148	0.127	0.118	0.111	0.099	0.089	0.081	0.074
W-6.3	1	0.283"	0.063	0.214	7	0.378	0.252	0.189	0.151	0.128	0.108	0.101	0.095	0.084	0.076	0.069	0.063
W-5.4	2	0.263"	0.054"	0.184	8	0.324	0.216	0.162	0.130	0.108	0.093	0.086	0.081	0.072	0.065	0.059	0.054
W-4.9	1/4"	0.250"	0.049"	0.167	9	0.294	0.196	0.147	0.118	0.098	0.084	0.078	0.074	0.065	0.059	0.053	0.049
W-4.7	3	0.244"	0.047"	0.158	9	0.282	0.188	0.141	0.113	0.094	0.081	0.075	0.071	0.063	0.056	0.051	0.047
W-4.0	4	0.225"	0.040"	0.135	10	0.240	0.160	0.120	0.096	0.080	0.069	0.064	0.060	0.053	0.048	0.044	0.040
W-3.4	5	0.207"	0.034"	0.114	10	0.202	0.136	0.102	0.082	0.068	0.058	0.054	0.051	0.045	0.041	0.037	0.034
W-2.9	6	0.192"	0.029"	0.098	10	0.174	0.116	0.087	0.070	0.058	0.050	0.046	0.044	0.039	0.035	0.032	0.029
W-2.5	7	0.177"	0.025"	0.084	10	0.150	0.100	0.075	0.060	0.050	0.043	0.040	0.038	0.033	0.030	0.027	0.025
W-2.1	8	0.162"	0.021"	0.070	10	0.126	0.084	0.062	0.050	0.042	0.036	0.034	0.032	0.028	0.025	0.023	0.021
W-1.7	9	0.148"	0.017"	0.059	10	0.102	0.068	0.051	0.041	0.034	0.029	0.027	0.026	0.023	0.020	0.019	0.017
W-1.4	10	0.135"	0.014"	0.049	10	0.084	0.056	0.042	0.034	0.028	0.024	0.022	0.021	0.019	0.017	0.015	0.014

P12D Dur-O-Web® Shear Reinforcement

Material Specifications

Dayton Superior Dur-O-Web is manufactured with smooth, round vertical steel wires and smooth, round horizontal side wires. All materials and products conform to the latest edition of one or more of the following ASTM specifications:

- A-82 Standard Specification for Steel Wire, Plain, for Concrete Reinforcement
- A-185 Standard Specification for Steel Welded Wire Fabric, Plain, for Concrete Reinforcement

Weight Calculation

The sample calculation, below, shows how to calculate the approximate weight of steel used in different Dur-O-Web assemblies:

P12D Dur-O-Web

Vertical wires: 1 gauge at 6" centers
 Horizontal side wires: 4 pcs. of 7 gauge
 Height: 22" overall
 Length: 10'-0"

$$\begin{aligned} \text{Vertical wires} &= 22'' \div 12'' \text{ per ft.} \times 12'' \text{ per ft.} \div 6'' \text{ centers} \times .214 \text{ lb. per ft.} \times 10 \text{ ft.} &= 7.87 \text{ lb.} \\ \text{Side Wires} &= 4 \text{ pcs.} \times 0.084 \text{ lb. per ft.} \times 10 \text{ ft.} &= 3.36 \text{ lb.} \\ \text{Total weight per 10 ft. unit} & &= 11.23 \text{ lb.} \end{aligned}$$

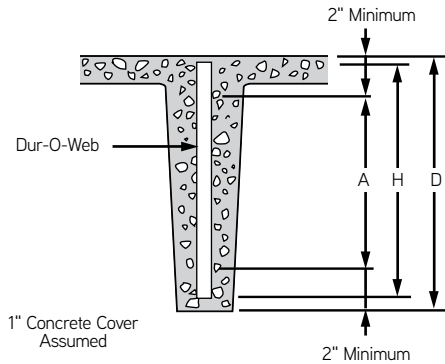

Double Tee

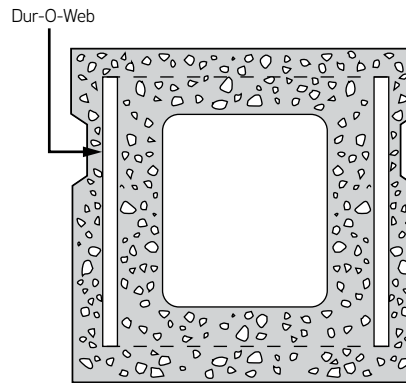

Bridge Beams

Depth of Concrete Member "D"	Dimension "A"	P12D Dur-O-Web Overall Height "H"
8'	2'	6'
10'	4'	8'
12'	6'	10'
14'	8'	12'
16'	10'	14'
18'	12'	16'
20'	14'	18'
22'	16'	20'
24'	18'	22'
32'	26'	30'

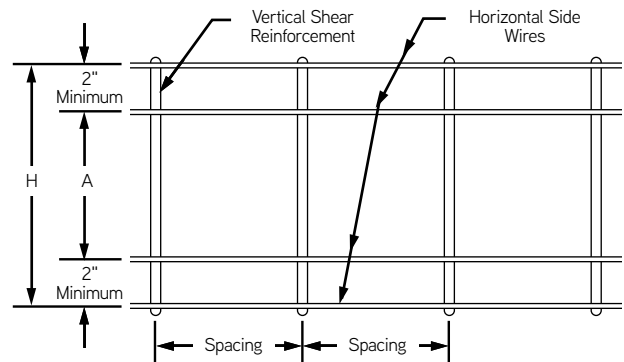

Miscellaneous Connection Inserts

To Order:

Specify: (1) quantity, (2) overall height "H," (3) name, (4) gauge and spacing of vertical wires, (5) gauge of side wires, (6) overall length (7) finish.

Example:

275, 22" high, P12D Dur-O-Web, 1 gauge verticals at 6" centers, 7 gauge side wires x 10 ft. long, bright basic finish.

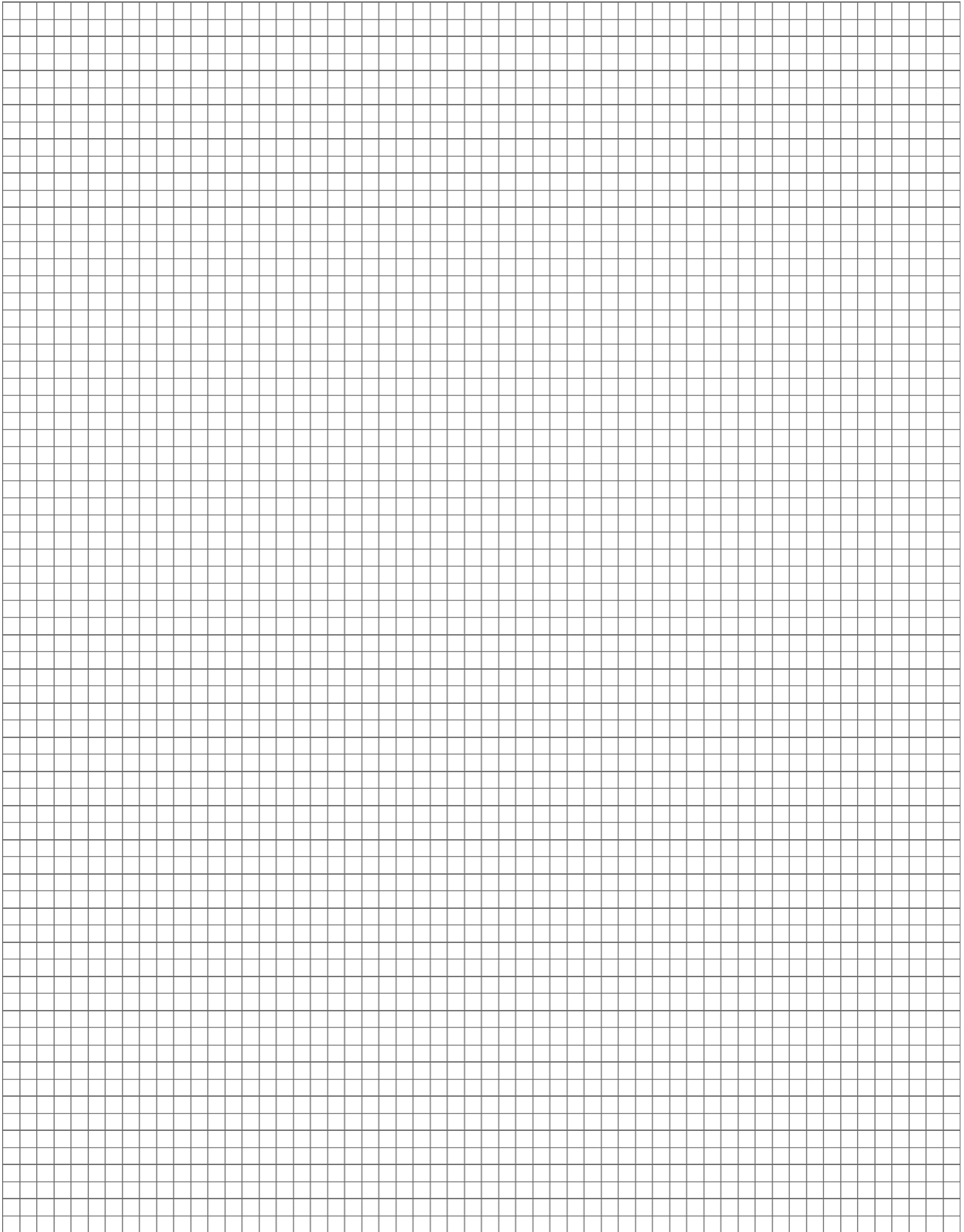

P24 Delta Tie

The Dayton Superior P24 Delta Tie is a unique insulated precast concrete panel connector. It allows the precaster to fabricate a highly energy-efficient, insulated precast concrete sandwich wall panel using the insulating foam of his choice.

This versatile connector allows the foam insulation to be placed from panel edge to panel edge, eliminating thermal bridges and costly energy loss. The foam insulation is sandwiched between two concrete wythes, or layers, to form a long-lasting, energy-efficient precast concrete sandwich wall panel. The three wythes are tied together using P24 Delta Ties. Spacing of the Delta Ties varies, based on the panel's required composite moment capacity.

The Delta Tie is produced using an engineered composite matrix. It consists of a geometrically configured, two-dimensional truss manufactured from continuous wound fiberglass embedded in an alkali resistant resin. The design of the Delta Tie produces a connector of remarkable strength and durability.

The non-metallic, non-corrosive design of the Delta Tie eliminates any thermal transfer through the panel, increasing the insulating efficiency of the panel.

Advantages

- Increased load bearing.
- Stiffer insulated panels, easier to handle.
- Design flexibility.
- Material, labor and transportation cost reduction.
- Quick and easy installation.
- Applicable to all brands of foam panel insulation.

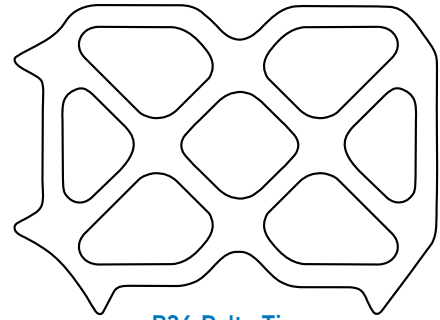

P24 Delta Tie
U.S. Patent #6761007



P24 Delta Tie

The standard Delta Tie dimensions are shown in the accompanying detail.

The connector is designed so that it can be oriented in the panel either on end or side, depending on the thickness of the panel. For example, the 5" x 7" size can be used on its side in a six-inch panel or on end for thicker panels. The Delta Tie can be used with any rigid insulation from 1" to 4" thick. This versatile, dual-use feature adds to the Delta Tie's effective application compatibility and, at the same time, reduces inventory and storage requirements.

In individual connector specimen and full size panel tests the Delta Tie has exhibited excellent loading behavior and load capacities.

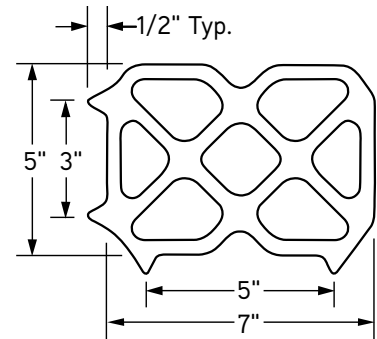

Increased Load Bearing

Tests have verified the excellent tension and shear strength characteristics of the Delta Tie insulated panel connector.

Stiffer Insulated Concrete Panels

The inherent capabilities of the truss design greatly increase the stiffness of the panel. The added stiffness makes the panel easier to lift, handle, store and/or transport.

Design Flexibility

Due to the composite action gained by using the Delta Tie, panels may be cast in longer lengths or with thinner concrete wythes.

Cost Savings

The Delta Tie design provides a fast and easy installation to save labor. It produces stiffer panels to lessen handling, storage and transportation concerns. The connector's design flexibility allows the cost saving attributes to be designed into the panel. Delta Tie connectors are purchased as a separate item, allowing the precaster to provide the foam insulation of his choice.

Quick and Easy Installation

The two-dimensional design of the Delta Tie lends itself to easy installation. No drilling or special tools required. Simply use the foam as a straight-edge template to quickly place the connectors.

Applicable to All Brands of Foam Panel Insulation

The Delta Tie is not sold as part of a package. It is sold separately and can be used with any brand of foam insulation supplied by the precaster.

The many Delta Tie advantages open up a wide area of possibilities for the precaster/designer/producer to improve production, efficiency and costs at his precasting operation.

The P24 Delta Tie has the following ultimate capacities:

- 3,220 lbs. in shear.
- 3,100 lbs. in tension.

Maximum recommended spacing is 8 square feet of panel per panel connector. For spacing in excess of 8 square feet of panel per connector, contact a Dayton Superior Technical Assistance.

- NFPA 285
- ASTM E-119
- Five Test Approved

To Order:

Specify: (1) quantity, (2) name.

Example:

500, P24 Delta Ties.

P24 Delta Tie Design Table

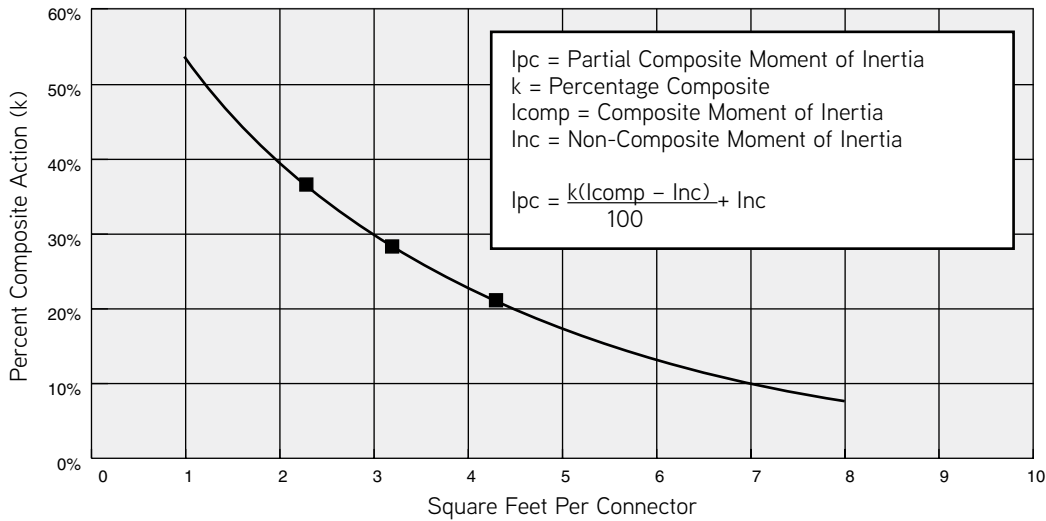

Notes:

When composite action is not required, maximum connector spacing for a 3-2-3 panel is 8 sq. ft. per connector.

Test reports are available on request.

Typical Delta Tie Placement

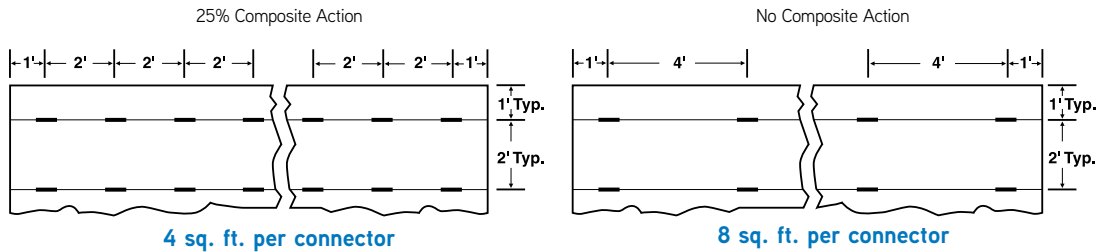

Composite Moment Capacity

For any given sandwich panel, the shear and moment diagrams define the required panel stiffness. The panel stiffness may be altered, as necessary, pending panel parameters, by adjusting the tie distribution as a function of the internal shear and moment forces. The two examples, below, illustrate the required stiffness (percent composite action) necessary to develop the shear and moment forces.

1. A panel measuring 37'-0" long by 6'-0" wide, with a 3-2-3 wythe pattern, must have a 5% composite action to achieve a flat lift with 4x2 rigging.
2. A 2-2-2 panel of same size requires a 10% composite action for the same rigging.

In order to employ the least amount of concrete to save weight, the percent of composite action must increase. A small upward adjustment can be realized by a minimal addition of connectors strategically placed at the zones of maximum shear.

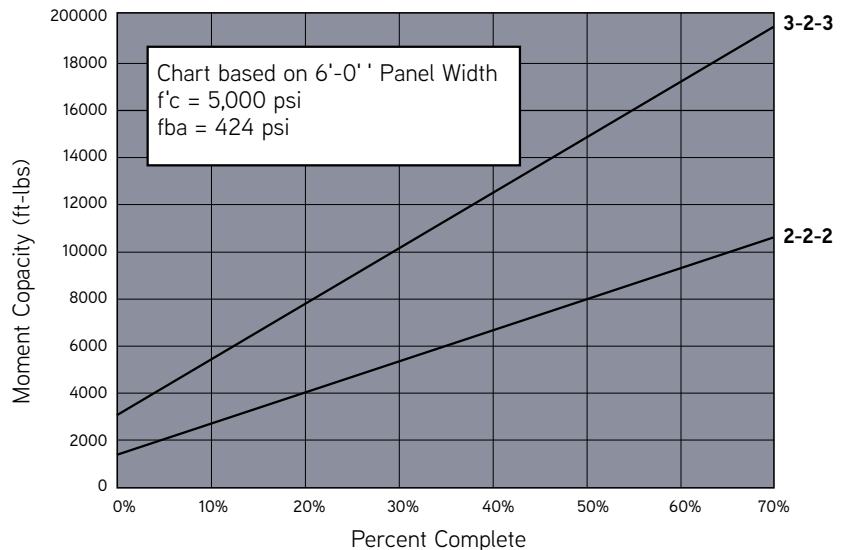

P24 Delta Tie Insulated Panel Installation Sequence



1. Construct form, place reinforcing mesh, lifting inserts, etc. Place and screed the concrete for the bottom wythe.



2. While the bottom wythe concrete is still pliable, lay the first course of insulating foam flush against the form. Typically, the first course of foam will be 12' running the length of the panel. Utilize the edge of the foam as a template and push each Delta Tie down into the bottom wythe.



3. Continue to place the connectors in their proper positions along the first course of insulation.

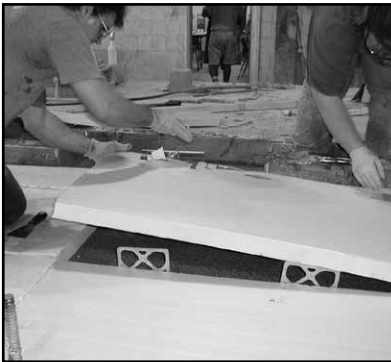

4. Add the remaining courses of insulation and connectors.*



5. When all of the foam sections and connectors have been placed, the top concrete wythe is poured and screeded as necessary.



6. After proper concrete set, the panel may be removed from the form and the process repeated.

* Foam-backed tape is available for sealing the insulation joints, if necessary.

P24XL Delta Tie

The Dayton Superior P24XL Delta Tie is a two-dimensional truss of structurally non-conductive, non-metallic, non-corrosive fiber composite used as a wythe connector for concrete sandwich panel construction. The P24XL Delta Tie is just like the widely used P24, but it is designed for applications with 5" to 8" of insulation.

The size is 9" x 11" x 5/32" with 1/2" tabs and v-notch installation aides.

Ties are normally installed in the seams between sheets of insulation, or the insulation can be cut and the ties positioned through the insulation. For insulation with an integral vapor barrier, it is important to insure that it is also cut so as to not interfere with the concrete tie embedment. Ties must be installed a maximum of 12" from any edge or opening. A typical spacing pattern provides one tie for every 2-8 square feet of panel surface area. The preferred tie orientation is parallel to the height of the panel.

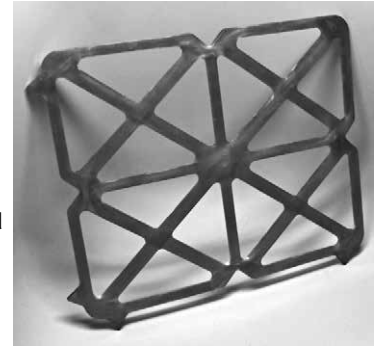

Specifications

Composite Modulus: 8,370,000 psi

Composite Tensile Strength: 167, 400 psi

Poisson's Ratio: 0.26

Density: 110 lbs/cu ft

Alkali Resistance: Made from continuous wound alkali resistant glass fibers in an alkali resistant epoxy bisphenol A vinyl ester resin. The resin is rated for continuous alkali exposure at up to 180°F, and is also UV resistant. The resin's glass transition temperature is 285°F, and its melting point is 650°F.

Glass Content: 1.45 micron, 2.4 g/m, 14GPa tensile strength, continuous roving fibers at 77% by weight. The continuous operating temperature of the 19% zirconium glass fiber is 900°F.

Thermal Conductivity: 0.1447 BTU/hr F ft (0.25 W/m•C) where Insulation Board is 0.014, and Concrete is 1.2414. The Delta Tie R-Value is 0.576 sq ft F hr/BTU per inch of thickness.

CTE: Is matched to concrete at 0.0000055 in/in/F.

Delta Tie Type	Insulation Thickness (inches)	Tension Capacity * (lbs)	Shear Capacity * (lbs)
P24 (5"x7")	1-4	3100	3400
P24XL (9"x11")	1-5	5800	3700
P24XL (9"x11")	6	3400	3075
P24XL (9"x11")	7	4000	2800
P24XL (9"x11")	8	3200	1650

* Ultimate Strength per Tie. Factor of Safety is variable based on the panel configuration.

P12G Welded Wire Girders

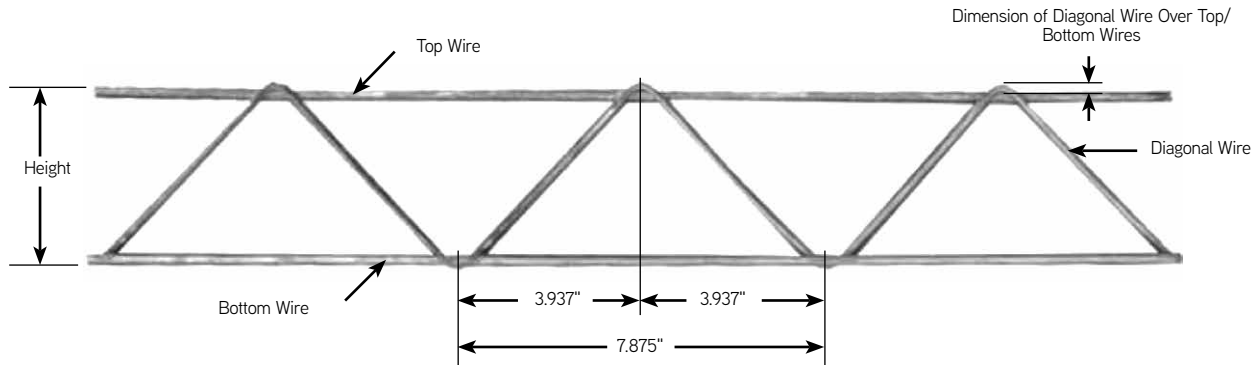

The growth of energy-efficient construction has guided the precast concrete industry to design and produce cost-effective and time-saving wall panel techniques.

Federal and state energy regulations have driven the popularity of “sandwich panel” walls which feature a layer of insulation “sandwiched” between layers of concrete.

Dayton Superior offers the P12G Welded Wire Girder as one method to meet the need for a unique shear connector adequate to properly transfer or distribute loads between panels.

Dayton Superior girder prevents undesirable energy transfer by eliminating solid concrete sections in the entire panel — no high stress points, no major thermal areas, no cold spots, no wet areas — and a more efficient and cost-effective insulated wall panel.

Most importantly, Welded Wire Girder not only connects the concrete widths through the insulation material, but has the resiliency to expand and contract with the independent thermal-induced movements of the outer width.

INSTALLATION

1. Install bottom width mesh and place single girder in form, tie to mesh or pre-stressed cables.
2. Pour bottom width concrete, raise or rotate single girder to a vertical position such that 2/3 of the girder is standing out of concrete.
3. Install insulation board in strips between the girder and walk along the insulation board, pressing the insulation board in and around the girder diagonal wires. If any gaps or spaces occur, tape or caulk gaps to prevent concrete from bridging between bottom and top widths.
4. Install top width mesh and tie to girder, or to pre-stressed cables for support and proper positioning in center of top width. Place remaining concrete to form top width.

Top Wire:

- Minimum: 4GA 0.225" diameter
- Maximum: OGA 0.306" diameter

Bottom Wire:

- Minimum: 4GA 0.225" diameter
- Maximum: OGA 0.306" diameter

Diagonal Wire:

- Minimum: 6GA 0.192" diameter
- Maximum: 3GA 0.243" diameter

Height:

- 3" to 8.5" in increments of 1/2" (flush style)
- 3" to 9" in increments of 1/2" (set back style)

Length:

- 3'-11" to 34'-5"

Finish:

- Plain or mill galvanized

Pricing:

- Contact Customer Service. All product made-to-order.

How to Order:

- Quantity, name, height, length, wire diameters (top/bottom/diagonal), dimensions of diagonal over top/bottom wire, finish (top/bottom/diagonal).

Manufacturing Location:

- Kankakee, Illinois

P9 Precast Sandwich Panel Tie

The Dayton Superior P9 Precast Sandwich Panel Tie is manufactured to specifications from 3 gauge (0.243" diameter) stainless steel or galvanized wire.

Place the connectors at the edge of the foam insulation so the body of the tie is at the joint line between two pieces of foam. Next, the ends of the tie are rotated 90° so they bear against the foam insulation. Spacing of the panel connectors are per job requirements.

After the panel ties have been attached to the foam insulation, they are placed on the freshly placed bottom wythe of concrete. Later, the top wythe of concrete is placed.

The chart, below, lists the sizes of panel ties produced in the cast for various precasters. Other sizes can be produced on special order.

P9 Precast Sandwich Panel Tie

A	3"	4"	4"	5"	6"	7"	8"
B	1"	1"	2"	3"	3"	3"	3"

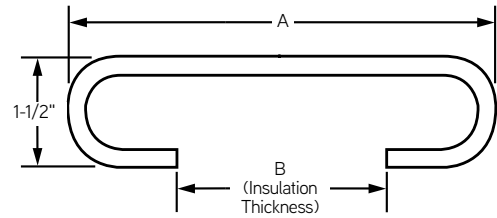

P9 Precast Sandwich Panel Tie

To Order:

Specify: (1) quantity, (2) name, (3) A and B dimensions (4) finish.

Example:

200, P9 Precast Sandwich Panel Ties, A=4", B=2", stainless steel.

P37 "M" Anchor Shear Connector

The Dayton Superior P37 M Anchor Shear Connector is available in various sizes. Fabricated from 1/4" diameter galvanized wire, these connectors are designed for use as a shear connector in precast concrete sandwich panels. For proper use, place the connectors at the following maximum spacing:

- 18" on center maximum across the width of the panel.
- 24" on center maximum along the length of the panel.
- Place additional connectors around the panel's lift points.

Edge distance requirements are 6" minimum center line to the panel end and 4" minimum center line to the panel's edge. Place connectors parallel to the length of the panel.

Minimum embedment at the open end is 2"

To Order:

Specify: (1) quantity, (2) name, (3) style.

Example:

1200, P37 "M" Anchor Shear Connectors, No. CP107.

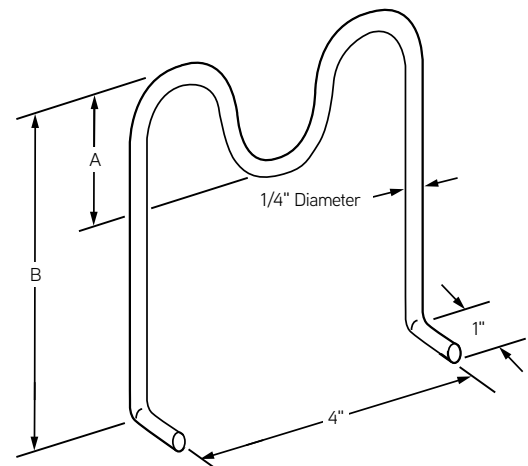

P37 "M" Anchor Shear Connector

P37 "M" Anchor Shear Connectors

Style	A	B	Maximum Insulation Thickness
CP106	2"	6"	2"
CP107	2"	7"	3"
CP206	1-1/2"	6"	2-1/2"
CP207	1-1/2"	7"	3-1/2"

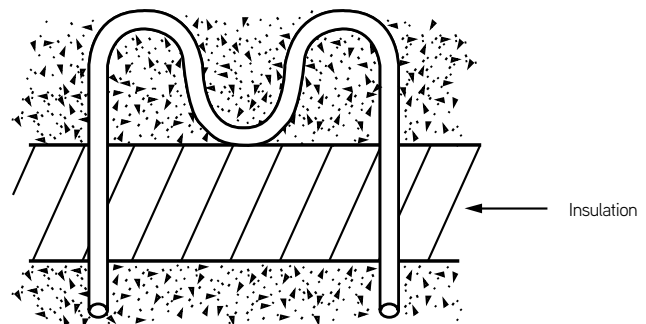

Typical Installation

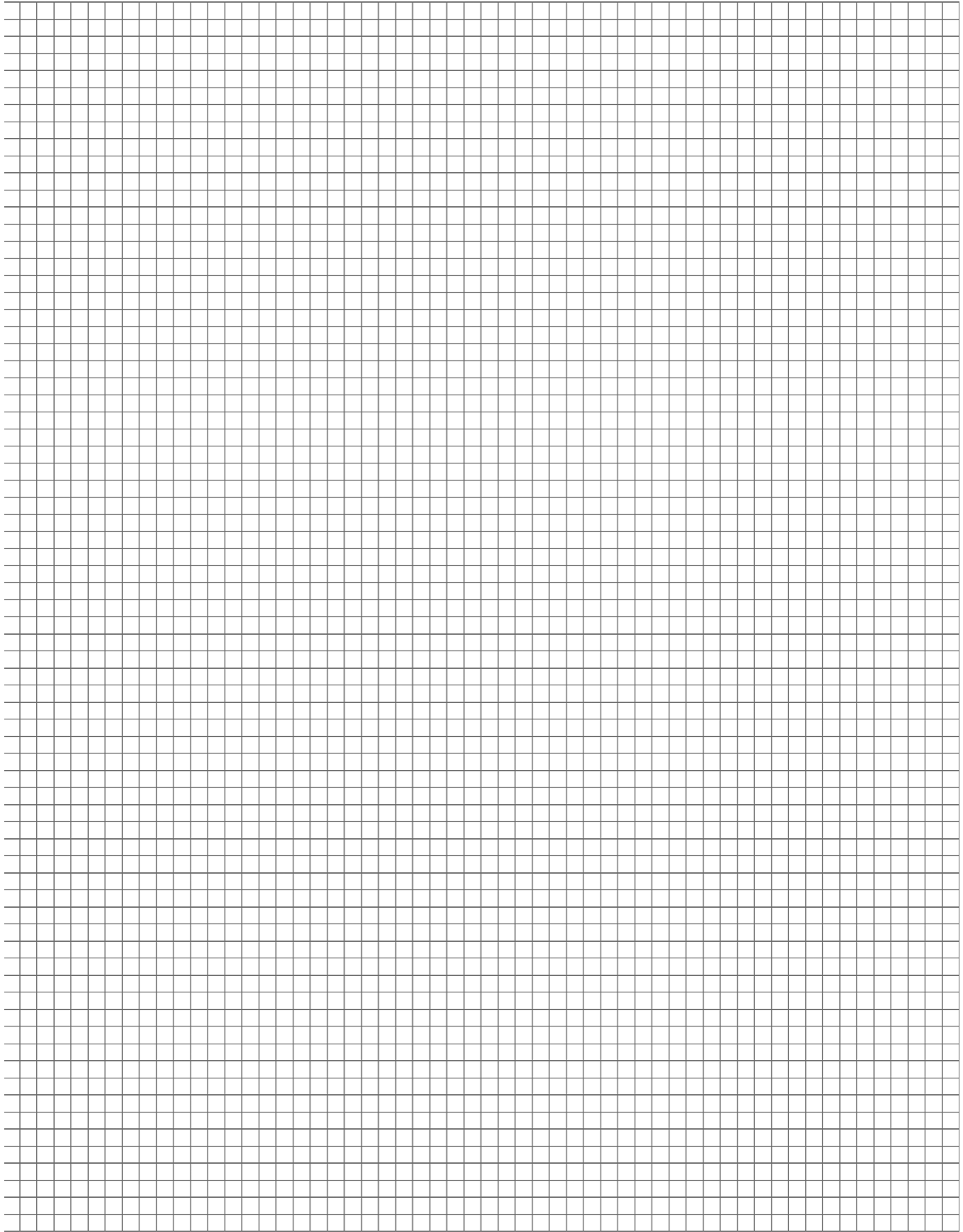

Prestress Strand Restraining Devices

By deflecting some of the prestressing strands, in a precast prestressed concrete beam, a more favorable distribution of stresses within the concrete beam is obtained. When using deflected strands, the eccentricity of the prestressing force is reduced in the area of decreasing dead load moment. By reducing the tensile stresses in the concrete, the load that can be applied to the beam can be increased by an amount equal to the weight of the beam itself.

The benefits obtainable through strand deflection are such that many precast prestressed concrete plants are designed so that the prestress strands can be deflected. When using depressed strands, it is necessary that strand restraining devices be provided at the points within the concrete beam where the strand deflections occur.

Working closely with many prestressed concrete producers, Dayton Superior has developed a complete line of strand restraining devices. Since 1958, Dayton Superior strand deflection devices have been recognized and accepted as the industry standard. All units are manufactured on a production basis and are produced with positive (no welding) mechanical connections.

These units maintain a clear distance of 1-1/2" from bottom of the strand restraining device to beam bottom yet still hold a 2" dimension from the centerline of the strand to the beam bottom.

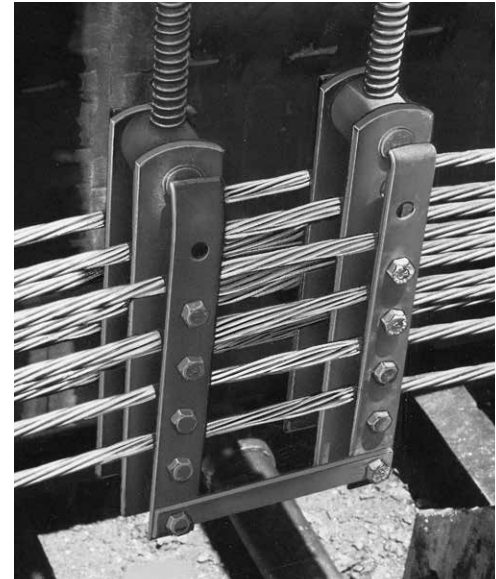

View of Strand Restraining Device
"Free-turning" rollers contribute additional safety, reducing frictional resistance.

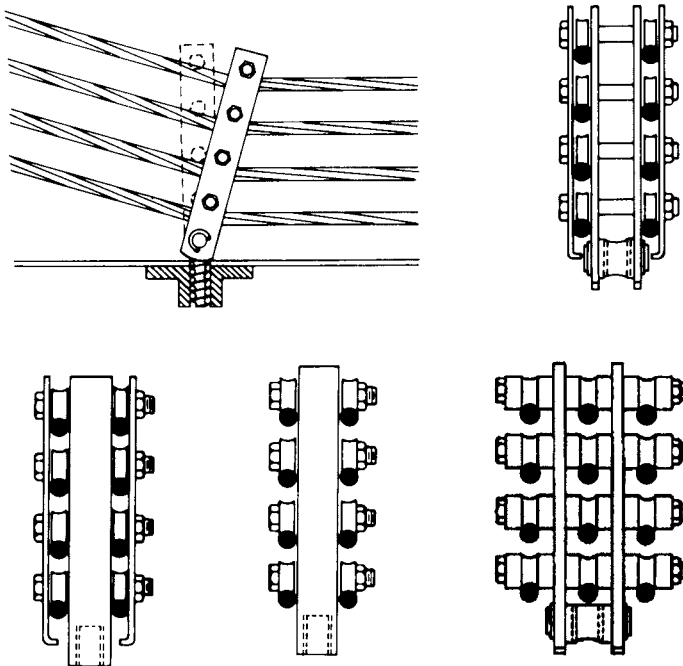

Large variety of styles available to fit your needs



Illustration of swivel action as strand restraining device responds to strand tensioning.

Note: For more information on the complete prestressing system or individual components, request a copy of the Prestress Strand Deflection Device Handbook

T14 Tilt-Up Wall Braces

The T14 Tilt-Up Wall Braces are all steel, heavy duty wall braces designed to quickly and easily align and brace tilt-up wall panels. Rough adjustment of the T14 braces is easily accomplished by telescoping the pipes to the nearest incremental hole.

Final adjustment is then achieved by simply turning the brace. Dayton Superior wall braces are available in numerous sizes to provide a continuous range of tilt-up panel heights of fifty feet or more. Refer to the table below for additional information.

T14 Tilt-Up Pipe Brace

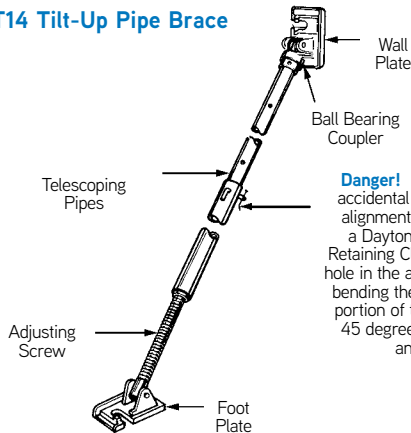

T14 Tilt-Up Jumbo Brace

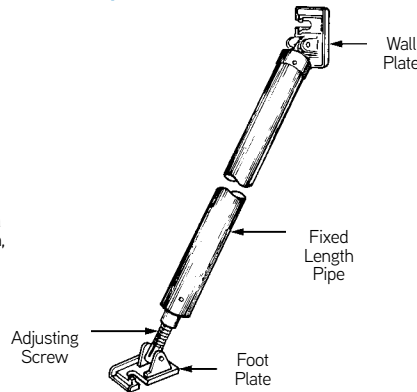

Danger! To prevent accidental removal of alignment pin, insert a Dayton Superior Retaining Clip through a hole in the alignment pin, bending the protruding portion of the nail to a 45 degree minimum angle

To Order:

Specify: (1) quantity, (2) name, (3) model.

Example:

200, T14 Tilt-Up Wall Braces. Model B8.

T14 Pipe Brace Selection Chart

Type	New Name	Description	Minimum and Maximum Brace Length	Brace Weight (Lbs)
B1A	BA0814R	Short Pipe Brace	8'-0" to 14'-0"	87
B4	BA1423R	Heavy Duty Regular Pipe Brace	14'-6" to 23'-6"	130
B5	BA2239R	Heavy Duty Long Pipe Brace	22'-6" to 39'-0"	208
B7	B17R13R	Short Jumbo Brace	17'-0" Fixed Length	107
B8	B22R9R	Jumbo Brace	22'-0" Fixed Length	130
B9	B22+5R7R	Jumbo Brace with 5'-0" Extension	27'-0" Fixed Length	172
B10	B22+10R5R	Jumbo Brace with 10'-0" Extension	32'-0" Fixed Length	193
B11	BA2540R	Tru-Iltt Brace	25'-6" to 40'-0"	505
B12A	B32R13R	Jumbo 5-1/2"	32'-0" Fixed Length	245
B13**	B27R18R	Jumbo 5-1/2"	27'-0" Fixed Length	237
B14*	B32+10R7R	B12 Jumbo Brace, 10'-0" Extension	42'-0" Fixed Length	382
B15*	B32+20R5R	B12 Jumbo Brace, 20'-0" Extension	52'-0" Fixed Length	410
B16	BA32+5R12R	B12 Jumbo Brace, 5'-0" Extension	37'-0" Fixed Length	360
B17A	B42R19R	Super Brace	42'-0" Fixed Length	613
B18	B52R19R	Super Brace	52'-0" Fixed Length	984

Notes: * Field assembly is required for B14 and B15 braces.

Fixed length allows for +/-9" of adjustment except B17A brace has +/-7.5" of adjustment and B18 Brace has 11.75" of adjustment on each end.

Pipe Extensions: T15 for the B8 model and T20 for the B12 model

Note: ** B13 is Made to Order brace

T15 Pipe Brace Extensions

The Dayton Superior Pipe Brace Extensions are available for the B8 and B12 pipe brace models. The T15 extension for the B8 model extends the brace five feet or ten foot increments. The T20 extension for the B12A model extends the brace in five or 10 foot increments.

To Order:

Specify: (1) quantity, (2) name, (3) model.

Example:

40, T15 Pipe Brace Extension, 5' extension for B8 braces.

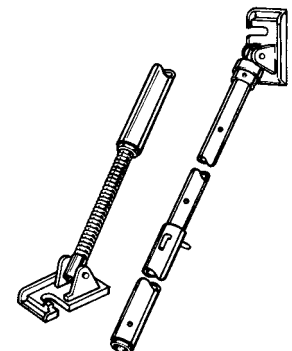

Brace Length and Safe Working Loads

How to Calculate Brace Length

- D** = Elevation — top of panel above floor slab (not necessarily same as panel height).
- W** = Wall insert dimension = $2/3 D$
- F** = Floor insert dimension = $3/4 W$
- B** = Brace length = $5/4 W$

The brace dimension (W) must be a minimum of 5% of the panel's overall height above the panel's geometric and mass center of gravity. After the locations of the braces are determined, the panel structure should be checked to verify that it is strong enough to resist temporary wind loads.

Brace locations other than those shown may drastically increase brace loads. Brace angles over 60° from the horizontal result in poor mechanical advantage and excessive vertical kick, while brace angles under 50° decrease brace buckling strength due to greater length and excessive sag.

Danger! Bracing must be installed at $90^\circ \pm 5^\circ$ to plane of panel or brace safe working load will be greatly reduced.

The following is a quick "Rule of Thumb" to use in determining if a brace is installed at $90^\circ \pm 5^\circ$ to the panel: The brace may be skewed left or right 1 inch for every 1 foot that the brace anchor is located away from the wall. For example: If your dimension "F" is 15 ft, then your braces may be skewed 15" left or right and still stay within the required 5° tolerance. See panel layout sheets for proper "F" dimension.

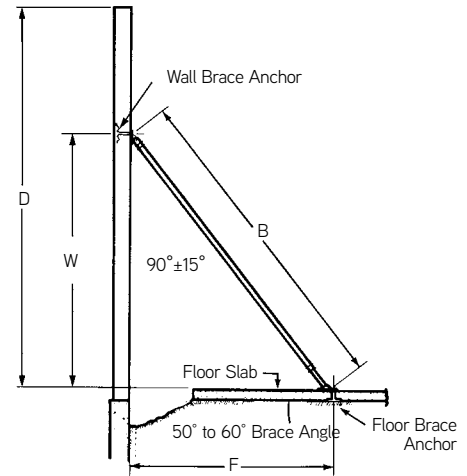

Note: End braces to ground and/or crossbraces must be installed every 100 ft. to prevent lateral movement of braces and to provide total brace stability.

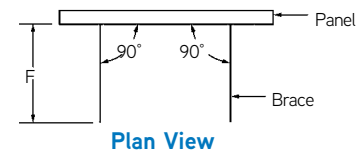

Brace Length and Ultimate Loads

B1A Short Pipe Brace				
D	W	F	B	Ultimate Load
9'-0"	6'-0"	4'-6"	7'-6"	9,750 lbs
9'-6"	6'-5"	4'-8"	7'-11"	9,750 lbs
10'-0"	6'-8"	5'-0"	8'-4"	9,750 lbs
10'-6"	7'-0"	5'-3"	8'-9"	9,750 lbs
12'-0"	8'-0"	6'-0"	10'-0"	9,750 lbs
13'-0"	8'-9"	6'-3"	10'-9"	9,675 lbs
14'-0"	9'-6"	6'-9"	11'-8"	7,838 lbs
15'-0"	10'-0"	7'-4"	12'-5"	6,675 lbs
16'-0"	10'-9"	7'-9"	13'-3"	5,625 lbs

B4 Heavy Duty Regular Pipe Brace				
D	W	F	B	Ultimate Load
18'-0"	12'-0"	9'-0"	15'-0"	9,750 lbs
19'-0"	12'-8"	9'-6"	15'-10"	9,750 lbs
20'-0"	13'-4"	10'-0"	16'-8"	9,750 lbs
21'-0"	14'-0"	10'-6"	17'-6"	8,888 lbs
22'-0"	14'-8"	11'-0"	18'-4"	7,200 lbs
23'-0"	15'-4"	11'-6"	19'-2"	5,888 lbs
24'-0"	16'-0"	12'-0"	20'-0"	5,363 lbs
25'-0"	16'-8"	12'-6"	20'-10"	4,463 lbs
26'-0"	17'-4"	13'-0"	21'-8"	3,750 lbs
27'-0"	18'-0"	13'-6"	22'-6"	3,413 lbs
28'-0"	18'-8"	14'-0"	23'-4"	2,525 lbs

B5 Heavy Duty Long Pipe Brace				
D	W	F	B	Ultimate Load
27'-0"	18'-0"	13'-6"	22'-6"	8,963 lbs
28'-0"	18'-8"	14'-0"	23'-4"	7,988 lbs
29'-0"	19'-4"	14'-6"	24'-2"	7,200 lbs
30'-0"	20'-0"	15'-0"	25'-0"	6,375 lbs
31'-0"	20'-8"	15'-6"	25'-10"	5,175 lbs
32'-0"	21'-4"	16'-0"	26'-8"	4,238 lbs
33'-0"	22'-0"	16'-6"	27'-6"	3,825 lbs
34'-0"	22'-8"	17'-0"	28'-4"	3,150 lbs
35'-0"	23'-4"	17'-6"	29'-2"	2,625 lbs
36'-0"	24'-0"	18'-0"	30'-0"	2,400 lbs
37'-0"	24'-8"	18'-6"	30'-10"	2,025 lbs

Jumbo Pipe Braces					
Type	D	W	F	B	Ultimate Load
B7	15'-0" to 24'-0"	13'-6"	10'-4"	17'-0"	13,050 lbs
B8	19'-0" to 31'-0"	17'-6"	13'-4"	22'-0"	9,750 lbs
B9	23'-0" to 39'-0"	21'-6"	16'-4"	27'-0"	7,200 lbs
B10	27'-0" to 46'-0"	25'-6"	19'-3"	32'-0"	5,400 lbs
B11	22'-0"	20'-5"	15'-4"	25'-6" Min.	13,500 lbs
B11	58'-0"	32'-0"	24'-0"	40'-0" Max.	13,500 lbs
B12	27'-0" to 46'-0"	25'-6"	19'-4"	32'-0"	13,500 lbs
B13	23'-0" to 39'-0"	21'-6"	16'-4"	27'-0"	18,000 lbs
B14	35'-0" to 60'-0"	33'-6"	25'-4"	42'-0"	7,800 lbs
B15	43'-0" to 60'-0"	41'-6"	31'-4"	52'-0"	5,700 lbs
B16	42'-0"	29'-6"	22'-4"	37'-0"	12,000 lbs
B17A	35'-0" to 60'-0"	33'-6"	25'-3"	42'-0"	19,000 lbs
B18	52'-0"	41'-6"	31'-4"	52'-0"	19,200 lbs

Note: Depending on panel thickness and height, a double mat of reinforcing steel may be required to resist the bending stresses of temporary wind loads.

Note: When calculating maximum brace spacing, always compare the selected brace load with the maximum brace load that can be safely carried by the brace anchor.

Brace Loading

Bracing recommendations are for the sole purpose of temporarily bracing fully erected concrete tilt-up panels during construction — against wind loads only. This temporary bracing design is based on the latest editions of The American Society of Civil Engineers (ASCE-7) Minimum Design Loads for Building and other Structures, ASCE-37 Design Loads of Structures During Construction, and the Tilt-Up Concrete Association Guideline for Temporary Wind Bracing to determine the wind loads that are applied to an erected tilt-up panel. The ASCE standards and the TCA guideline allow the basic wind speed, which is based on a 15% probability of three second gust wind speed in exceedence at thirty-three feet above ground level.

Brace anchors and main, knee, lateral and/or end braces are not designed or intended to sustain impact loads. Precautions must be taken to arrange the panel erection sequence so as to avoid the potential for impacting upright panels or portions of the bracing system. Bracing recommendations for other loads or forces that might be applied to the bracing system are beyond the scope of Dayton Superior. For bracing recommendations other than wind loads, the user should engage a design agency with capabilities of performing such a service.

Brace Removal

This bracing system is designed to temporarily support panels against wind loads until the building structure is complete and self supporting. The bracing system should never be disconnected or removed until the panels are secured by the permanent structural connections and all lateral load resisting systems are in place.

If the structural documents do not indicate when the temporary bracing system can be removed, the engineer of record should be consulted.

Safety Notes:

- Panel should be plumb with braces and knee braces installed before crane releases panel.
- Lateral bracing should be installed immediately upon the crane and crew clearing the braces and before the next panel is erected.
- Lateral bracing must be continuous, connected at each brace, and tied off with end braces at the end of each line.
- Panels require a minimum of two braces per panel.
- End braces to ground and/or cross braces must be installed every 100 ft. to prevent lateral movement of braces and to provide total brace stability.
- All members of the brace system must be in place and secured at the end of each day.
- Knee and lateral bracing must be located at mid-length of pipe brace.
- Knee brace must be firmly fixed at bottom end to prevent possible upward buckling of main brace.
- Do not erect panels or continue working during excessive windy or adverse weather conditions.
- All brace inserts should be a minimum of 12" from any panel edge, opening, control joint or construction joint.
- Panel bracing is designed to withstand specified wind loads until panels are connected to the structural system of the building. Do not remove any members of the bracing system until all structural connections are completed.
- Use only the brace type as noted on the Panel Layout Sheet. No substitute brace hardware shall be used and all braces must be positioned at the specified locations.
- For special bracing conditions that require deviation from the bracing dimensions shown on the Panel Layout Sheet contact Dayton Superior for recommendations.
- See Panel Layout Sheet for type of brace, number of braces per panel, as well as knee and lateral bracing requirements.
- Welding or bolting the tilt-up panels in place might preclude the use of braces.
- After winds of 35 mph or more have been experienced at the job site, the tilt-up contractor must check the tightness of the bolts that secure the wall and foot plates to the concrete. Re-tightening of these bolts to the proper torque will assure that the pipe braces are secure.
- The safe working load of the panel's bracing system may be drastically reduced if other types of brace anchors are used as part of this project's bracing system, other than specified brace anchors.

Warning! Failure to install knee, lateral and end braces (when required) will greatly reduce the safe working load of the specified brace and may allow panels to fall causing severe injury or death.

Brace Maintenance

During the construction process, braces may be exposed to adverse conditions that could damage or render them unusable. Braces should be inspected for proper operation, damage and wear after each use.

This inspection is typically performed by a Dayton Superior Certified Precast Dealer when the braces are returned. However, when braces are transferred from one job to another without being returned to Dayton Superior or its dealer for maintenance, the user must inspect all braces prior to their being reused.

This inspection should check for missing parts, parts, wear, dings, kinks, straightness, indication of any application of heat and/or other damage.

Any brace that shows signs of wear, has missing parts, damage, or is questionable should be set aside and not used.

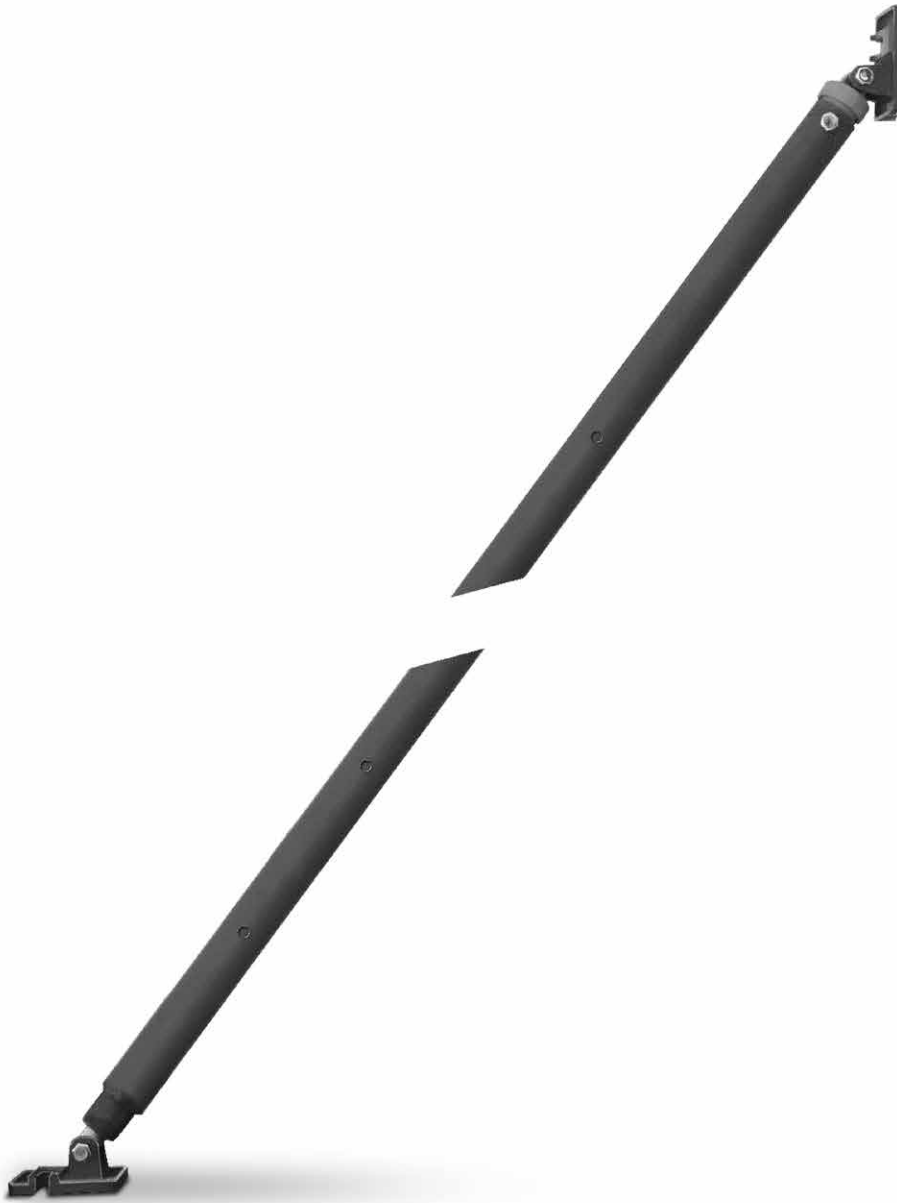

Accubrace[®] Total Bracing System



Accubrace is a total bracing system of Braces and Helical Ground Anchors engineered for unsurpassed speed and efficiency for tilt-up or precast applications. Installed by Dayton Superior professionals, this system provides an affordable, engineered solution.

Braces

A high-capacity brace designed to allow increased brace spacing for temporary stabilization of concrete wall panels.

Helical Ground Anchors

The Helical Ground Anchor (HGA) is part of a total bracing system designed for rapid installation and the ability to immediately load the helical ground anchor for unsurpassed speed and efficiency on any tilt-up or precast project.

HGA Extension

Certain sites where the foundation soils are lower strength may require the use of an HGA Extension. This shaft is the same section (1½" square bar) but is 4' in length and has a 10" helical plate set at 10" from the top of the extension.

Transition Brace Connector

The Transition Brace Connector connects the brace to the HGA. It leads to quicker installation and better alignment of the brace center-line to the HGA center-line.

Advantages:

- Reduces the number of braces needed by up to 60% to provide accelerated construction
- Engineered bracing system with documented load capacity
- Dayton Superior offers Professional Engineer review and stamp services
- Bracing on the outside of wall avoids structural steel erection
- Bracing on the inside of wall without a slab avoids holes in slab and/or vapor barrier
- Integrated in-line connection to the brace with the HGA and Transition Brace Connector
- Rapid, all-weather installation
- Recipient of the 2007 Robert Aiken Innovation Award sponsored by the TCA.
- Removable and reusable



**Contact Customer Service for rental information.
Available exclusively through Dayton Superior Tilt-Up Dealers.**

Accubrace Components

Braces



Brace	New Name	Outside Dimensions	Standard Brace Length	Brace Length Min.	Brace Length Max	Ultimate Load	Brace Weight*
B21F	B21R23S	4.0"	21'	21'-0"	23'-3"	23,250 lb**	230 lb
B27BF	B27R36S	5.0"	27'	25'-7"	27'-3"	36,000 lb**	350 lb
B32F	B32R24S	5.0"	32'	30'-9"	33'-3"	24,375 lb**	405 lb
B33F	B33R22S	5.0"	33'	31'-9"	34'-3"	22,500 lb	410 lb

NOTES: * Does not include weight of connectors.
 ** Ultimate Load based on adequate brace to HGA connection.



Accubrace Components

Brace Accessories



Description	SWL Tension	Length
Standard HGA (1½" Square Bar with 10" Helical Plates)	12,000 lb	7'-2"
Standard HGA Extension* (1½" Square Bar with 10" Helical Plate)	15,000 lb	4'-0"

* NOTE: When an extension is used, the working load of the HGA increases to 15,000lb for the installed torque of 2,200 ft/lb.



Standard Transition Brace Connector



T24 Adjustable Transition Brace Connector



T13 Coil-Anchor with Tang



Two-Hole Cast Wall Plate



Standard Wall and Floor Plate Bracket

Product Code	Description
139722	Standard Transition Brace Connector
146284	T24 Adjustable Transitions Brace Connector
121954	Two-Hole Cast Wall Plate
122514	Standard Wall and Floor Plate Bracket
49206 and 123045	T13 Coil-Anchor with Tang

* NOTE: When an extension is used, the working load of the HGA increases to 15,000lb for the installed torque of 2,200 ft/lb.

Overlap Multiplier for Bolts

Panel Thickness	Single T6S Ultimate Load	Double T6 Ultimate Load
5	12200	24000
5.5	14080	27724
6	16000	31200
6.5	18100	34762
7	20200	38054
7.5	22400	41402
8	24700	44752

For connection to slab, overall size must be appropriate for brace load and approved by a Professional Engineer.

Cast-In-Place Brace Anchor Loading

When using Dayton Superior T14 Tilt-Up Pie Braces the maximum brace load and ultimate load per brace anchor that can be safely transferred to T6A, T5A or T4 Brace Anchors is as follows:

Insert Type	Insert Depth	Panel Thickness	Ultimate Load (lbs)		Torque Per Anchor	
			Tension	Shear	Minimum	Maximum
T5A	3"	4"	7,794	10,998	80 ft lbs	115 ft lbs
T5A Heavy	5.25"	6"	18,044	22,532	100 ft lbs	140 ft lbs

Insert Type	Panel Thickness	Ultimate Load		Torque Per Anchor	
		Tension (lbs)	Shear (lbs)	Minimum	Maximum
T6A or T4	5"	12,560	9,840	100 ft lbs	140 ft lbs
T6A or T4	7.25"	17,960	19,280	100 ft lbs	140 ft lbs
T6S	5"	12,560	9,840	100 ft lbs	140 ft lbs
T6S	6"	17,400	14,400	100 ft lbs	140 ft lbs
T6S	7"	22,720	19,280	100 ft lbs	140 ft lbs
T6S	7.5"	25,560	22,030	100 ft lbs	140 ft lbs
T6S	8"	28,520	24,930	100 ft lbs	140 ft lbs

Ultimate Loads are based on 2,500 psi concrete

Maximum Ultimate Load is 20,000 lbs for T6A and 36,000 lbs for T6S

Corner or edge distances less than 1.5 times the embedment depth will proportionally reduce these ACI318, App. D Concrete limited capacities

Dayton Superior specifies the use of T4, T5A, T6A cast-in-place brace anchors or the T13 Coil-Anchor drill-in brace anchor ONLY. Dayton Superior does not specify or approve any other type of cast-in-place or drill-in anchor for the bracing of tilt-up wall panels. If any other type of brace anchor is used, the contractor does so at his own risk and assumes the risk of all serious personal injury, death or property damage which may result. By using such unspecified and unapproved brace anchor, the contractor agrees to indemnify and hold Dayton Superior harmless against all damages and losses that may occur.

When two braces per panel are required, the normal brace insert location for solid panels is .1 to .2 of panel width, minimum of 12", inward from panel side. Contact Dayton Superior for recommendations on panels requiring 3 braces or more, on panels with openings or for other unusual conditions.

Note: Notify Dayton Superior Technical Services if slab thickness is less than 5" thick. Brace design must be changed for thinner slabs.

Formliners

When it is time to choose concrete formliners, make your first choice Dayton Superior. For stock or custom orders, we have you covered.

Easy to install and easy to strip, Dayton Superior/Symons Formliners come in more than 100 contemporary designs and are available in Single Use and Medium Reuse materials. Repeat patterns eliminate seam lines.

Best of all, our formliners are labor-saving and money-saving, and they provide esthetics to your precast project.

Note: For more information on formliners, contact your Customer Service representative at 800-745-3700, or visit the Dayton Superior site at www.daytonsuperior.com.

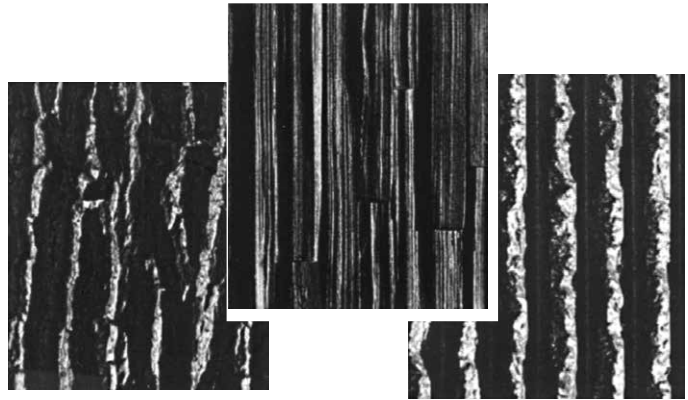

Vinyltite™ Trapezoidal Interlocking Formliners

For sharp-edged trapezoidal textures, choose Vinyltite formliners. The use of our Vinyltite formliner eliminates the costly labor involved in wood construction. You get continuous uniform texture reproduction pour after pour. Vinyltite is impervious to moisture and it won't swell, bulge or distort design integrity.

Vinyltite is easy to use with superior results. Vinyltite pre-drilled nailing strip lets you attach the formliner to the concrete slab or form without splitting or tearing. No more unsightly nail head impressions, and less sacking and patching costs. Interlocking joints ensure proper alignment and prevent concrete leakage. Connect the pieces to form large panel sections with no seam lines.

Wide ranges of widths and lengths. Lightweight, easy to handle and made of rigid HIPS or ABS plastic, Vinyltite comes in Single Use, Medium Use, or Heavy Reuse materials. Profiles are available in 6 inches to 18 inches wide, extruded to specified lengths up to 45'-0" for clean installation every time.

Thermoform™ Vacuum-Formed Formliners

Thermoform Concrete formliners are rigid plastic liners that are used to achieve detailed patterns and textured concrete surfaces for precast architectural concrete. You may select from a variety of patterns, or custom order to fit your needs – at only a nominal additional cost. All patterns are available in three different ranges: Single Use, Medium Reuse and High Reuse.

The Single Use, made from styrene, is ideal where the formliner will be used only once. The Medium Reuse, made from ABS materials, can be used up to 10 times. The High Reuse can be used up to 20 times under most conditions.

The vacuum-forming technology used in this product line allows virtually unlimited texturing opportunities, offering the most flexibility in custom designed patterns. This low cost reproduction process allows you to add exceptional economic options to the design integrity of your precast concrete projects. Due to the stretching of the plastic sheet material that occurs during the reshaping of the thermoforming process, some patterns with a high degree of texture or relief should not be produced in the thinner, single-use material. Normally supplied in 4' x 10' sheets.



FORM RELEASE AGENTS

OIL BASED

Clean Strip™ Ultra J3

Form Release

Clean Strip Ultra J3 is a premium, low odor, ready-to-use, low V.O.C. chemically reactive form release ideal for architectural and precast concrete and for general forming applications. Clean Strip Ultra J3 works to ensure clean, positive release of plywood, fiberglass, aluminum, steel and other concrete forming materials. Clean Strip Ultra J3 prolongs the life of plywood forms, and acts to reduce rusting of steel forms. Properly applied, Clean Strip Ultra J3 is non-staining, reduces the number of surface air voids (bugholes) and will not interfere with the adhesion of subsequent coatings.

Clean Strip™ J1A

Form Release

Clean Strip J1A is a low V.O.C., ready-to-use, petroleum based, chemically reactive concrete form release that effectively prevents bonding of concrete to forms and formliners.

Clean Strip™ J100 VOC

Form Release

Clean Strip J100 VOC is a V.O.C. compliant in all areas of the U.S., ready-to-use, petroleum based, chemically reactive concrete form release that effectively prevents bonding of concrete to forms and formliners. Regular use of Clean Strip J100 VOC will increase the life of all forms. Clean Strip J100 is compliant with all US VOC regulations for Concrete Form Release agents including Federal EPA, OTC, LADCO, SCAQMD & CARB.

Magic Kote®

Form Release

Magic Kote is a low V.O.C., ready-to-use, petroleum based, chemically neutral, diesel free concrete form release. Magic Kote is water insoluble and contains no waxes. Magic Kote effectively prevents bonding of concrete to forms and formliners. Regular use of Magic Kote will increase the life of all forms.

WATER BASED

Clean Strip™ J1EF

Earth Friendly® Form Release

Clean Strip J1EF is an economical low V.O.C., concrete form release agent. Clean Strip J1EF works to ensure clean, positive release on plywood, fiberglass, aluminum, steel, urethane and other concrete forming materials and formliners. This product acts as a barrier to the adhesion of concrete while minimizing surface dusting. Properly applied, Clean Strip J1EF will not stain concrete or interfere with the adhesion of coatings. Clean Strip J1EF is compliant with all US VOC regulations for Concrete Form Release agents including Federal EPA, OTC, LADCO, SCAQMD & CARB.

CURING COMPOUNDS

RESIN BASED

Clear Resin Cure J11W

Clear Resin Cure J11W is an all resin, dissipating water-based curing compound. Ready to use on freshly placed concrete surfaces. Complies with ASTM C-309.



BOND BREAKERS FOR CONCRETE-TO-CONCRETE RELEASE

WATER BASED

Sure Lift™ J6WB

Water-Based Bond Breaker

Sure Lift J6WB is a liquid, V.O.C. compliant, waterbased, reactive and membrane forming bond breaker for use in precast construction. Sure Lift J6WB is a special formula of polymers and propriety ingredients designed to provide clean, easy lifting of precast members.

SOLVENT BASED

Sure Lift™ with Dye J6D

Bond Breaker

Sure Lift with Dye J6D is a reactive and membrane forming bond breaker for use in tilt wall construction. Sure Lift with Dye J6D is a special formula of polymers and propriety ingredients designed to provide clean, easy lifting of precast members. Sure Lift with Dye J6D has a fugitive dye for ease of visual inspection during application and is also available without the dye upon special request.

EVAPORATION REDUCERS

AquaFilm™ Concentrate J74

Evaporation Retardant

AquaFilm Concentrate J74 is a proprietary emulsion of unique organic compounds designed to minimize moisture loss from fresh concrete. AquaFilm Concentrate J74 is economical as a concentrate and is diluted with potable water at a 9 to 1 ratio. As a water based polymer, AquaFilm Concentrate J74 is V.O.C. compliant and contains a blue fugitive dye for ease of visual inspection during application.

AquaFilm™ J74RTU

Evaporation Retardant

AquaFilm J74RTU is a ready-to-use proprietary emulsion of unique organic compounds designed to minimize moisture loss from fresh concrete. As a water based polymer, it is V.O.C. compliant. AquaFilm J74RTU contains a yellow fugitive dye.



EPOXY CONSTRUCTION ADHESIVES

ANCHORING GEL / PASTE

All Weather J51AW

Epoxy Gel Anchor

All Weather J51 AW is a two component 100% solid, moisture tolerant, all weather epoxy acrylate hybrid anchoring gel that meets ASTM C 881 specification requirements. All Weather J51 AW is formulated to set up at room temperatures and down to temperatures

Sure Anchor™ J50

Epoxy Gel Anchor

Sure Anchor J50 is a two component, 100% solids, moisture tolerant, high modulus epoxy gel adhesive that meets ASTM C-881 and AASHTO M-235.

Sure Anchor™ I J51

Epoxy Gel Anchor

Sure Anchor I J51 is two component, moisture tolerant, 100% solids, high modulus, rapid setting epoxy gel adhesive that meets ASTM C-881 and AASHTO M-235.

MEDIUM VISCOSITY

Sure Bond™ J58

Epoxy Adhesive

Sure Bond J58 is a 100% solids, two component, high modulus, medium viscosity, moisture tolerant structural epoxy adhesive that meets the requirements of ASTM C-881 and AASHTO M-235.

Sure Bond™ J58 LPL

Epoxy Adhesive

Sure Bond J58 LPL is a 100% solids, two component, high modulus, medium viscosity, moisture tolerant, long open time structural epoxy adhesive meeting the requirements of ASTM C-881 and AASHTO M-235.

LATEX BONDING AGENTS / ADMIXTURES

Acrylic Bonding Agent J40

Bonding Agent

A ready-to-use, non-reemulsifiable acrylic admixture and bonding agent designed to improve the adhesion and durability of concrete, masonry, terrazzo and portland cement-sand mixes to horizontal and vertical concrete and other surfaces.

PVA Bonding Agent J41

Bonding Agent

PVA Bonding Agent J41 is a concentrated reemulsifiable/rewettable polyvinyl acetate (PVA) emulsion for use as a bonding agent for application on concrete, cement board or masonry prior to installing patches, mortars, stucco and plaster.

NON-SHRINK GROUTS

CEMENT BASED GROUTS

1107 Advantage Grout™

Cement Based Grout

1107 Advantage Grout is a non-shrink, non-corrosive, non-metallic cementitious grout. 1107 Advantage Grout is designed to provide a controlled, positive expansion to ensure an excellent bearing area. 1107 Advantage Grout can be mixed from a fluid to a stiff plastic consistency.

Dri Pak Precast Grout

Cement Based Grout

Dri Pak Precast Grout is a non-shrink, non-corrosive, non-metallic cementitious grout. Dri Pak Precast Grout is designed to provide a controlled, positive expansion to ensure an excellent bearing area. Dri Pak Precast Grout can be mixed from a stiff to a flowable consistency.

Sleeve-Lock® Grout

Non-Shrink Grout

Sleeve-Lock Grout is a specially formulated cement based, non-metallic, non-shrink grout designed for the grouting of the Dayton Superior D410 Sleeve Lock® Grout Sleeve. The grout, used in conjunction with the sleeve, makes up a unique fully integrated system from Dayton Superior Corporation.

GENERAL USE REPAIR MORTARS



Polyfast™ FS

Repair Mortar

Polyfast FS is a shrinkage compensated, high strength mortar containing portland cement, special polymers and additives to provide an outstanding strength gain along with a fast set. Polyfast FS is a single component trowelable material formulated for vertical, overhead and horizontal repairs.

Recrete™ 5 Minute

Repair Mortar

Recrete 5 Minute is a general purpose cement based concrete repair and patching material. Recrete 5 Minute is specially formulated to provide a very fast setting repair mortar with excellent workability. Recrete 5 Minute can be used for repair and patching of vertical, overhead and horizontal areas subject to light traffic both interior and exterior.

Recrete™ 20 Minute

Repair Mortar

Recrete 20 Minute is a general purpose cement based concrete repair and patching material. Recrete 20 Minute is specially formulated to provide a fast setting repair mortar with excellent workability. Recrete 20 Minute can be used for repair and patching of vertical, overhead and horizontal areas subject to light traffic both interior and exterior.

Recrete™ Light 20 Minute

Repair Mortar

Recrete Light 20 Minute is a general purpose cement based concrete repair and patching material that dries to a light gray color. Recrete Light 20 Minute is specially formulated to provide a fast setting repair mortar with excellent workability. Recrete Light 20 Minute can be used for repair and patching of vertical, overhead and horizontal areas subject to light traffic both interior and exterior.

Anchor All

Anchoring Cement

A fast-setting, non-shrink anchoring cement with controlled expansion. Pourable and fast setting, Anchor All provides a durable high strength anchor for interior and exterior applications.

Waterstop™

Hydraulic Cement Repair Mortar

Waterstop is a non-corrosive, non-rusting, extremely fast setting hydraulic cement compound for plugging and stopping active water leaks in concrete structures or masonry surfaces. When mixed with water to a thick consistency and hand formed into a plug, it will stop active leaks even under water.

Dayton Superior Chemicals Dedicated Support

Dayton Superior quality construction chemicals are backed by experts in the construction chemicals field. They are dedicated to timely assistance in the selection and application of any Dayton Superior chemical product.

Customer service can be obtained from any Dayton Superior Service Center. For in depth product information such as Technical Data Sheets, specifications, Safety Data Sheets, visit the Dayton Superior web site at www.daytonsuperior.com.

Dayton Superior has experience, dedication, commitment and a comprehensive line of quality chemicals for the precast concrete industry. These necessary ingredients make Dayton Superior a valued partner to the precast/prestressed producer in their efforts to meet the inherent demands of the precast/ prestressed concrete industry.

Call 866-329-8724 for technical support, or for the contact information of your local Dayton Superior salesperson.

Rustications, Chamfers and Covers

Rustications, chamfers and cover products manufactured by Victory Bear provide innovative solutions to the designer and the contractor. These products provide significant labor savings in the installation of the rustications and chamfers along with eliminating much of the building finish problems which occur with wood products. And now these products can be found at a Dayton Superior distribution center near you.

SLAB SAVER

2' PVC Edge pieces installed in the bottom of wall panels used to protect floors during panel erection, eliminating damage to the floor slab during panel erection.

RUSTICATION

3/4" x 45 degree PVC rustication in widths of 2.25", 2.5", 3.5", 5.5", 8.0" and 11.5". These have the patented Flex Edge Seal, insuring a tight joint with the concrete slab and these utilize the Victory Bear Base Clip for easy installation. 1/2" x 60 degree low profile rustication also available.

SNAP RUSTICATION

3/4" Triangular PVC rustication which opens to allow easy installation and then snaps shut to prevent concrete seepage.

BULKHEAD

3/4" PVC bulkhead chamfer providing chamfer on both sides of the bulkhead. This product is used with both 3/4" plywood and 2x materials. It features both the patented Flex Edge Seal and utilizes the Base Clip to secure the product to the floor slab.

BULLNOSE

PVC Single Bullnose chamfers provide the radius edges when the designer desires a different effect from the traditional triangular building edges.

RADIUS CORNER

6" PVC Radius Corner provides a distinct radius at a fraction of the cost.

CHAMFERS

3/4" x 45 degree PVC chamfers in both single and double chamfer versions. This product utilizes the patented Flex Edge Seal and is attached to the floor slab with adhesives or traditional nails or screws.

CHAMFERS – LOW PROFILE

1/2" x 60 degree PVC chamfers in both single and double chamfer versions. This product utilizes the patented Flex Edge Seal and is attached to the floor slab with adhesives or traditional nails or screws.

DRIP EDGE CHAMFER

Use 3/4" x 45° PVC drip edge chamfer for use where doors, windows, dock doors and archways require both a chamfer and drip edge. This product utilizes the patented Flex Edge Seal and is attached to the floor slab with adhesives or traditional nails or screws.

RECESSED WINDOW SYSTEM

A unique utilization of several of the above products with a recessed window chamfer to add a classic detail for doors and windows in the concrete wall panels.

JOINT COVER

PVC Joint Covers provide the building owner an attractive cover for the joints inside of the building. Joint Covers will fit into panel joints between 1/4" and 1" gaps.

SAW CUT COVER

PVC Saw Cut Cover temporarily seals the floor slab joints with a unique low profile design

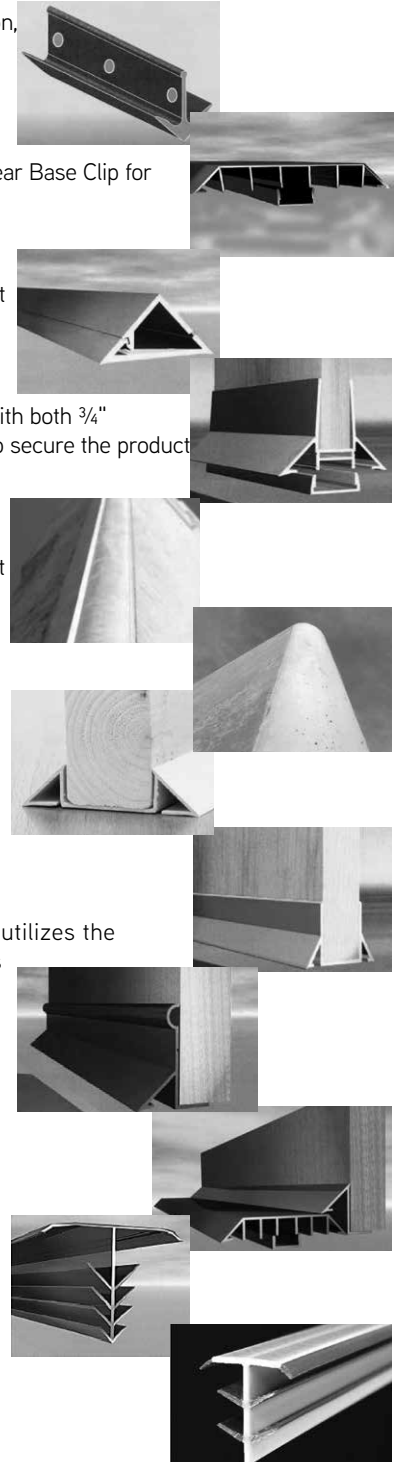

Aztec® PLW – EZ Lok Wheel™

Made from engineered composite resins, the E-Z Lok Wheel was designed for use in situations where a lightweight wheel is not sufficient to maintain proper location of the reinforcement. Once attached, this wheel will stay in place.

The unique symmetrical design maintains a consistent cover, regardless of the rebar size. With a wider hub, the E-Z Lok Wheel will not rack or fall off. The E-Z Lok Wheel offers flexibility and strength with multiple hub diameters for rebar sizes from 3/8" (No. 3) to 3/4" (No. 6) and is furnished in a variety of clearances.

It is suitable for use with larger diameters of welded wire fabric. The wheel will not change shape and will always provide uniform concrete cover. The E-Z Lok Wheel is perfect for any vertical application where concrete cover must be maintained and is the ultimate side form spacer when strength counts.

Note: Concrete cover is defined as the distance from where the reinforcement sits in the hub of the wheel to the outside of the wheel (where it contacts the form).

The E-Z Lok Wheel meets all requirements and qualifies as a CRSI Class 1 Bar Support. Available in the following cover heights: 1-1/2", 2-1/2" and 3". Sold in full cartons only.

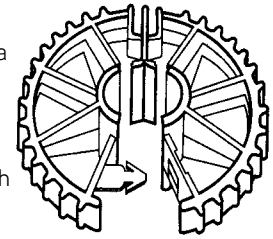

PIW – EZ Lok Wheel

To Order:

Specify: (1) quantity, (2) name, (3) cover height.

Example:

2 cartons, E-Z Lok Wheels, 1-1/2" cover height.

Aztec® PSW – Space Wheel™

The Space Wheel is excellent for use in wall, beam and column applications. It is made from composite resins, allowing the cardboard forming to roll easily over the reinforcement without damaging the face of the form, while still maintaining proper alignment.

Minimum form contact provides for excellent concrete finish without the rust marks or blemishes typical to other methods of spacing reinforcement. Designed to fit on a wide range of bar and wire mesh sizes assuring accurate placement, the Space Wheel is the perfect light duty side-form spacer.

Note: Concrete cover is defined as the distance from where the reinforcement sits in the hub of the wheel to the outside of the wheel (where it contacts the form).

The Space Wheel meets all requirements and qualifies as a CRSI Class 1 Bar Support. Available in cover heights from 3/8" to 3". Sold in full cartons only.

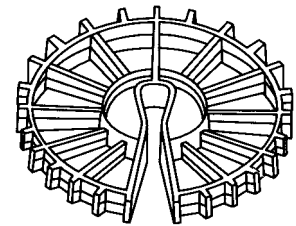

PSW – Space Wheel

Aztec® Bar Chair

Bar Chairs are used to support widely spaced, light steel in slab and deck construction. Each bar chair provides two cover heights that are clearly marked for field identification. Available in 3/4" to 2-1/2" cover heights and sold in full cartons only.

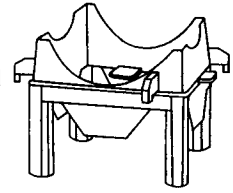

BPC Bar Chair

To Order:

Specify: (1) quantity, (2) name, (3) Product Code, (4) cover height.

Example:

2 cartons (900), 121288, Bar Chairs, 1-3/4" to 2" cover.

Aztec® Tower High Chair

Tower High Chairs are strong, preassembled supports for heavy applications. The design features staple-down feet, quick-tie hooks and two service heights. The two service heights allow reduced inventory and save warehouse space. Tower High Chairs are well suited for applications where multiple layers of steel are required. Chairs are available in cover heights from 2-3/4" to 10" and sold in full cartons only.

An optional Sand Plate (sold separately) is available for use on grade.

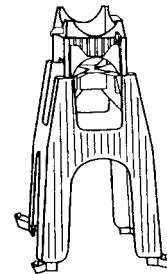

PTC Tower High Chair

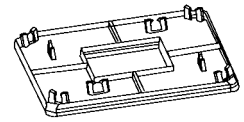

PTSCB Tower Chair Sand Plate

To Order:

Specify: (1) quantity, (2) name, (3) Product Code, (4) cover height.

Example:

2 cartons (300), 121295, Tower High Chairs, 6" cover.

Aztec® E-Z Chair®

E-Z Chairs are designed for superior strength and stability. They are well suited for tilt-up, precast and poured-in-place slab applications. They are available in 3/4" to 6" cover heights for rebar sizes up to #11. E-Z Chairs are sold in full cartons only.

An Optional Sand Plate is available for use on grade or in sandwich panel applications.

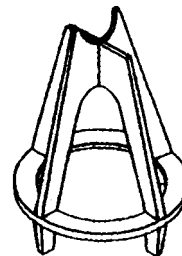

PEZ E-Z Chair

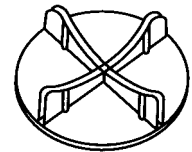

PSP Sand Plate

To Order:

Specify: (1) quantity, (2) name, (3) Product Code, (4) cover height.

Example:

4 cartons (700), 121271, E-Z Chairs, 4" cover.

Aztec® Castle Chair™

Castle Chairs are uniquely designed with a wide base ring to provide stability on poorly compacted or expansive soils. Each Castle Chair offers two cover heights to allow for variation in grading. They are strong enough to carry the weight of ironworkers and concrete finishers, but will not damage moisture protection membranes. Castle Chairs are available in 1-1/2" to 4-1/4" cover heights and are sold in full cartons only.

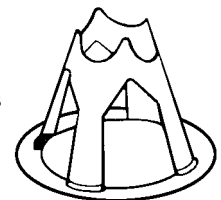

PCC Castle Chair

To Order:

Specify: (1) quantity, (2) name, (3) Product Code, (4) cover height.

Example:

2 cartons (700), 122837, Castle Chairs, 2-1/2" to 2-3/4" cover.

Aztec® X-Chair

X-Chairs are light weight, inexpensive chairs used for supporting rebar and wire mesh in horizontal applications. The X-Chair's novel design produces a very strong support with minimal surface contact. X-Chairs are available in 1/2" to 2" cover heights and are sold in full cartons only.

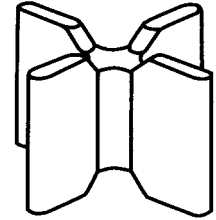

PXC X-Chair

To Order:

Specify: (1) quantity, (2) name, (3) cover height.

Example:

1 carton (1100), 122834, X-Chairs, 2" cover.

Aztec® E-Z Lok™ Slab Bolster

E-Z Lok Slab Bolster provides a strong, stable support and spacer for rebar in slab or wall applications. The E-Z Lok Slab Bolster can be used in individual 32" sections or the sections can be snapped together to satisfy any job-required length. E-Z Lok Slab Bolster is available in 3/4" to 3" cover heights and is sold in full cartons only.

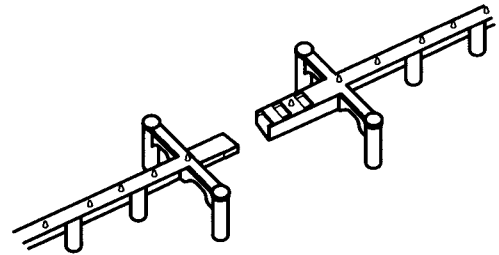

PSB E-Z LOK Slab Bolster

To Order:

Specify: (1) quantity, (2) name, (3) cover height.

Example:

2 cartons (300), 78066, E-Z LOK Slab Bolster, 2" cover.

Aztec® PSBU Strongback SBU™

PSBU supports top layer in Double Mat application, rebar or wire mesh, slabs, heavy duty on-grade, corrugated decking, side-form spacer-below-grade applications only, precast. Cover heights from 1" to 3-1/4" (1/4" increments).

- Designed for use with epoxy-coated/FRP/stainless steel/galvanized rebar
- Intended for use in corrosive environments
- Spans corrugations in elevated deck applications
- Suitable for use on vapor barriers or insulating foam
- No overlap required
- Manufactured in 30" lengths in standard boxes
- Special packaging available in 5' or 10' sections, bundled and palletized
- Strong as metal SBU

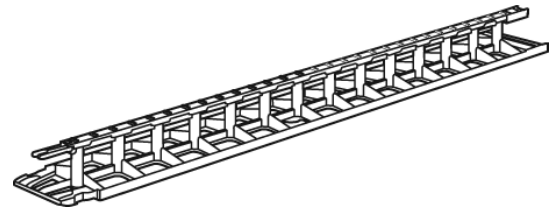

PSBU StrongBack SBU

To Order:

Specify: (1) quantity, (2) name, (3) name.

Example:

20 Boxes, 2-1/2" Cover Panel Pads.

Panel Pads

Panel Pads were created especially for use in the precast industry for stacking. When placed on top of the precast concrete elements, the Panel Pads will support the weight of additional elements without damage to either element. The unique bubble design allows the precast materials to cure uniformly. Panel Pads are manufactured to snap in half. The 2-1/2" x 5-1/2" pads are spaced around the precast unit.

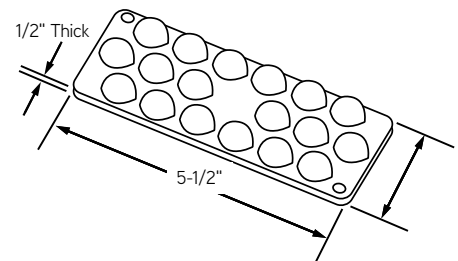

PPP - Panel Pads

To Order:

Specify: (1) quantity, (2) name.

Example:

200, Panel Pads.

Slab Bolster

Dayton Superior Slab Bolster is used to support lower slab steel from the slab form. Legs are spaced on 5" centers. Available in 3/4" to 3" heights in 5" lengths and in bright basic, galvanized, plastic protected or stainless steel protected.

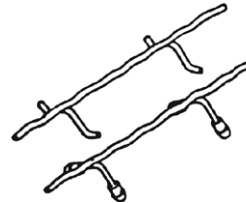

Slab Bolster

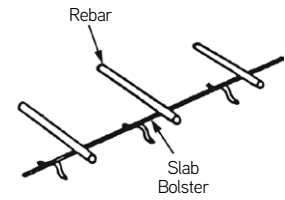

Beam Bolster

Dayton Superior Beam Bolster is used to support lower beam steel from the soffit form. Legs are spaced on 2-1/2" centers. Available in 1-1/2" to 5" heights in 5" lengths. Manufactured in bright basic, galvanized, plastic protected or stainless steel protected.

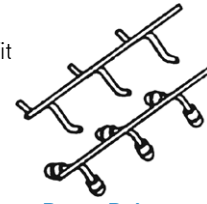

Beam Bolster

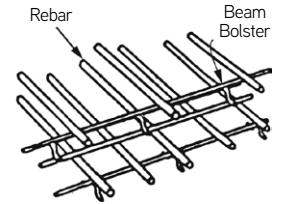

Continuous High Chair

Dayton Superior Continuous High Chair provides support for upper slab steel, eliminating the need for carrier bars. Fabricated in 2" to 15" heights, in 5" lengths with legs spaced on 7-1/2" centers. Available in bright basic, plastic protected, galvanized and stainless steel protected.

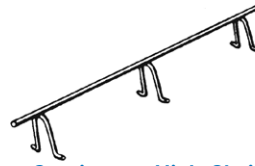

Continuous High Chair

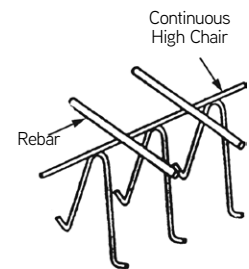

Individual High Chair

Dayton Superior Individual High Chair is used to support upper steel directly or by means of a carrier bar. Available in bright basic, plastic protected, and stainless steel protected.

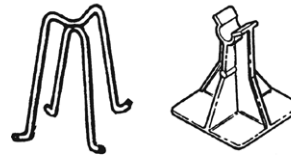

Individual High Chairs

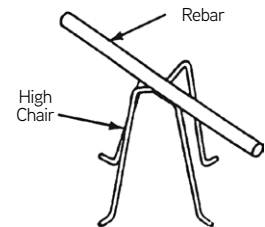

Bar Chair

Dayton Superior Bar Chair is used to support widely spaced light steel in slab construction. Available in 3/4" to 2" heights in bright basic, plastic protected, galvanized and stainless steel protected.



Bar Chair

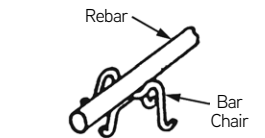

Joist Chair

Dayton Superior Joist Chair is used to support two bottom bars in the ribs of joist or grid type slabs. Available in 4", 5" and 6" overall widths; 1/4", 1" and 1-1/2" heights; and in bright basic, plastic protected, galvanized and stainless steel protected.



Joist Chair

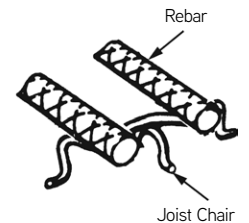

K50 Void Retention Insert

The Dayton Superior K50 Void Retention Insert's primary function is to conveniently position and firmly hold in place void tubes used in precast slabs, piles, box beams, etc. Use of the K50 inserts eliminates the possibility of the voids floating to the surface when concrete is placed in the forms. The K50 insert is injection-molded from nonreactive, noncorrosive thermoplastic and is designed to fit 10"- and 12"-diameter voids.

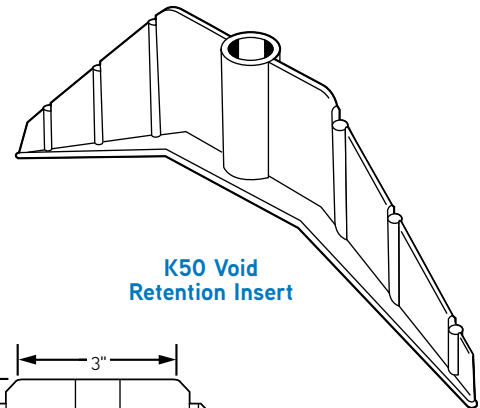
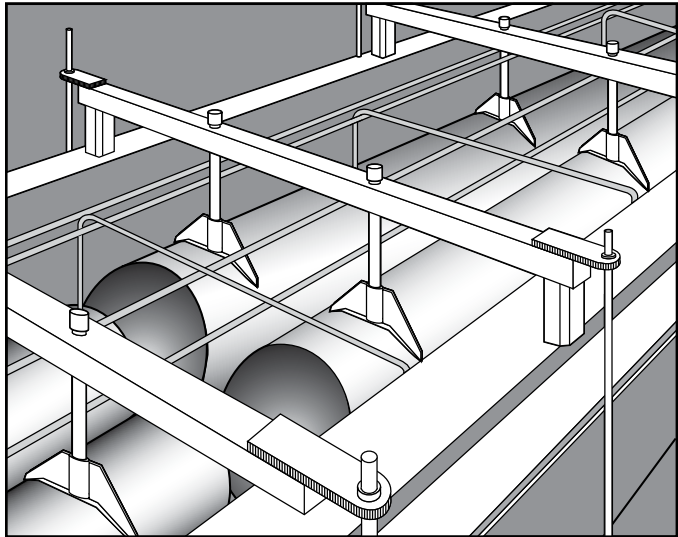

K50 Void Retention Insert

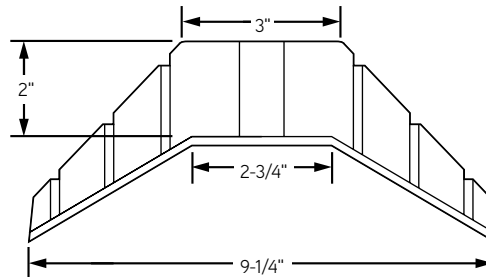

To Order:
Specify: (1) quantity, (2) name.

Example:
200, K50 Void Retention Inserts.

H13 Round Void Hold Down

The Dayton Superior Round Void Hold Down is a one piece unit that completely encompasses the round void tube and is attached to your form using a standard 3/4" coil bolt. This prevents movement in any direction of the void tube. Maintained in stock for 10" and 12" OD Diameter Void Tubes, other sizes available.



To Order:
Specify: (1) quantity, (2) dia of tube (4) plain or galvanized finish.

Example:
200, H13 12" Round Hold Down, Plain.

P80 Shim Strips

Dayton Superior P80 Shim Strips assure accurate placing and leveling of tilt-up panels and other architectural and structural components because they:

- are made in convenient thicknesses, lengths and widths allowing precise leveling and alignment.
- permit field changes in load bearing requirements with stock on hand.
- are less expensive and safer than steel. They have extreme stability and eliminate rust-stained concrete and spalling.
- are size scored for convenience of application. Prevent waste – material can be readily picked up and stored in the open for future use.
- will not fracture under load.
- are available from stock in thicknesses of 1/16", 1/8" and 1/4" and lengths of 3" and 4". The widths of 3" x 24" are scored every 3" and the widths of 4" x 24" are scored every 2". This allows for easy snap off as needed. Additional sizes available on request.
- are impervious to liquids, ground chemicals, alkalis and microorganisms. The continuing performance characteristics are stable and predictable.
- will not rust, rot or leach when exposed to wet surfaces and have no odor.
- arrive at the job site in precise thicknesses and lengths.
- eliminate the need for saws, hand tools or cutters. A definite saving in time, labor and money is realized. The strips are easily applied and lie flat.
- decrease damage potential to the adjacent concrete components. Point projection of aggregate is absorbed without fracture or effect on the load-bearing characteristics.

Engineering Data: The pertinent physical properties of Dayton Superior plastic shims are presented as follows:

- Compressive strength of 8,000 to 9,000 psi with no fracture, even at 26,000 psi.
- Classed as slow-burning with no toxic fumes.
- Negligible cold flow characteristics; i.e., less than 1% at 1,000 psi and 73°F. for 10,000 hours.
- Coefficient of linear expansion is 3 to 5 x 10⁻⁵ inches/inch/°C

To Order:

Specify: (1) quantity, (2) name, (3) length.

Example:

300, P80 Shim Strips, 1/4" x 4".

P81 Shimpak

Dayton Superior shimming material is an engineered multipolymer plastic specifically formulated for use by the construction industry.

This material provides an optimum combination of physical properties for a shim in applications where high compressive strength and load bearing are important. It facilitates the placement of tilt-up structural, and other architectural, members.

- These pre-assembled packages of heavy duty shims are designed for large precast units.
- Shimpaks are very advantageous in precise placing and leveling of large panels.
- Their use eliminates time consuming correction of elastomeric drift and makes alignment safer and easier.
- Popular sizes are 4" x 6" and 4" x 4" packs which are 1-1/16" thick. Shimpaks are made up of shims in the following thickness sequence: one 1/16", three 1/4" and two 1/8". Tilt-up panels can be levelled within 1/16" by removing or adding one or more elements.
- Shimpaks are held together with a resilient band for easy removal or addition of elements.
- Alternate sizes available on request.

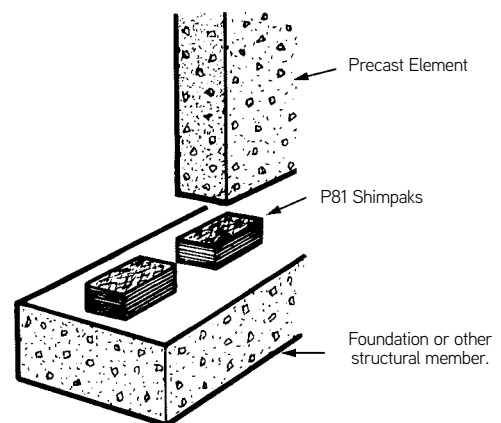

To Order:

Specify: (1) quantity, (2) name, (3) size.

Example:

200 packs, P81 Shimpaks, 4" x 6".

P82 Bearing Strips

- Designed for use with prestressed concrete plank between the plank and any surface, such as poured or precast concrete, steel or masonry.
- Absorb projecting aggregate stress preventing plank or sill damage without effect on the load bearing characteristics.
- Allow faster erection because of easier positioning.
- Nonslip surface ensures positive placement.
- Permit thermal motion and point rotation without an elastomeric layer.
- Test data available on request.

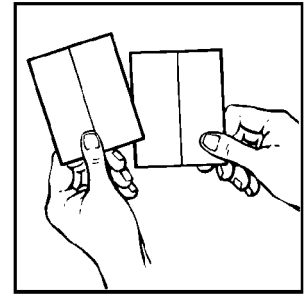
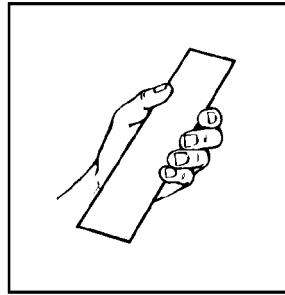

P82 Bearing Strips

Available in full cartons only. Each carton holds 300 2" x 48" strips.

Thicknesses of 1/8" and 1/4" in stock. Lengths of 48" in stock. Widths of 24", scored at 2" intervals for easy snap off and flexibility in use. Alternate sizes or scorings available on request.

P83 Horseshoe Spacers

- No staining, no rust, no corrosion, even with aluminum.
- Less expensive than steel—no plating required.
- Lightweight and precise—easy to handle and transport.
- Cut to size or prescored for easy on-site snap-off.

Available with holes, other slot sizes or different width, length or thickness on special order. Minimum order 100 pcs. of each thickness and size.

P83 Horseshoe Spacer Selection Table

Width	Length	Thickness	Slot Size
2"	3"	1/16", 1/8" or 1/4"	13/16" x 2-7/16"
3"	4"	1/16", 1/8" or 1/4"	13/16" x 2-15/16"

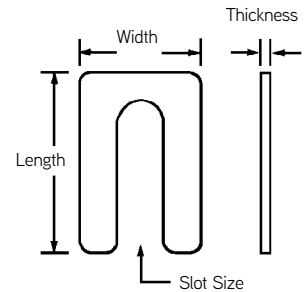
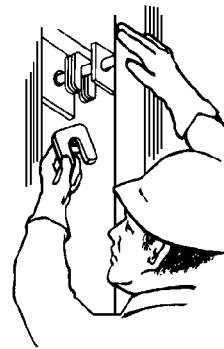

P83 Horseshoe Spacer

To Order:

Specify: (1) quantity, (2) name, (3) size.

Example:

2 cartons, P82 Bearing Strips, 1/4" x 48".

P84 Korolath Core Plugs

- Core plugs designed for manufacturers of prestressed hollow core plugs
- Lightweight, easy-to-insert, block off grout flow
- Exclusive "wall" taper design of plastic plugs assures tight fit
- Plug numbers refer to the diameter of the core holes, not the thickness of the plank

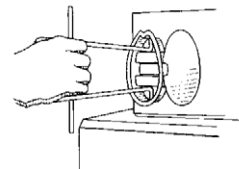
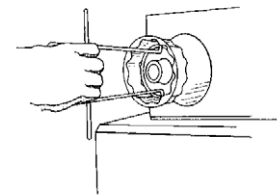

P84 Korolath Plugs

To Order:

Specify: (1) quantity, (2) name, (3) size.

Example:

2 cartons, P84 Core Plugs, No. 600.

Number	Diameter	Plugs/Carton
400	4"	1,000
600	6"	2,000
800	8"	1,000

F67, F68, and F69 Ceiling Hangers

F67 Ceiling Hanger

The Dayton Superior F67 Ceiling Hanger is designed for Flexicore deck slabs. Two sizes of ceiling hangers accommodate all five of the deck slabs. The 13" ceiling hanger fits the 10" and 12" deck slabs. The F67 hanger is placed between the slabs before keyways are grouted and topping placed.

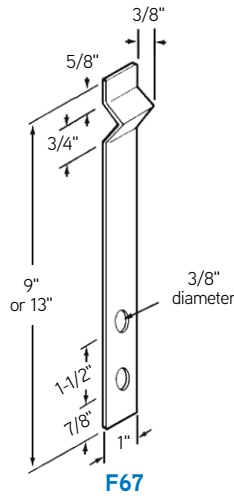

F68 Ceiling Hanger

The Dayton Superior F68 Ceiling Hanger is commonly used with double tees. The hanger is placed between the tees and used to hang ceilings, utilities, etc. The wide "T" of the hanger provides a large bearing area. 6" length is standard; other lengths are available on request.

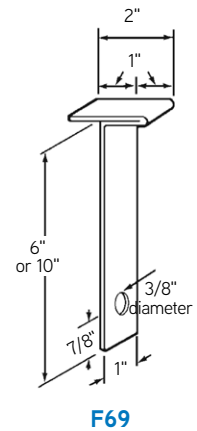
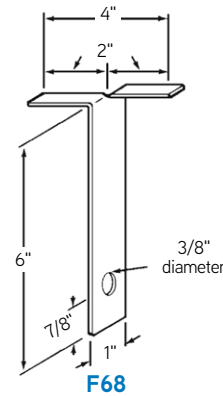

F69 Ceiling Hanger

The Dayton Superior F69 Ceiling Hanger is normally used between hollow core slab members to support suspended ceilings or utilities. Standard lengths are 6" and 10". Other lengths are available on request.

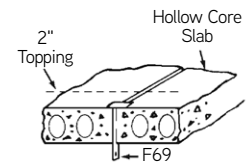
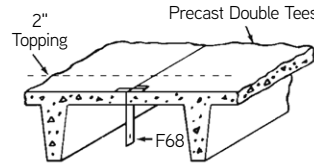
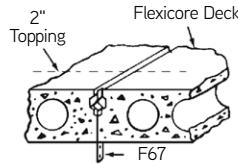

Ceiling hangers can be placed where required but are commonly spaced at 2 ft. intervals throughout the beam or slab length to provide for future hanger requirements. All hangers are made from galvanized stock.

Gauge	Type	Safe Working Load with Keyway Grouted and 2" Topping	Type	Safe Working Load with 2" Topping
16	F67	200 lbs.	F68, F69	400 lbs.
12	F67	400 lbs.	F68, F69	600 lbs.

Note: Hangers must have minimum of 2" topping slab in place and properly cured to adequately develop safe working load. With properly applied topping, approximate safety factor is 3 to 1.

To Order:

Specify: (1) quantity, (2) name, (3) gauge, (4) length.

Example:

1200 pcs., F68 Ceiling Hangers, 12 gauge, 6" long, P80 Shim Strips, 1/4" x 4".

F75 Marble Facing Anchor

The Dayton Superior F75 Marble Facing Anchor is a special stainless steel anchor used for anchoring marble, slate, thin limestone, etc., to precast work. The hooks are placed into predrilled holes in the marble and poured in with the concrete. Other sizes are available on special order.

To Order:

Specify: (1) quantity, (2) name.

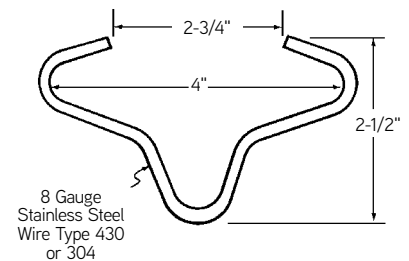

Cushion-Lock® Reglet Type B4

- PVC Construction
- No Reaction with Concrete
- No Caulking — now or ever
- 100% Leakproof
- No Exposed Metal Nails
- 10 ft. Lengths

The advanced design of this reglet offers a number of exclusive features, yet the in-place cost is actually lower than that of conventional reglets. The completely enclosed design of the B4 Reglet prevents any concrete from entering during pouring operation. Just prior to the installation of the counter-flashing, the integral protective strip is pulled off, exposing a clean recess ready to receive the counterflashing... and no caulking is needed as the snap-in and lock-in patented features of this reglet provides a 100% leakproof joint, yet future removal of the counterflashing for inspection or repair of roofing material is possible.

Recommended gauges for counterflashing are .020" to .032" maximum for aluminum or zinc; 26 to 24 gauge for steel; 16 or 20 oz. for copper. Fast and easy installation of counterflashing can be made under all weather conditions.

Each order for type B4 Reglet is supplied with sufficient connector plugs and installation instructions with a full-size template pattern for counterflashing.

Specifications

Specify Dayton Superior Type B4 Reglets and counterflashing in sheet metal section of specs. Sample specification: "Use Cushion-Lock Type B4 Reglet of PVC (polyvinyl chloride) plastic ASTM-D1784-81, Class 14333D, as manufactured by Dayton Superior Corporation.

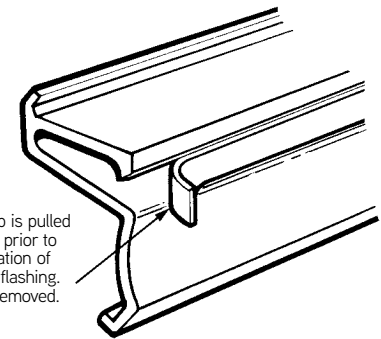

This Strip is pulled off just prior to installation of counterflashing. Easily removed.

Made of PVC (polyvinyl chloride) Plastic /060" thick, highest quality, ASTM-D1784-81 Class 14333D.

Connector Plugs

Connector Plugs, made from flexible PVC 3" long are supplied with B4 Reglet. They serve both to connect lengths of Reglet together, with adjoining openings perfectly aligned, as well as a plug to keep concrete from entering reglet at ends. Plugs may be easily removed to installation of counterflashing.

Installation

Counterflashing snaps and locks in position. Fastener is concealed and protected by counterflashing. DO NOT rivet or fasten ends of counterflashing together.

- Reglet is fastened to form at 12" O.C. with 6 or 8 penny double-headed nail.
- Concave design provides spring-like action to hold reglet tightly against form lumber, when nail is driven home.
- Reglet in position, after form is stripped, but prior to removal or integral protective strip.
- Lip acts as waterstop to prevent any possible water seepage behind reglet.

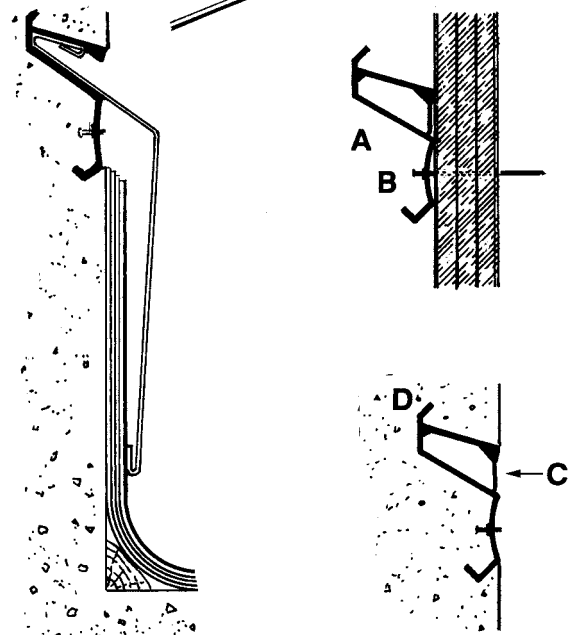
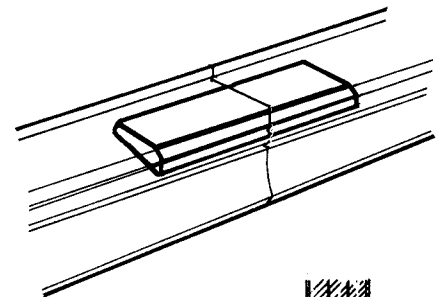

Insulation Fixings

Insulation Fixings are specifically designed for attaching foam insulation plates or foam panels in insulated wall applications. They are primarily used in marine dock construction. With its button head, wire mesh stays firmly in place over the foam panel. Available in 1" to 4" heights, 1,250 per carton.

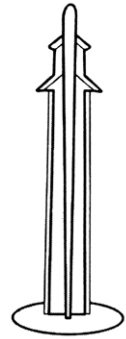

PFA Insulation Fixings

To Order:

Specify: (1) quantity, (2) name, (3) height.

Example:

2 cartons, insulation fixing, 4" height.

T68 ACA 1000™ Construction Spray Adhesive

T68 ACA 1000 is a specially designed, high strength, fast-tack contact spray adhesive to bond:

- Concrete
- Wood
- Metal
- MDF
- Plastic
- High Density Foam

Precast applications include:

- General Purpose
- Reveal/Rustication Strips
- Chamfer
- Blockouts
- Etc.

Shipped ground freight only – no air freight

Cal Voc Complaint Product available Rialto, CA only T68ACA1000C

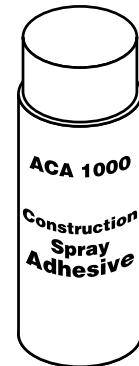

T68 ACA 1000 Construction Spray Adhesive

Sold only by the case:
12 cans per case.
One case minimum order.

Coverage Rate/Can
250 – 275 Sq. Ft.

To Order:

Specify: (1) quantity, (2) name.

Example:

3 cases, T68 ACA 1000 Construction Spray Adhesive.

P153 Magnetic Steel Chamfer and Reveal

Dayton Superior offers a variety of shapes of P153 Magnetic Steel Chamfers and Reveals. All offer unlimited reuses. The magnets are embedded in the steel and sealed with an epoxy material to insure no damage form concrete or maximum reuse.

Chamfers are typically 1/2" x 1/2", 3/4" x 3/4", and 1" x 1". Reveals can be made to fit most requirements. Many of these products are available in rigid plastic that offers a lower expense to the precaster but a smaller reuse factor. A flexible 3/4" x 3/4" rubber chamfer is available when radius precast shapes are encountered.

P154 On/Off Magnets, Cam Magnets, Button, Loaf Magnets and Accessories

Dayton Superior has a wide variety of magnets for use in precast forms.

ON/OFF MAGNETS

- Strong adhesion and shear capacity — 650# to 2500# adhesion
- Easy to turn on or off using 5/8" wrench with 90, 1/4 turn of end rotor
- Magnet attraction only on bottom of magnet
- Accepts standard op adapters or custom adapters provided by Dayton Superior



Custom On/Off Magnet

CAM MAGNETS

- Magnet is always on but easy to release from steel using built in cam release arm
- Magnet attraction along sides and bottom
- Available in different styles: Flat, Floating, Hole-Former, Notch
- Strong adhesion and shear capacity for small magnet, up to 1000# adhesion



Cam Magnet

BUTTON MAGNETS

- 1 Ton and 2.5 Ton Adhesion Capacities standard – other sizes available
- Easy push down button engages magnet & easy release from steel, using butt and release tool
- Attachment to forms brackets available
- Release tool available to reduce labor

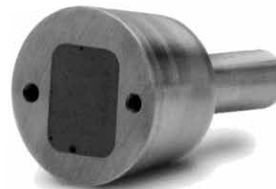

Custom Setting Plug

LOAF MAGNETS

- Standard sizes 3", 5", and 11" — custom sizes available
- Magnet is always on but can be released from steel using separate release arm
- Used in many applications including inside steel rails and securing wood forms in place
- Attachments to forms brackets available



Lift Insert Recess Member

MANHOLE STEP MAGNET AND RADIUS

- Size available for flat walls for 12", 16" and 24" steps
- Step pins available for all step manufacturer's products
- Separate tool used to remove step pin assembly from concrete
- Eliminates the need to drill holes in core for step pins

HOLE FORMERS AND DUCK MAGNETS

- Sizes available to fit into any size block-out, hole former or mandrel
- Different magnetic holding strengths available
- Eliminates the need to drill opening in concrete after it has been cast

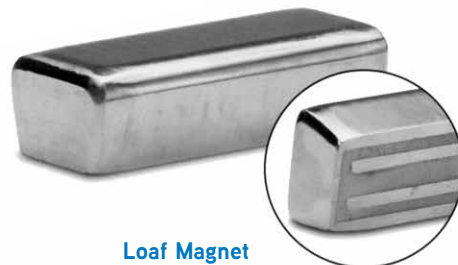

Loaf Magnet

BOOT GASKETS

- Utilizes magnet with Cam Release Arm
- Special fabricated attachment mechanisms available
- Available for any size boot gasket
- Available in hinged model for 90 degree attachment

PVC PIPE ATTACHMENT MAGNET

- Pipe Holding Magnets – Light Duty – Urethane
- Pipe Holding Magnets – Heavy Duty – Steel

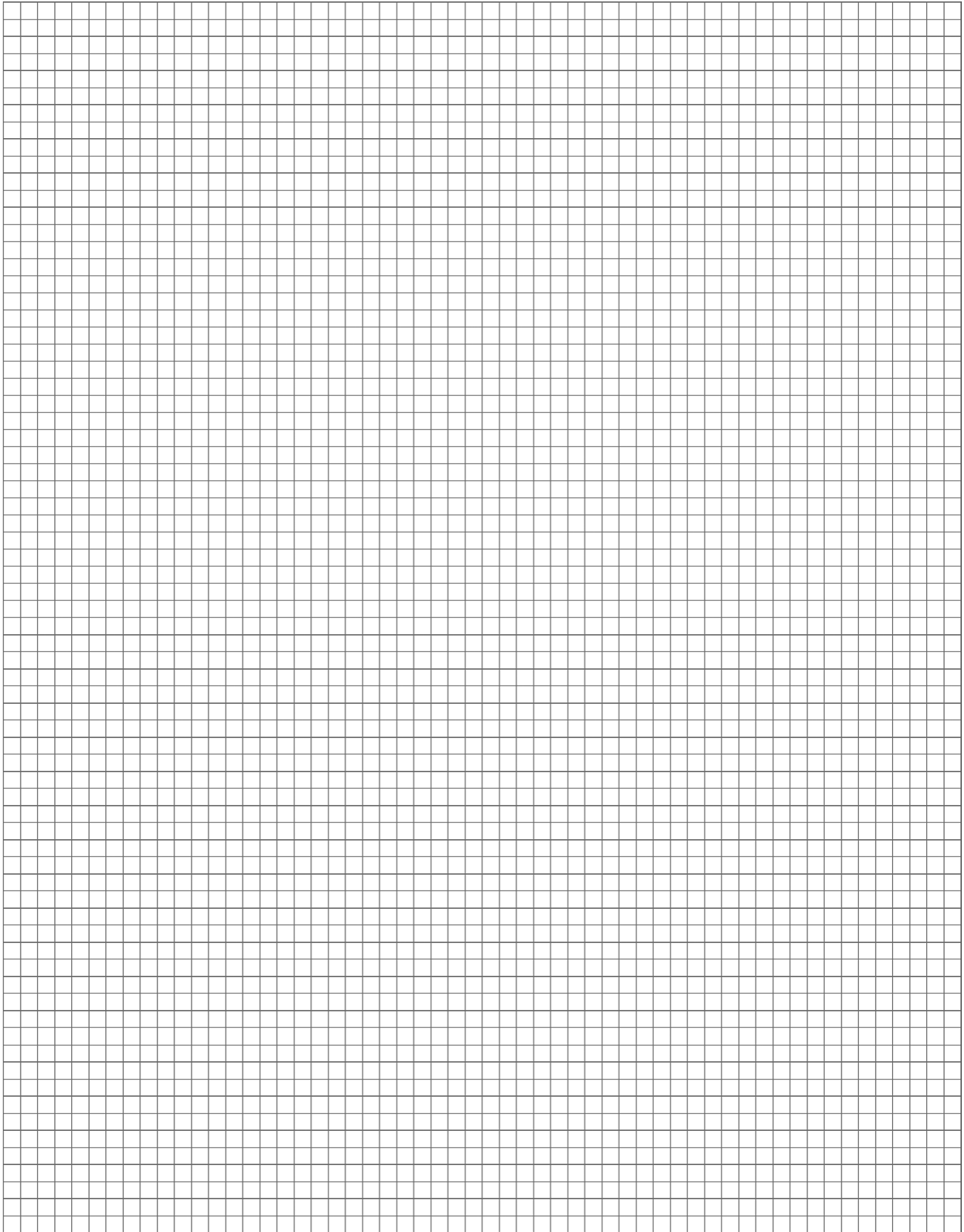

1107 Advantage Grout.....	146	Curing Compounds.....	145	Fleet-Lift Flat Foot Anchor.....	60
ACA 1000	158	Cushion-Lock Reglet	157	Fleet Lift Forged Erection Anchor	48
Accubrace Total Bracing System	140	D108A.....	111	Fleet-Lift Forged Erection Anchor	53
Acrylic Bonding Agent J40.....	146	D410	113	Fleet-Lift Forged Erection Anchor with Shear Plate and Secondary Shear Pin.....	50
Admixtures.....	146	D487.....	114	Fleet Lift Forged Erection Anchor with Sheer Plate ..	49
All Weather J51AW.....	146	D490.....	113	Fleet-Lift H-Anchor 2-Ton.....	59
Anchor All.....	147	D491	114	Fleet-Lift Holding Plate	64
AquaFilm Concentrate J74	146	D492.....	114	Fleet-Lift Holding Rod.....	64
AquaFilm J74RTU.....	146	D493.....	114	Fleet-Lift L-Anchor.....	58
Aztec Bar Chair	150	Delta Tie.....	127, 131	Fleet-Lift Magnetic Plate.....	73
Aztec Castle Chair	150	Disposable Setting Plugs.....	79	Fleet-Lift Plate Anchor	61
Aztec E-Z Chair	150	Double Flared Coil Loop Insert	86, 88	Fleet-Lift Reusable Recess Plug.....	64
Aztec E-Z Lok Slab Bolster.....	151	Double Flared Loop Insert	88	Fleet-Lift Ring Clutch	40
Aztec EZ Lok Wheel.....	149	Double Swivel Lifting Plate	98	Fleet-Lift S-Anchor 6-Ton.....	60
Aztec Space Wheel.....	149	Dowel Bar Splicer.....	115	Fleet-Lift Sandwich Panel Erection Anchor.....	54, 55
Aztec Strongback.....	151	Dri Pak Precast Grout.....	146	Fleet-Lift Sandwich Panel Erection Anchor with Shear Plate	54
Aztec Tower High Chair	150	Ductile Embed Insert.....	105	Fleet-Lift Sandwich Panel Reinforcing Bars	56
Aztec X-Chair.....	151	Dur-O-Web	124	Fleet-Lift Shear Bar	63
B183		Edge Lifting Plate.....	99	Fleet-Lift T-Anchor	58
B1A	137	End Pickup Inserts	94, 96	Fleet-Lift Tension Bar	63
B2	83	Epoxy Construction Adhesives.....	146	Fleet-Lift Two-Hole Anchor	61
B4	137, 157	Evaporation reducers.....	146	Fleet-Lift Two-Hole Erection Anchor	51
B5.....	137	Expanded Coil Ferrule Inserts	106	Fleet-Lift Two-Hole Erection Anchor with Shear Plate	51
B7.....	137	Expanded Coil Inserts	91	Fleet Patch.....	72
B8.....	137	Eye Bolt.....	89	Formliners	144
B9.....	137	Eye Nut.....	89	Form Release	145
B10.....	137	E-Z Chair.....	150	H13.....	153
B11.....	84, 137	E-Z Lok Slab Bolster.....	151	Hanger Hook	117
B12.....	84, 137	EZ Lok Wheel	149	Hanger Insert	117
B13.....	84	F5.....	101	Headed Dowel Bar Insert	111
B14.....	85, 137	F11.....	117	Heavy Coil Nut.....	84
B15.....	137	F12.....	117	Heavy Duty Long Pipe Brace.....	137
B16.....	86, 137	F42.....	101	Heavy Duty Regular Pipe Brace.....	137
B17.....	86	F43.....	102	Helical Ground Anchors.....	140
B18.....	87, 137	F44.....	103	HGA	140
B25.....	84	F45.....	103	HGA Extension.....	140
B33.....	88	F47.....	88	Horseshoe Spacers.....	155
Bar Chair.....	150, 152	F48.....	89	Individual High Chair	152
Bar Lock Coupler	116	F49.....	89	Insert Locator Plugs.....	98
Beam Bolster.....	152	F49A.....	89	Insulation Fixings.....	158
Bearing Strips	155	F50.....	104	J1A.....	145
Block Wall Lifting Anchor	76	F52.....	104	J1EF.....	145
Bond Breakers	145	F53.....	90	J3.....	145
Brace Length.....	137	F54.....	105	J6D.....	146
Braces.....	140	F56.....	91	J6WB.....	145
Brace Safe Working Loads.....	137	F57.....	106	J11W.....	145
Cap Plug.....	103	F58.....	91	J40	146
Cast-In-Place Brace Anchor Loading.....	143	F59.....	106	J41	146
Castle Chair	150	F60.....	91	J51	146
Ceiling Hangers.....	156	F61.....	106	J51AW.....	146
Chamfers.....	148	F62.....	107	J58.....	146
Clean Strip J1A.....	145	F63.....	92	J58 LPL	146
Clean Strip J1EF.....	145	F64.....	108	J74.....	146
Clean Strip J100 VOC.....	145	F65.....	92	J74RTU.....	146
Clean Strip Ultra J3.....	145	F67.....	156	J100 VOC.....	145
Clear Resin Cure J11W.....	145	F68.....	156	Joist Chair.....	152
Coil Bolt.....	85	F69.....	156	Jumbo Pipe Braces.....	137
Coil Nut.....	84	F72.....	109	K50	153
Coil Rod.....	84	F74.....	109	Korolath Core Plugs.....	155
Coil Ties Used as Inserts.....	83	F75.....	156	Latex Bonding Agents.....	146
Connecting Systems Nylon Threaded Inserts.....	110	Ferrule Loop Insert.....	108	Lifting Angle	95
Connector Plugs	157	Flared Thin Slab Coil Insert.....	92	Loop Ferrule Insert.....	101
Construction Spray Adhesive	158	Flared Thin Slab Ferrule Insert.....	107	Magic Kote	145
Continuous High Chair	152	Flat Washer.....	84	Magnetic OnePiece Swift Lift Recess.....	38
Corewall Edge and Corner Details.....	121	Fleet-Lift.....	39	Magnetic Steel Chamfer and Reveal.....	159
Corewall Generation III Insert	122	Fleet-Lift Cable Bail Ring Clutch.....	41	Magnets.....	159
Corewall Nut Type Slotted Insert	117, 118	Fleet-Lift Cast Steel Recess Plug.....	66	"M" Anchor Shear Connector.....	133
Corewall Slotted Insert II	120	Fleet-Lift Disposable Recess Plug.....	68	Marble Facing Anchor.....	156
Corewall Slotted Strap Anchor.....	119	Fleet-Lift Erection Anchor.....	42	Mounting Washers.....	83
Corewall Strap Anchor	119	Fleet-Lift Erection Anchor with 45° Head with Shear Plate	57	Non-Shrink Grouts	146
Corewall Strap Type Slotted Insert	117, 119	Fleet-Lift Erection Anchor with Shear Plate.....	44		
Corewall Threaded Strap Anchor	119	Fleet-Lift Erection Anchor with Shear Plate and Shear Pin.....	46		
Countersunk Screw.....	37				

Nylon Threaded Inserts	110	P94H	59	Swift Lift Anchors for Edge Lifting	25
One Piece Magnetic Utility Anchor Recess	80	P94S	60	Swift Lift Eye Anchor	32
P1	93	P95F	60	Swift Lift Lifting Eye	19
P9	133	P95P	61	Swift Lift Magnetic Setting Plate	38
P12D	124	P96	61	Swift Lift Narrow Recess Plug	35
P12G	132	P98S	63	Swift Lift Plus Holding Plate	38
P21	90	P98T	63	Swift Lift Plus Holding Stud	37
P24	127	P99	64	Swift Lift Plus Recess Plug	36
P24XL	131	P99C	66	Swift Lift Plus Stud Plate	38
P25	95	P99D	68	Swift Lift Plus Threaded Plate	38
P30	117, 118	P99P	72	Swift Lift Plus Wing Nut	37
P31	117, 119	P100	64, 80	Swift Lift Round Recess Plug	35
P32	119	P100M	73	Swift Lift Rubber Ring	36
P33	119	P100MS	73	Swift Lift Setting Plate	37
P34	119	P101	64, 80	Swift Lift Shear Bar	26
P37	133	P104	38, 80	Swift Lift Smooth Wire Shear Bar	26
P38	120	P110	82	Swift Lift Steel Recess Plug	36
P39	122	P153	159	Swift Lift Stud	37
P50	17	P154	159	Swift Lift Tapped Plate	38
P51	19	Panel Pads	151	Swift Lift Tension Bar	33
P52	22, 25	PBC Tower Bar Chair	150	Swift Lift Throw-Away Recess Plug	34
P52W	25	PCC Castle Chair	150	Swift Lift Universal Lifting Eye	17
P53	32	PEZ E-Z Chair	150	Swift Lift Wing Nut	37
P54	34	Pipe Brace Extensions	136	Swivel Lifting Plate	98
P56	23, 35	Plain Ferrule	102	T1	93
P56PL	23, 36	Plastic Setting Bolt	95	T3	94
P56R	35	PLW	149	T3A	94
P57	36	Polyfast FS	147	T5A	143
P58	36	Precast Sandwich Panel Tie	133	T6A	143
P59	26	Prestress Strand Restraining Devices	135	T7S	95
P60	33	PSB E-Z LOK Slab Bolster	151	T7ST	95
P61	37	PSBU	151	T8	95
P62	37	PSBU StrongBack SBU	151	T10	96
P63	37	PSP Sand Plate	150	T11	96
P63PL	37	PSW	149	T12	98
P64	37	PTC Tower High Chair	150	T14	136
P64PL	37	PTSCB Tower Chair Sand Plate	150	T14 Brace Length and Ultimate Loads	137
P66	38	PVA Bonding Agent J41	146	T15	136
P66PL	38	PXC X-Chair	151	T21	98
P67PL	38	Recess Plugs	23	T26	98
P68PL	38	Recrete 5 Minute	147	T27	99
P69	38	Recrete 20 Minute	147	T68	158
P72	76	Recrete Light 20 Minute	147	T110	62
P73SL	77	Repair Mortars	147	Thermoform	144
P75	78	Rocket/Kohler Ferrule Insert	104	Thin Slab Coil Insert	90
P75C	78	Round Void Hold Down	153	Thin Slab Ferrule Insert	103, 104
P75H	78	Rustications	148	Thin Slab utility Anchor	77
P76	79, 81	Safety	1	Threaded Insert	101
P76C	79	Setting Screw	73	Threaded Plastic Plug	109
P76D	79	Shimpak	154	Threaded Setting Plug	109
P76M	80	Shim Strips	154	Tilt-Up Wall Braces	136
P80	154	Short Pipe Brace	137	Tower High Chair	150
P81	154	Single Flared Coil Loop Insert	87	Transition Brace Connector	140
P82	155	Single Pickup Insert	93	Type L Coil Insert	92
P83	155	Slab Bolster	151, 152	Utility Anchor	78
P84	155	Sleeve-Lock 3/4" SCH40 PVC	114	Utility Anchor and Double Tee Anchor Setting Plug	81
P90	110	Sleeve-Lock Form Plug	114	Utility Anchor Cover/Patch	79
P91NC	41	Sleeve-Lock Grout	113, 147	Utility Anchor Holding Plate	80
P91S	40	Sleeve-Lock Grout Sleeve	113	Utility Anchor Holding Rod	80
P92AH	57	Sleeve-Lock Port Plug	114	Utility Anchor Magnetic Setting Plate	80
P92DP	46	Sleeve-Lock Seal Plug	114	Utility Anchor Setting Plugs	79
P92FE	48	Space Wheel	149	Utility Anchor System	75
P92FEH	53	Straight Coil Loop Insert	86	Utility Anchor with Clip	78
P92FEW	49	Strongback SBU	151	Vynltime	144
P92FEWDP	50	Superior Lift System	62	Void Retention Insert	153
P92H	51	Sure Anchor I J51	146	Waterstop	147
P92HP	51	Sure Anchor J50	146	Welded Wire Girders	132
P92P	44	Sure Bond J58	146	Wire Rope Lifting System	82
P92S	54	Sure Bond J58 LPL	146	Wire Rope Loop	90
P92SF	55	Sure Lift J6WB	145	X-Chair	151
P92SP	54	Sure Lift with Dye J6D	146		
P92T	42, 56	Swift Lift	17		
P93	58	Swift Lift Anchor	22, 25		

	<p style="text-align: center;"> WARNING</p> <p style="text-align: center;">Improper Use of Concrete Accessories Can Cause Severe Injury or Death</p> <p>Read, understand and follow the information and instructions in this publication before using any of the Dayton Superior concrete accessories displayed herein. When in doubt about the proper use or installation of any Dayton Superior concrete accessory, immediately contact the nearest Dayton Superior Service Center or Technical Service Department for clarification. See back cover for your nearest location.</p>
---	--

Dayton Superior products are intended for use by trained, qualified and experienced workers only. Misuse or lack of supervision and/or inspection can contribute to serious accidents or deaths. Any application other than those shown in this publication should be carefully tested before use.

The user of Dayton Superior products must evaluate the product application, determine the safe working load and control all field conditions to prevent applications of loads in excess of a product's safe working load. Safety factors shown in this publication are approximate minimum values. The data used to develop safe working loads for products displayed in this publication are a combination of actual testing and/or other industry sources. Recommended safe working loads given for the products in this publication must never be exceeded.

Worn Working Parts

For safety, concrete accessories must be properly used and maintained. Concrete accessories shown in this publication may be subject to wear, overloading, corrosion, deformation, intentional alteration and other factors that may affect the device's performance. All reusable accessories must be inspected regularly by the user to determine if they may be used at the rated safe working load or should be removed from service. The frequency of inspections depends upon factors such as (but not limited to) the amount of use, period of service and environment. It is the responsibility of the user to schedule accessory hardware inspections for wear and remove the hardware from service when wear is noted.

Shop or Field Modification

Welding can compromise a product's safe working load value and cause hazardous situations. Knowledge of materials, heat treating and welding procedures is necessary for proper welding. Consult a local welding supply dealer for assistance in determining required welding procedures.

Since Dayton Superior cannot control workmanship or conditions in which modifications are done, Dayton Superior cannot be responsible for any product altered in the field.

Interchangeability

Many concrete accessory products that Dayton Superior manufactures are designed as part of a system. Dayton Superior strongly discourages efforts to interchange products supplied by other manufacturers with components supplied by Dayton Superior. When used properly, and in accordance with published instructions, Dayton Superior products have proven to be among the best designed and safest in the industry. Used improperly or with incompatible components supplied by other manufacturers, Dayton Superior products or systems may be rendered unsafe.

Installation

WARNING

1. Dayton Superior Corporation products shall be installed and used only as indicated on the Dayton Superior Corporation installation guidelines and training materials.
2. Dayton Superior Corporation products must never be used for a purpose other than the purpose for which they were designed or in a manner that exceeds specific load ratings.
3. All instructions are to be completely followed to ensure proper and safe installation and performance.
4. Any improper misuse, misapplication, installation, or other failure to follow Dayton Superior Corporation's instruction may cause product malfunction, property damage, serious bodily injury and death.

THE CUSTOMER IS RESPONSIBLE FOR THE FOLLOWING:

1. Conformance to all governing codes
2. Use of appropriate industry standard hardware
3. The integrity of structures to which the products are attached, including their capability to safely accept the loads imposed, as evaluated by a qualified engineer.

SAFETY INSTRUCTIONS:

All governing codes and regulations and those required by the job site must be observed. Always use appropriate safety equipment

Design Changes

Dayton Superior reserves the right to change product designs, rated loads and product dimensions at any time without prior notice.

Note: See Safety Notes and Safety Factor Information.



1125 Byers Road
Miamisburg, OH 45342
937-866-0711
888-977-9600

**PERFORM
WITH
PRECISION**

DS5
10/15

Copyright © 2015 Dayton Superior Corporation, All Rights Reserved.