

# Pipe & Manhole Handling

## Model MHL - Concrete Manhole Housing Lifter

**NEW**

**INSTOCK PROGRAM**



### PRODUCT FEATURES:

- Handle concrete pipe efficiently without damage to concrete seat.
- Legs can be quickly positioned to safely balance the load.
- 2 or 3 leg models available.
- Handles 4" – 6" concrete wall thickness.
- Requires constant tension to maintain positive load contact.
- Complies with ASME standards.

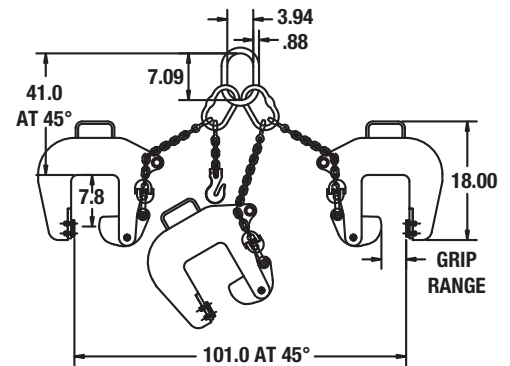
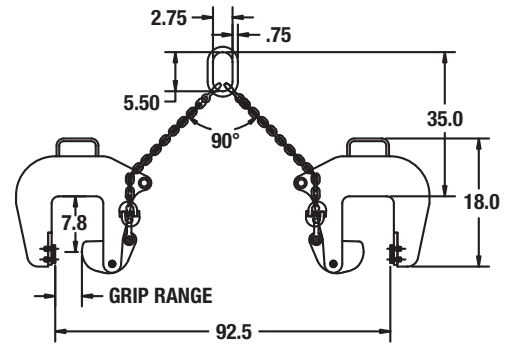

3-Leg Model

**NOTE:** Dimensions shown in inches.

### SPECIFICATIONS

Model Number	Grip Range Min-Max (in.)	Description	Maximum Diameter (in.)	Capacity (lbs.)	Weight (lbs.)
MHL-5-2/4	2 - 4	2-Leg Model - Two 42" Legs	92.5	10000	126
MHL-5-4/6	4 - 6				131
MHL-7.1/2-2/4	2 - 4	3-Leg Model - Two 42" Legs - One 72" Leg With Chain Shortener	101	15000	176
MHL-7.1/2-4/6	4 - 6				181
MHL-C-2/4	2 - 4	Clamp Only	-	5000	40
MHL-C-4/6	4 - 6				45

**NOTE:** Reverse cam action eliminates slippage tendency. Consult factory for other housing configurations.

## Operation

