

Clamps, Grabs & Tongs

CLAMPS,
GRABS &
TONGS

Model ST - Slab Tongs



IN-STOCK PROGRAM

3.25 Ton SHACKLE

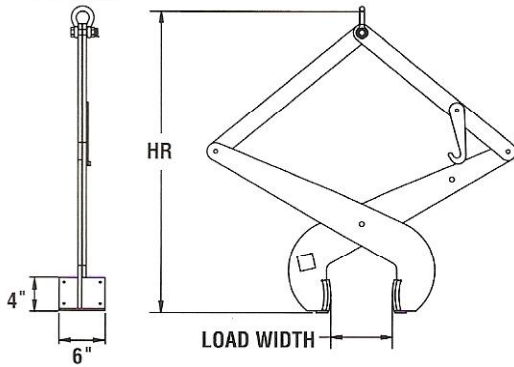

PRODUCT FEATURES:

- Designed for lifting dry slabs of concrete stone, or metal that must be protected from scratching or marring.
- Use in construction work to position slabs.
- The curved pads give proper contact for gripping smooth surfaces and handling a large range of sizes.
- Polyurethane gripping surfaces are standard.
- A manual latch is standard and locks the tong arms for easy placement on the load.
- Designed and manufactured to ASME standards.

SPECIFICATIONS

Model Number	Rated Capacity (lbs.)	Load Width (in.) Min. - Max.	HR (in.) Min. - Max.	Weight (lbs.)
71-0	1000	1 - 6	31.30 - 39.58	65
71-1	1000	6 - 10	35.06 - 43.00	75
71-2	1500	8 - 12	29.18 - 38.06	85
71-3	1500	10 - 14	31.43 - 42.00	145
71-4	1500	14 - 18	41.38 - 51.25	145
71-5	1500	18 - 22	48.90 - 60.00	150

Model CGCS-N - Grab With Polyurethane Pads



IN-STOCK PROGRAM

PRODUCT FEATURES:

- Designed for handling cured concrete products.
- Automatically adjust to the load size.
- Easy to release manual latch.
- Pivoting pads align with load surface for proper contact.
- Polyurethane pads grip surface without damage.

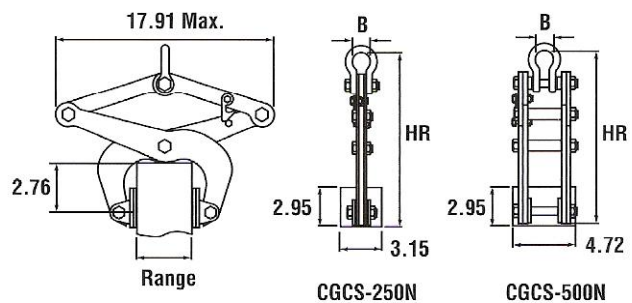

NOTE: Dimensions shown in inches.

SPECIFICATIONS

Model Number	Rated Cap. (lbs.)	Dimensions (inches)			Weight (lbs.)
		Clamping Range Min. - Max.	HR Min. - Max.	B	
CGCS-250N	551	1-3/16 - 5-1/2	11.22 - 16.93	1.38	16
CGCS-500N	1100	1-3/16 - 5-1/2	11.22 - 16.93	1.38	29