

Clamps, Grabs & Tongs

CLAMPS,
GRABS &
TONGS

Model AMCS - Non-Marring Adjustable Clamps

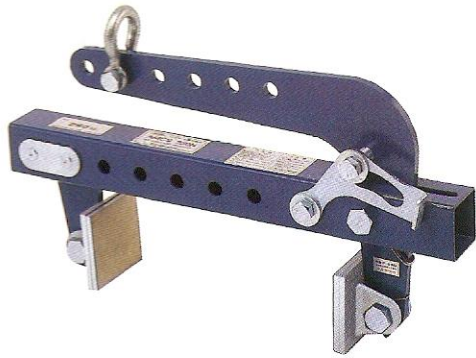

IN-STOCK PROGRAM

PRODUCT FEATURES:

- Designed for handling cured concrete products.
- Multiple adjusting ranges.
- Pivoting pads align with the load surface for proper contact.
- Adjustable lifting point to ensure a balanced lift.

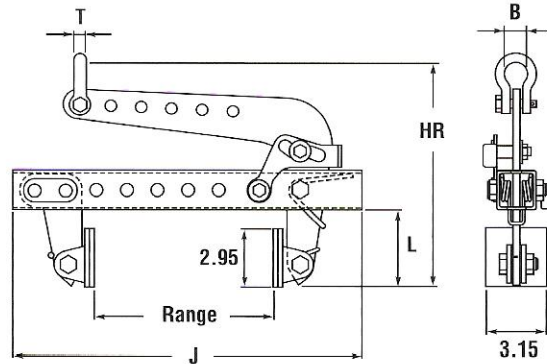

NOTE: Dimensions shown in inches.

SPECIFICATIONS

Model Number	Rated Cap. (lbs.)	Dimensions (inches)						Weight (lbs.)
		Range Min. - Max.	HR Min. - Max.	B	J	L	T	
AMCS-250N	551	3/8 - 9-7/16	10.63 - 16.54	1.18	18.11	3.94	0.47	12
AMCS-500N	1100	3/8 - 9-7/16	10.63 - 16.54	1.38	18.11	3.94	0.55	17

Model UGC - Handle Clamps

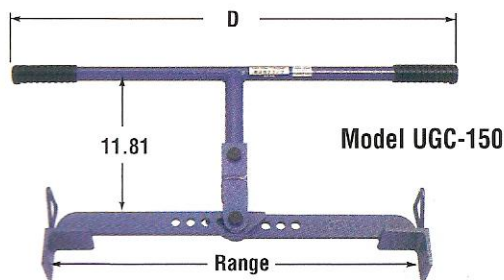

PRODUCT FEATURES:

- Designed for handling cured concrete products.
- Multiple adjusting ranges.
- Available with a carrying handle only (UGC-150) or carrying handle and lifting lugs.
- Machined pad surface grips the load.

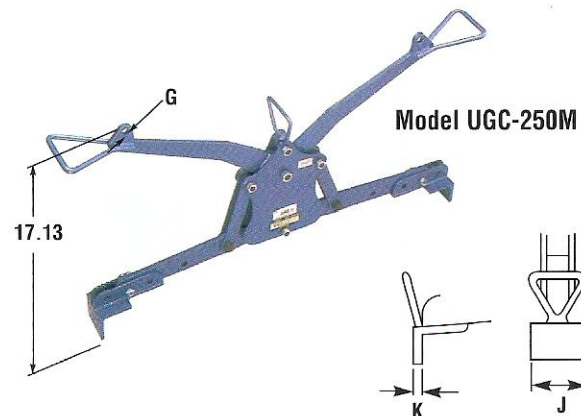

NOTE: Dimensions shown in inches.

SPECIFICATIONS

Model Number	Rated Cap. (lbs.)	Dimensions (inches)					Weight (lbs.)
		Range Min. - Max.	D	G (Dia.)	J	K	
UGC-150	330	15-23/32 - 23-19/32	31.89	-	2.95	0.35	12
UGCS-150M	330	15-23/32 - 23-19/32	24.65	0.79	2.95	0.35	18
UGC-250M	551	22-13/16 - 41-5/16	40.95	0.55	3.15	0.35	36

IN-STOCK PROGRAM